



Chipsmall Limited consists of a professional team with an average of over 10 year of expertise in the distribution of electronic components. Based in Hongkong, we have already established firm and mutual-benefit business relationships with customers from,Europe,America and south Asia,supplying obsolete and hard-to-find components to meet their specific needs.

With the principle of “Quality Parts,Customers Priority,Honest Operation,and Considerate Service”,our business mainly focus on the distribution of electronic components. Line cards we deal with include Microchip,ALPS,ROHM,Xilinx,Pulse,ON,Everlight and Freescale. Main products comprise IC,Modules,Potentiometer,IC Socket,Relay,Connector.Our parts cover such applications as commercial,industrial, and automotives areas.

We are looking forward to setting up business relationship with you and hope to provide you with the best service and solution. Let us make a better world for our industry!



Contact us

Tel: +86-755-8981 8866 Fax: +86-755-8427 6832

Email & Skype: info@chipsmall.com Web: www.chipsmall.com

Address: A1208, Overseas Decoration Building, #122 Zhenhua RD., Futian, Shenzhen, China





GS2986 Multi-Rate SDI Reclocker with Equalization & De-emphasis

Features

- SMPTE 424M, SMPTE 292M and SMPTE 259M-C compliant
- Supports DVB-ASI at 270Mb/s
- Single supply operation at 3.3V or 2.5V
- 180mW typical power consumption (213mW with RCO enabled) at 2.5V
- Input signal equalization and output-signal de-emphasis settings to compensate for board-trace dielectric losses
- 4:1 input multiplexer patented technology
- Choice of dual reclocked data outputs or one reclocked data output and one clock output
- Uses standard 27MHz crystal
- Cascadable crystal buffer supports multiple reclockers using a single crystal
- Differential inputs and outputs
 - ◆ support DC coupling to industry-standard differential logic
 - ◆ on-chip 100Ω differential data input/output termination
 - ◆ selectable 400mVppd or 800mVppd output swing on each output
 - ◆ seamless interface to other Gennum products
- 4 wire SPI host interface for device configuration and monitoring
- Standard logic control and status signal levels
- Auto and Manual modes for rate selection
- Standards indication in Auto mode
- Lock Detect Output
- Mute, Bypass and Autobypass functions
- SD/ $\overline{\text{HD}}$ indication output to control GS2978 or GS2988 dual slew-rate cable drivers
- Operating temperature range: -40°C to +85°C
- Small footprint QFN package (6mm x 6mm)
- Pb-free and RoHS compliant

Applications

- SMPTE 424M, SMPTE 292M and SMPTE 259M-C coaxial cable serial digital interfaces

Description

The GS2986 is a multi-rate serial digital reclocker designed to automatically recover the embedded clock from a digital video signal and retime the incoming video data. It will recover the embedded clock signal and retime the data from a SMPTE 424M, SMPTE 292M, or SMPTE 259M-C compliant digital video signal.

A serial host interface provides the ability to configure and monitor multiple GS2986 devices in a daisy-chain configuration.

Adjustable input trace equalization (EQ) for up to 40" of FR4 trace losses, and adjustable output de-emphasis (DE) for up to 20" of FR4 trace losses, can be configured via the host interface.

The GS2986 can operate in either auto or manual rate selection mode. In Auto mode, the device will automatically detect and lock onto incoming SMPTE SDI data signals at any supported rate. For single rate data systems, the GS2986 can be configured to operate in Manual mode. In both modes, the device requires only one external crystal to set the VCO frequency when not locked and provides adjustment free operation.

The GS2986 accepts industry-standard differential input levels including LVPECL and CML. The differential data and clock outputs feature selectable output swing via the host interface, ensuring compatibility with most industry-standard, terminated differential receivers.

The GS2986 features dual differential outputs. The second output can be configured to emit either the recovered clock signal or the re-timed video data. This output can also be disabled to save power.

In systems which require passing of non-SMPTE data rates, the GS2986 can be configured to either automatically or manually enter a bypass mode in order to pass the signal without reclocking.

The GS2986 is Pb-free, and the encapsulation compound does not contain halogenated flame retardant. This component and all homogeneous sub-components are RoHS compliant.

Contents

Features.....	1
Applications.....	1
Description.....	1
Revision History	2
1. Pin Out.....	5
1.1 Pin Assignment	5
1.2 Pin Descriptions	6
1.3 Default Start-up Settings	8
2. Electrical Characteristics	9
2.1 Absolute Maximum Ratings	9
2.2 DC Electrical Characteristics	9
2.3 AC Electrical Characteristics	10
3. Input/Output Circuits	13
4. Detailed Description.....	17
4.1 Serial Data Input	17
4.2 Modes of Operation	17
4.3 Input Trace Equalization	17
4.4 4:1 Input Mux	18
4.5 Crystal Buffer	19
4.6 LOS (Loss Of Signal) Detection	19
4.7 Serial Digital Reclocker	20
4.8 Lock Detection	20
4.8.1 Lock Detect and Asynchronous Lock	21
4.9 Serial Data Output	21
4.9.1 Output Signal Interface Levels.....	21
4.9.2 Adjustable Output Swing.....	21
4.9.3 Output De-emphasis	21
4.10 Automatic and Manual Data Rate Selection	22
4.11 SD/ $\overline{\text{HD}}$ Indication	23
4.12 Bypass Mode	23
4.13 DVB-ASI	24
4.14 Output Mute and Data/Clock Output Selection	24
4.15 Host Interface	24
4.15.1 Introduction.....	24
4.15.2 Legacy Mode & Start-up.....	25
4.15.3 Host Interface Mode & Start-up.....	25
4.15.4 Clock & Data Timing.....	25
4.15.5 Single Device Operation.....	25
4.15.6 Write Operation - Single Device.....	26
4.15.7 Read Operation - Single Device	27
4.15.8 Daisy Chain Operation.....	29
4.15.9 Read & Write Operation - Daisy Chained Devices	30
4.15.10 Writing to all Devices	30
4.15.11 Writing to a Single Device in the Chain	31

4.15.12 Reading from all Devices	31
4.15.13 Reading from a Single Device in the Chain.....	32
4.15.14 Host Register Map.....	33
4.16 Device Power-up	36
4.17 Standby	36
5. Typical Application Circuit	37
6. Package and Ordering Information.....	38
6.1 Package Dimensions	38
6.2 Recommended PCB Footprint	39
6.3 Packaging Data	39
6.4 Marking Diagram	40
6.5 Solder Reflow Profile	40
6.6 Ordering Information	41

1. Pin Out

1.1 Pin Assignment

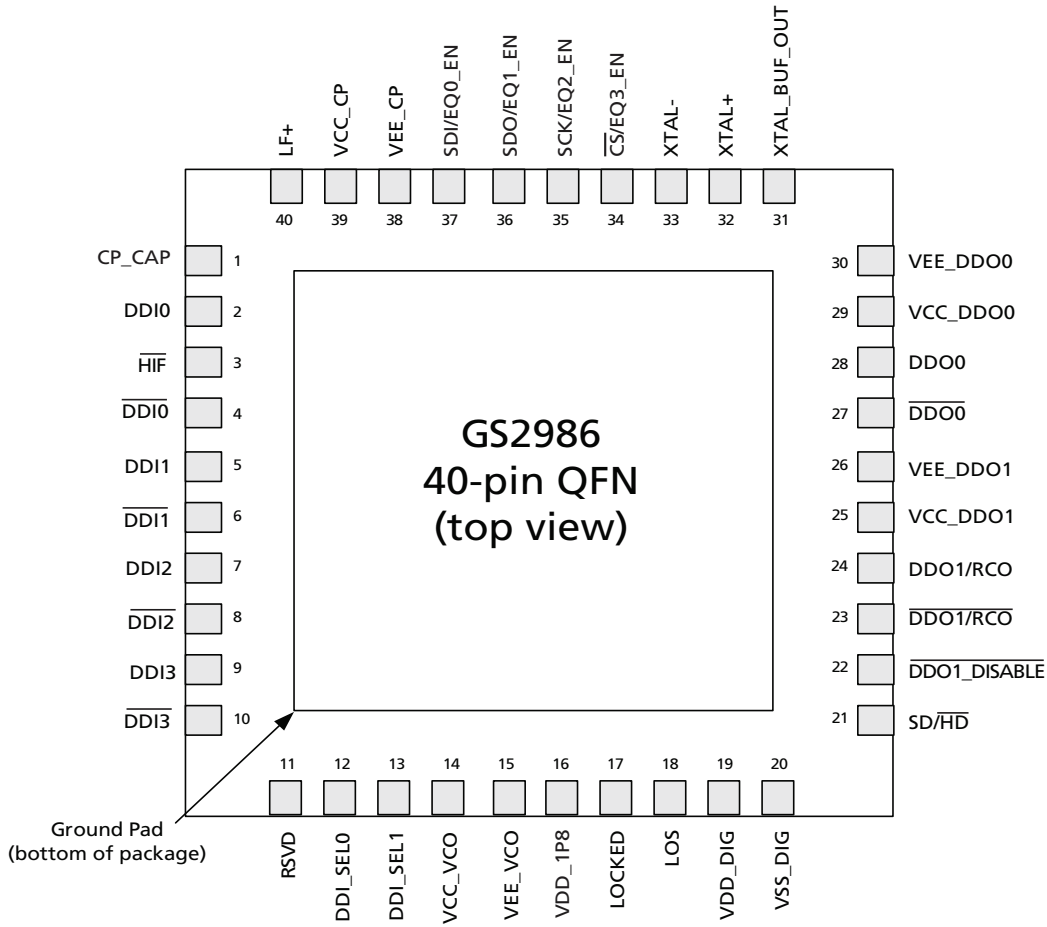

Figure 1-1: GS2986 Pin Out

1.2 Pin Descriptions

Table 1-1: GS2986 Pin Descriptions

Pin Number	Name	Type	Description
1	CP_CAP	Power	External capacitor for internal LDO regulator supplying the charge pump circuit.
2, 4	DDI0, $\overline{\text{DDI0}}$	Input	Serial Digital Differential Input 0.
3	HIF	Logic Input	Host interface selection pin. Active-low input. See Section 4.15.1 .
5, 6	DDI1, $\overline{\text{DDI1}}$	Input	Serial Digital Differential Input 1.
7, 8	DDI2, $\overline{\text{DDI2}}$	Input	Serial Digital Differential Input 2.
9, 10	DDI3, $\overline{\text{DDI3}}$	Input	Serial Digital Differential Input 3.
11	RSVD	Reserved	Reserved pin. Do not connect to this pin.
12, 13	DDI_SEL[0:1]	Logic Input	Selects one of four serial digital input signals for processing. See Section 4.4 .
14	VCC_VCO	Power	Most positive power supply connection for the internal VCO section. Connect to a 3.3V supply with a 422Ω resistor, or to a 2.5V supply with a 267Ω resistor.
15	VEE_VCO	Power	Most negative power supply connection for the internal VCO section. Connect to GND.
16	VDD_1P8	Power	External capacitor for internal 1.8V digital supply.
17	LOCKED	Output	Lock Detect status signal. HIGH when the PLL is locked.
18	LOS	Output	Loss Of Signal status. HIGH when the input signal is invalid.
19	VDD_DIG	Power	Most positive power supply connection for the digital core. Connect to 3.3V or 2.5V.
20	VSS_DIG	Power	Most negative power supply for the digital core. Connect to GND.
21	SD/ $\overline{\text{HD}}$	Output	This signal will be LOW for all rates other than 270Mb/s. This signal is HIGH for 270Mb/s.
22	$\overline{\text{DDO1_DISABLE}}$	Logic Input	Disables the DDO1/RCO and $\overline{\text{DDO1/RCO}}$ outputs when LOW. See Section 4.14 .
23, 24	$\overline{\text{DDO1/RCO}}$, DDO1/RCO	Output	Differential serial clock or data outputs.
25	VCC_DDO1	Power	Most positive power supply connection for the DDO1/ $\overline{\text{DDO1}}$ output driver. Connect to 3.3V or 2.5V.
26	VEE_DDO1	Power	Most negative power supply connection for the DDO1/ $\overline{\text{DDO1}}$ output driver. Connect to GND.
27, 28	$\overline{\text{DDO0}}$, DDO0	Output	Differential Serial Digital Outputs.

Table 1-1: GS2986 Pin Descriptions (Continued)

Pin Number	Name	Type	Description
29	VCC_DDO0	Power	Most positive power supply connection for the DDO0/ $\overline{\text{DDO0}}$ output driver. Connect to 3.3V or 2.5V.
30	VEE_DDO0	Power	Most negative power supply connection for the DDO0/ $\overline{\text{DDO0}}$ output driver. Connect to GND.
31	XTAL_BUF_OUT	Output	Buffered output of the reference oscillator.
32	XTAL+	Output	Reference crystal output.
33	XTAL-	Input	Reference crystal input.
34	$\overline{\text{CS}}$ /EQ3_EN	Input/Logic Input	In host mode ($\overline{\text{HIF}}$ set LOW): Chip select input for SPI serial host interface. Active-low input. In non-host mode ($\overline{\text{HIF}}$ set HIGH): Trace equalization on/off pin for Serial Digital Differential Input 3. Active-high input.
35	SCK/EQ2_EN	Input/Logic Input	In host mode ($\overline{\text{HIF}}$ set LOW): Burst-mode clock input for SPI serial host interface. In non-host mode ($\overline{\text{HIF}}$ set HIGH): Trace equalization on/off pin for Serial Digital Differential Input 2. Active-high input.
36	SDO/EQ1_EN	Input/Logic Input	In host mode ($\overline{\text{HIF}}$ set LOW): Serial digital data output for SPI serial host interface. Active-high output. In non-host mode ($\overline{\text{HIF}}$ set HIGH): Trace equalization on/off pin for Serial Digital Differential Input 1. Active-high input.
37	SDI/EQ0_EN	Input/Logic Input	In host mode ($\overline{\text{HIF}}$ set LOW): Serial digital data input for SPI serial host interface. Active-high input. In non-host mode ($\overline{\text{HIF}}$ set HIGH): Trace equalization on/off pin for Serial Digital Differential Input 0. Active-high input.
38	VEE_CP	Power	Most negative power supply connection for the internal charge pump. Connect to GND.
39	VCC_CP	Power	Most positive power supply connection for the internal charge pump. Connect to 3.3V or 2.5V
40	LF+	Passive	Loop Filter capacitor connection. (CLF = 47nF). Connect as shown in Typical Application Circuit on page 37 .
–	Center Pad	–	Ground pad on bottom of package. Connect to GND.

1.3 Default Start-up Settings

The GS2986 has some functions that are not accessible via direct pin control, and are only accessible through the host interface registers. These functions have an internal pull-up or pull-down resistor that sets the default logic level or start-up state, if it is not already set by a pin.

If the user wishes to override these logic levels, the associated bit should be programmed within the PIN_OR_1 register (pin override register) at address 0x0C. The logic values within the PIN_OR_1 register become active when the user sets the Pin Override Enable bit to HIGH within that same register.

Table 1-2 shows:

1. The default logic state set by the internal pull-up or pull-down resistors.
2. The default values within the Pin Override register upon reset.

More details are given in [Section 4.15](#).

Table 1-2: GS2986 Default Start-up Settings

Name	Description	Default State set by Internal Resistors	Default State within the Pin Override Register
BYPASS	Bypasses the reclocker stage when set HIGH.	0	0
AUTOBYPASS	When set HIGH, this bit automatically bypasses the reclocker stage when the PLL is not locked to a supported rate.	0	0
AUTO/ $\overline{\text{MAN}}$	When set HIGH, the standard is automatically detected from the input data rate.	1	0
SS0, SS1	When AUTO/ $\overline{\text{MAN}}$ is set HIGH, SS[1:0] are outputs displaying the data rate to which the PLL has locked. Therefore, the bits will not have a default start-up value.	None	0:0
KBB	Controls the loop bandwidth of the PLL.	Floating	Ground
$\overline{\text{DATA_MUTE}}$	Mutes the $\overline{\text{DDO0}}/\overline{\text{DDO0}}$ and $\overline{\text{DDO1}}/\overline{\text{DDO1}}$ (if data is selected) outputs when LOW.	1	0
$\overline{\text{DATA/CLOCK}}$	HIGH = DATA LOW = CLOCK	0	0
DE_EN	De-emphasis on/off pin for serial digital output. HIGH = de-emphasis on LOW = de-emphasis off	0	0

2. Electrical Characteristics

2.1 Absolute Maximum Ratings

Parameter	Value
Supply Voltage	-0.5 to +3.6V _{DC}
Input ESD Voltage	4kV
Storage Temperature Range	-50°C < T _A < 125°C
Operating Temperature Range	-40°C to 85°C
Input Voltage Range	-0.3 to (VCC + 0.3) V _{DC}
Solder Reflow Temperature	260°C

2.2 DC Electrical Characteristics

Table 2-1: DC Electrical Characteristics

Parameter	Symbol	Conditions	Min	Typ	Max	Units
Supply Voltage	VDD	3.3V	3.135	3.3	3.465	V
		2.5V	2.375	2.5	2.625	V
Power (DDO1/RCO disabled, minimum output swing)	P	VDD = 3.3V	–	250	325	mW
		VDD = 2.5V	–	180	235	mW
Power (DDO1/RCO enabled, minimum output swing)		VDD = 3.3V	–	290	390	mW
		VDD = 2.5V	–	210	275	mW
Power in Power-down mode		VDD = 3.3V	–	48	60	mW
		VDD = 2.5V	–	30	40	mW
Serial Input Termination	–	Differential	80	100	120	Ω
Serial Output Termination	–	Differential	80	100	120	Ω
Serial Input Common Mode Voltage	–	–	1.6	–	VDD	V
Serial Output Common Mode Voltage	–	–	–	VCC - (ΔVOD / 2)	–	V
VIL (2.5V operation)	–	VOUT ≤ VOL, max	-0.3	–	0.7	V
VIL (3.3V operation)	–	VOUT ≤ VOL, max	-0.3	–	0.8	V
VIH (2.5V operation)	–	VOUT ≥ VOH, min	1.7	–	VDD + 0.3	V
VIH (3.3V operation)	–	VOUT ≥ VOH, min	2	–	VDD + 0.3	V
IIN	–	VIN = 0V or VIN = VDD	–	+/-10	+/-20	μA

Table 2-1: DC Electrical Characteristics (Continued)

Parameter	Symbol	Conditions	Min	Typ	Max	Units
VOL (2.5V operation)	–	VDD = min, IOL = 100 μ A	–	–	0.2	V
VOL (3.3V operation)	–	VDD = min, IOL = 100 μ A	–	–	0.2	V
VOH (2.5V operation)	–	VDD = min, IOH = -100 μ A	2.1	–	–	V
VOH (3.3V operation)	–	VDD = min, IOH = -100 μ A	VDD -0.4	–	–	V
Hysteresis Voltage (SPI inputs)	–	2.5V operation	–	350	–	mV
NOTE: guaranteed by simulation.	–	3.3V operation	–	350	–	mV

2.3 AC Electrical Characteristics

Table 2-2: AC Electrical Characteristics

Parameter	Symbol	Conditions	Min	Typ	Max	Units	Notes
Serial Input Data Rate (for reclocking)	DR _{SDO}	–	0.27	–	2.97	Gb/s	–
Serial Input Data Rate (bypass)	–	–	DC	–	2.97	Gb/s	–
SPI Operating Speed	–	–	–	–	10	MHz	–
Input Voltage Swing	Δ VSDI	Set ATTEN_EN = 1 for Δ VSDI > 1V _{pp}	100	–	2000	mV _{p-pd}	–
Output Voltage Swing	Δ VOD	default	300	400	500	mV _{p-pd}	–
		see DRIVER_1 register (0x01) addresses 8 & 9 in 4.15.14 Host Register Map .	600	800	1000	mV _{p-pd}	–
Input Trace Equalization	–	LOW	Recommended setting for 0 to 10 inches of FR4			–	
		MED	Recommended setting for 10 to 20 inches of FR4			–	
		HIGH	Recommended setting for >20 inches of FR4			–	

Table 2-2: AC Electrical Characteristics (Continued)

Parameter	Symbol	Conditions	Min	Typ	Max	Units	Notes
Output De-Emphasis	-	OFF - 0	-	0	-	dB	-
		ON - 0	-	0	-	dB	-
		ON - 1	-	0.7	-	dB	-
		ON - 2	-	1.3	-	dB	-
		ON - 3	-	2	-	dB	-
		ON - 4	-	2.6	-	dB	-
		ON - 5	-	3.3	-	dB	-
		ON - 6	-	4	-	dB	-
		ON - 7	-	4.7	-	dB	-
Input Jitter Tolerance	-	square-wave modulated jitter	0.8	-	-	UI	-
Loop Bandwidth	BW _{LOOP} (270Mb/s)	KBB = VCC	-	170	-	kHz	-
		KBB = FLOAT	-	340	-	kHz	-
		KBB = GND	-	680	-	kHz	-
	BW _{LOOP} (1485Mb/s)	KBB = VCC	-	0.875	-	MHz	-
		KBB = FLOAT	-	1.75	-	MHz	-
		KBB = GND	-	3.5	-	MHz	-
	BW _{LOOP} (2970Mb/s)	KBB = VCC	-	1.75	-	MHz	-
		KBB = FLOAT	-	3.5	-	MHz	-
		KBB = GND	-	7.0	-	MHz	-
PLL Lock Time (asynchronous)	t _{alock}	-	0.5	1	ms	-	
PLL Lock Time (synchronous)	t _{sllock}	CLF = 47nF, SD/ \overline{HD} = 0	-	0.5	4	μs	-
		CLF = 47nF, SD/ \overline{HD} = 1	-	5	10	μs	-
Serial Data output Jitter Intrinsic (DDO0)	t _{OJ(270MB/s)}	KBB = FLOAT PRN 2 ²³ -1 test pattern	-	0.01	-	UI	-
	t _{OJ(1485MB/s)}	KBB = FLOAT PRN 2 ²³ -1 test pattern	-	0.03	-	UI	-
	t _{OJ(2970MB/s)}	KBB = FLOAT PRN 2 ²³ -1 test pattern	-	0.05	-	UI	-
Output Rise/Fall Time	tr/f	20% to 80% (400mV swing)	-	65	-	ps	-
		20% to 80% (800mV swing)	-	80	-	ps	-
Output Rise/Fall Time Mismatch	-	-	-	-	15	ps	-

Table 2-2: AC Electrical Characteristics (Continued)

Parameter	Symbol	Conditions	Min	Typ	Max	Units	Notes
Eye Cross Shift	–	percentage of signal amplitude	–	–	5	%	–
Power Supply Noise Rejection	–	50 - 100Hz	–	100	–	mV _{p-p}	–
		100Hz - 10MHz	–	40	–	mV _{p-p}	–
		10MHz - 1.485GHz	–	10	–	mV _{p-p}	–

3. Input/Output Circuits

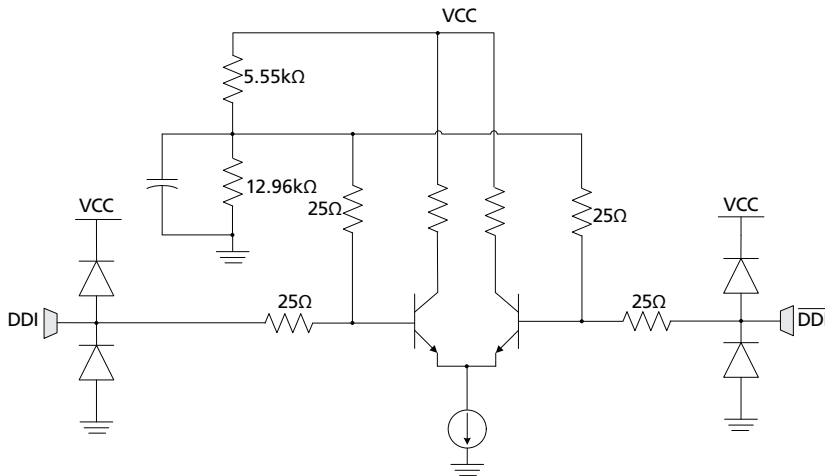

Figure 3-1: High-speed Inputs ($\overline{\text{DDI0}}$, $\overline{\text{DDI1}}$, $\overline{\text{DDI2}}$, $\overline{\text{DDI3}}$)

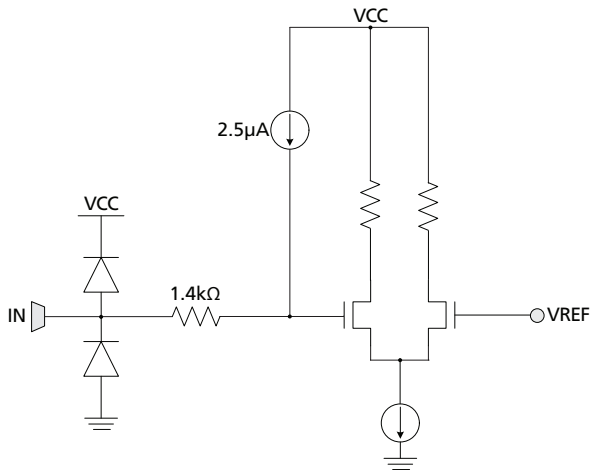

Figure 3-2: Low-speed Input with weak internal pull-up ($\overline{\text{HIF}}$, $\overline{\text{DDO1_DISABLE}}$)

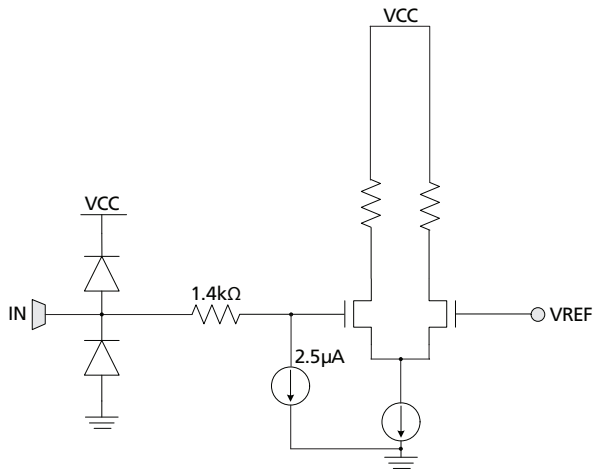

Figure 3-3: Low-speed Input with weak internal pull-down (DDI_SEL0, DDI_SEL1)

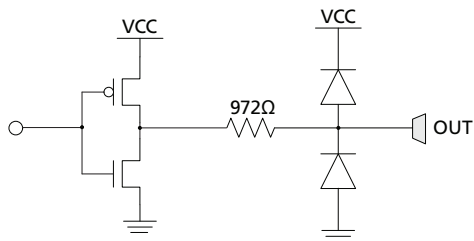

Figure 3-4: Low-speed Outputs (LOCKED, LOS, SD/HD)

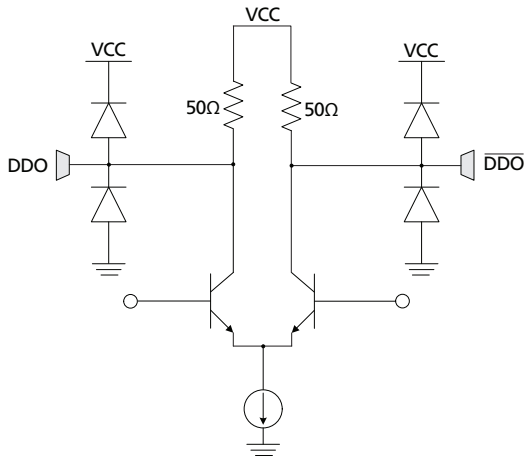

Figure 3-5: High-speed Outputs ($\overline{\text{DDO1}}/\overline{\text{RCO}}$, DDO1/RCO, $\overline{\text{DDO0}}$, DDO0)

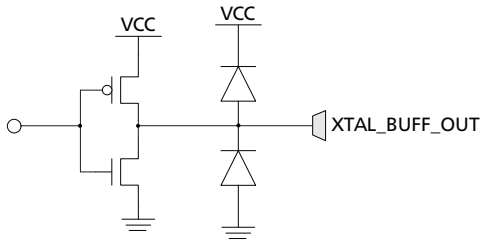

Figure 3-6: Crystal Buffered Output (XTAL_BUF_OUT)

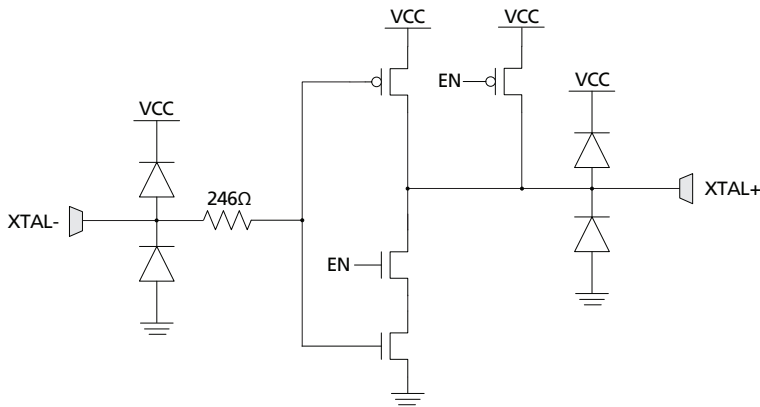

Figure 3-7: High-speed Crystal Oscillator I/O (XTAL-, XTAL+)

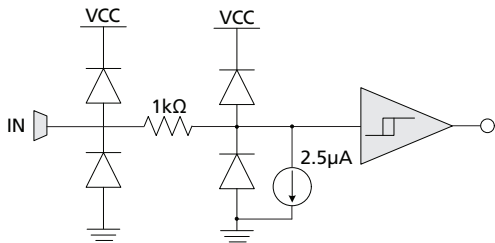

Figure 3-8: SPI Inputs/EQ Ctrl ($\overline{CS}/EQ3_EN$, SCK/EQ2_EN, SDI/EQ0_EN)

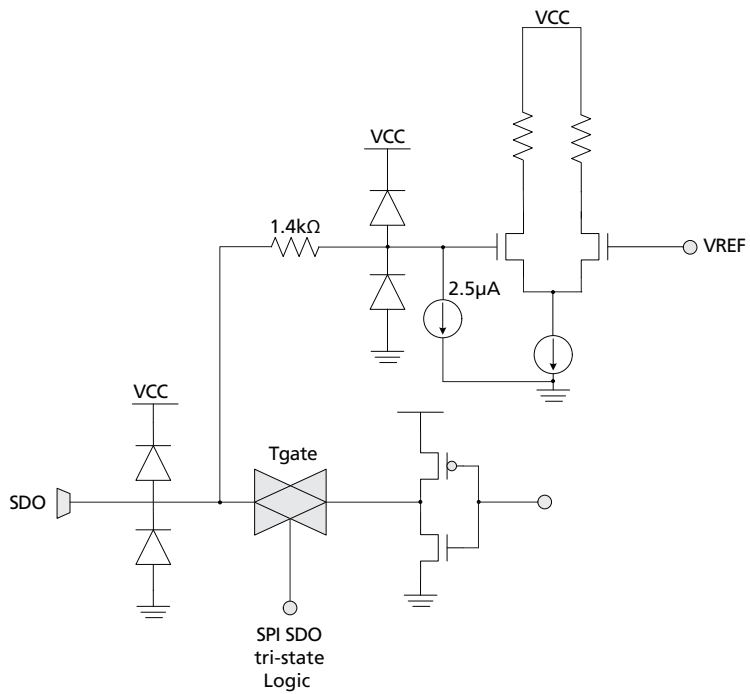

Figure 3-9: SPI Output/EQ Control (SDO/EQ1_EN)

4. Detailed Description

The GS2986 is a multi-standard reclocker for serial digital SDTV signals operating at 270Mb/s, and HDTV signals operating at 1.485Gb/s, 1.485/1.001Gb/s, 2.97Gb/s and 2.97/1.001Gb/s.

4.1 Serial Data Input

The GS2986 features four differential input buffers.

The serial data input signal is connected to the DDI0/ $\overline{\text{DDI0}}$, DDI1/ $\overline{\text{DDI1}}$, DDI2/ $\overline{\text{DDI2}}$ and DDI3/ $\overline{\text{DDI3}}$ input pins of the device.

Input signals can be single-ended or differential, DC or AC-coupled.

The input circuit is self-biasing, to allow for simple AC or DC-coupling of input signals to the device.

4.2 Modes of Operation

The GS2986 has two modes of operation: Legacy Mode ($\overline{\text{HIF}} = \text{HIGH}$) and SPI Mode ($\overline{\text{HIF}} = \text{LOW}$).

In Legacy Mode, chip functions are controlled via pins only, and offers limited control of input Equalization.

In SPI mode, access is gained to extended digital controls like: Bypass, Autobypass, Auto/Manual selection, Control status inputs or outputs, changes to KBB settings, additional EQ and DE settings as well as access to additional features such as LOS adjustment, polarity invert, auto-mute, etc.

4.3 Input Trace Equalization

The GS2986 features adjustable trace equalization to compensate for PCB trace dielectric losses at 1.5GHz.

The trace equalization has three peak-gain settings. The maximum peak gain value is optimized for compensating the high-frequency losses associated with 25 inches of 5-mil stripline in FR4 material. For boards with different striplines or materials, users can experiment to find the EQ setting which optimizes their system performance.

These settings are accessible via the serial host interface.

Each serial digital input; DDI, $\overline{\text{DDI}}$ includes a pin EQn_EN to turn its trace equalizer on or off. When a pin EQn_EN is tied LOW or left unconnected, the trace equalization for input n is set to LOW.

When an EQn_EN pin is tied HIGH, and input n is selected, the trace equalization for input n is set to Medium.

Table 4-1: Input Trace Equalization Operation

EQn_EN Setting	Trace Equalization
LOW	Low
HIGH	Medium

The default peak-gain setting upon power-up is optimized for compensating the high-frequency losses associated with approximately 10 inches of 5-mil stripline in FR4 material.

The EQn_EN pins are multiplexed with the serial host interface pins when pin $\overline{\text{HIF}}$ is tied high, as shown in [Table 4-2](#):

Table 4-2: EQn_EN Pins Multiplexed

Pin	Function
SDI/EQ0_EN	Active-high logic input to enable trace-equalization for high-speed input channel 0.
SDO/EQ1_EN	Active-high logic input to enable trace-equalization for high-speed input channel 1.
SCK/EQ2_EN	Active-high logic input to enable trace-equalization for high-speed input channel 2.
$\overline{\text{CS}}$ /EQ3_EN	Active-high logic input to enable trace-equalization for high-speed input channel 3.

4.4 4:1 Input Mux

The GS2986 incorporates a 4:1 input mux, which allows the connection of four independent streams of video/data. There are four differential inputs (DDI[3:0] / $\overline{\text{DDI}}$ [3:0]). The active channel can be selected via the DDI_SEL[1:0] pins as shown in [Table 4-3](#).

Table 4-3: Input Selection Table

DDI_SEL[1:0]	Selected Input
00	DDI0
01	DDI1
10	DDI2
11	DDI3

The DDI_SEL pins include internal pulldowns which pull the input voltage LOW if either pin is unconnected. Active circuitry associated with the input buffers and trace EQ can only be turned on for the selected input. Inputs which are not selected have their input buffers and trace EQs turned OFF to save power. Unused inputs can be either left floating, or tied to VCC.

4.5 Crystal Buffer

The GS2986 features a crystal buffer supporting a Gennum recommended external 27MHz crystal. The GS2986 requires an external 27MHz reference clock for correct operation. This reference clock is generated by connecting a crystal to the XTAL- and XTAL+ pins of the device.

Alternately, a 27MHz external clock source can be connected to the XTAL- pin of the device, while the XTAL+ pin should be left floating.

4.6 LOS (Loss Of Signal) Detection

The LOS (Loss Of Signal) status pin is an active-high output that indicates when the serial digital input signal selected at the 4:1 input mux is invalid. In order for this output to be asserted, transitions must not be present for a period of $t_{LA} = 5 - 10\mu s$. After this output has been asserted, LOS will de-assert within $t_{LD} = 0 - 5\mu s$ after the appearance of a transition at the DDix input. See [Figure 4-1](#).

This signal is HIGH (signal lost), when the number of data edges within a window is below a defined threshold. The output is automatically muted when LOS is detected.

This signal is LOW (signal valid), when the number of data edges within a window is above a defined threshold. See [Table 4-4](#).

Table 4-4: LOS Operation

LOS	Signal
HIGH	Invalid
LOW	Valid

The LOS function is operational for all operating modes of the device.

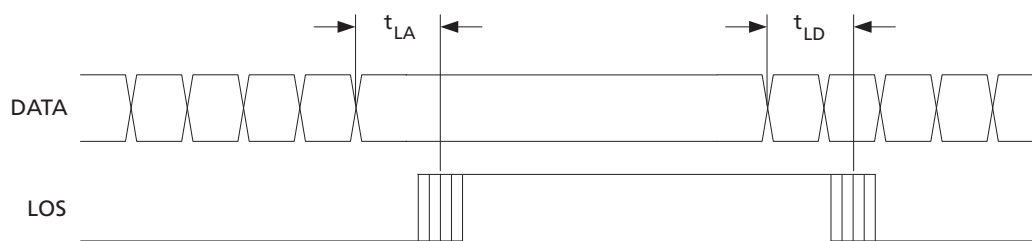

Figure 4-1: LOS Signal Timing

The LOS detector has two major modes. In legacy mode, a simple edge-based detector is used to monitor the received signal at the output of the data slicer. Since the incoming signal has undergone considerable gain by this point, the legacy detector can be more susceptible to false de-assertion of LOS for unused channels which experience significant cross-talk from adjacent active channels.

The new LOS detector uses a measure of both signal amplitude and duration to minimize false detection of the impulse like signals that are characteristic of cross-talk. In this mode, the signal is tapped off at the output of the equalizer stage, prior to the high gain buffers.

The threshold setting within the detector can be adjusted to increase or decrease its sensitivity. Gennum recommends using the least sensitive threshold level. This provides the most margin against false de-assertion of LOS.

Table 4-5: Suggested LOS Threshold Settings

		LOS Detection Method Select	LOS Threshold Adjust
Input Signal Amplitude	>250mV	0x1	0x0
	200mV to 250mV	0x1	0x1
	150mV to 200mV	0x1	0x2
	<150mV	0x1 or 0x0	0x3

The LOS mode can be selected by using the host interface, in register TOP_1 (address 0x02).

4.7 Serial Digital Reclocker

The output of the Equalizer is fed to the reclocker. The function of the reclocker is to re-time the input signal and to generate system clocks.

The reclocker operates at three frequencies; 2.97Gb/s, 1.485Gb/s and 270Mb/s, and provides a minimum input jitter tolerance of 0.8UI to square-wave-modulated jitter at these rates.

When there is no serial input signal, the internal clock maintains a frequency close to the expected incoming data rate by locking to the external reference crystal.

4.8 Lock Detection

The lock detect block indicates, via the active-high LOCKED signal, when the device has achieved lock to the incoming data stream.

The lock logic within the GS2986 includes a system that monitors the frequency and the phase of the incoming data, as well as a monitor to detect harmonic lock.

Table 4-6: Lock Operation

LOCKED	Status
HIGH	Locked
LOW	Not locked

The LOCKED output signal is also available via the host interface.

4.8.1 Lock Detect and Asynchronous Lock

The reference crystal is used to assist the PLL in achieving short lock time. The lock detection algorithm is a continuous process, which begins at device power up or after a system reset, and continues until the device is powered down.

The asynchronous lock time is defined as the time it takes the device to lock when a video signal is first applied to the serial digital inputs, or when the digital video signal rate changes.

The synchronous lock time is defined as the time it takes the device to lock to a signal which has been momentarily interrupted.

4.9 Serial Data Output

The GS2986 features two current-mode differential output drivers, each capable of driving a maximum of 800mV_{pp} differential, into an external 100Ω differential load.

Each of the GS2986's output buffers include two on-chip, 50Ω termination resistors.

4.9.1 Output Signal Interface Levels

The serial digital outputs of the GS2986 are compatible when DC-coupled with all Gennum serial digital interface products that feature a differential LVPECL or CML receiver designed for SDI applications and operate from 3.3V or 2.5V supplies. This includes but is not limited to: GS2978, GS2988, and GS2989.

The serial digital data inputs are also compatible when DC-coupled with LVPECL or CML differential outputs from crosspoint switches which operate from 3.3V or 2.5V supplies. This includes but is not limited to: GS2974A, GS2974B, and GS2984 equalizers.

4.9.2 Adjustable Output Swing

It is possible, via the host interface, to force the output swing to 400mV_{pp} or 800mV_{pp} differential, when the outputs are terminated with 50Ω loads.

The default output swing upon power-up is 400mV_{pp} differential.

4.9.3 Output De-emphasis

The GS2986 features adjustable output de-emphasis to compensate for PCB trace dielectric losses.

The output de-emphasis has eight settings, evenly distributed from a minimum of 0dB (output de-emphasis OFF) to a peak de-emphasis setting that is optimized for compensating the high-frequency losses associated with approximately 20 inches of 5-mil stripline in FR4 material. These settings are accessible via the serial host interface.

The action of the de-emphasis settings is to attenuate the trailing edge of the output data waveform relative to the output swings set through the host interface.

De-emphasis is turned OFF when in Bypass mode.

The default de-emphasis setting upon power-up is 0dB (OFF).

NOTE: Changing the de-emphasis setting will vary both V1 & V2 (see [Figure 4-2](#)).

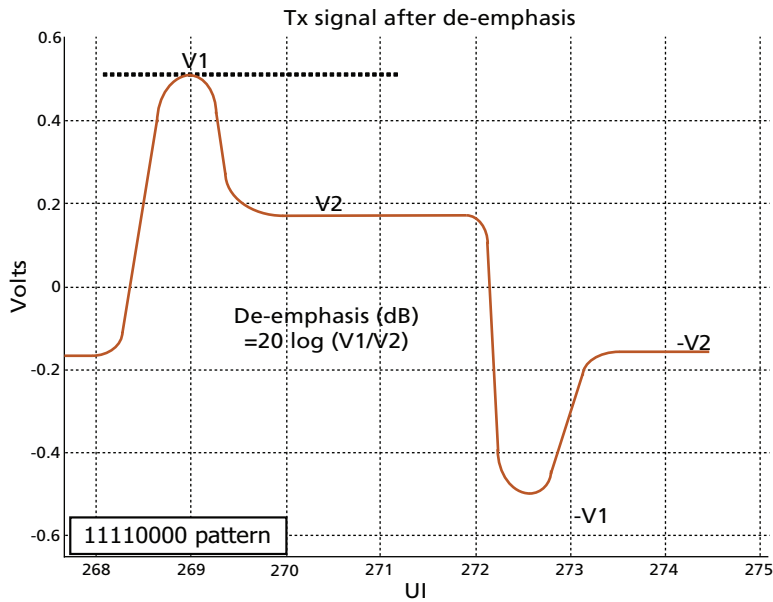

Figure 4-2: De-emphasis Waveform

4.10 Automatic and Manual Data Rate Selection

The GS2986 can be configured to manually lock to a specific data rate or automatically search for and lock to the incoming data rate. The default configuration is AUTO mode. This can be changed via the host interface.

In AUTO mode, the SS[1:0] registers become read only, and the bit pattern indicates the data rate at which the PLL is currently locked to (or previously locked to). The search algorithm cycles through the data rates and starts over if that data rate is not found (see Figure 4-3).

A “search algorithm” cycles through the supported data rates until lock is achieved, as shown in Figure 4-3 below.

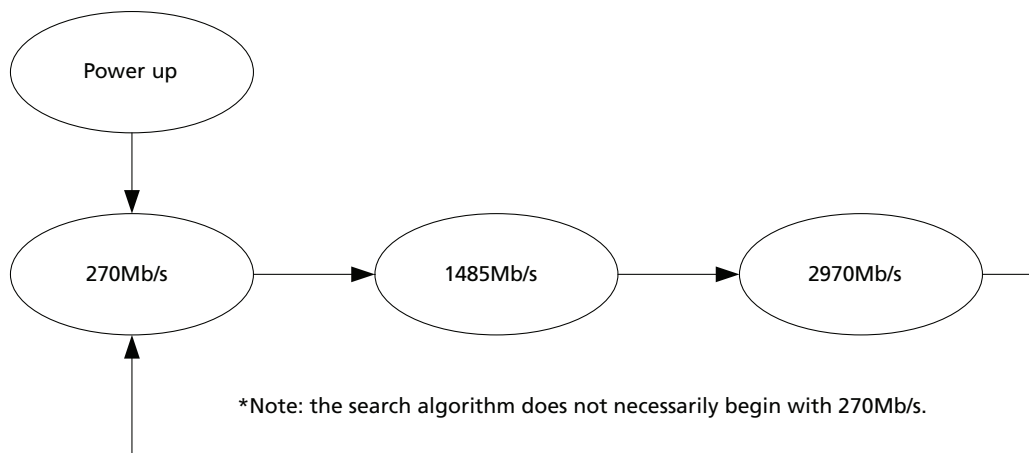

Figure 4-3: GS2986 Automatic Mode Search Algorithm

In MANUAL mode, the SS[1:0] registers become read or write pins become inputs and the data rate can be programmed. In this mode, the search algorithm is disabled and the GS2986's PLL

will only lock to the data rate selected in accordance with Table 4-7.

Table 4-7: Data Rate Indication/Selection Bit Pattern

SS[1:0]	Data Rate (Mb/s)
0	Reserved
1	270
2	1485 or 1485/1.001
3	2970 or 2970/1.001

4.11 SD/ $\overline{\text{HD}}$ Indication

The SD/ $\overline{\text{HD}}$ signal indicates the output data rate of the device and can be connected to the SD/ $\overline{\text{HD}}$ input pin of dual slew rate cable drivers such as the GS2988.

When this signal is HIGH, the data rate is 270Mb/s. This signal is LOW for all other data rates.

This signal is also LOW when the device is operating in bypass mode (Auto-bypass and User-bypass).

The SD/ $\overline{\text{HD}}$ signal is LOW when the device is not locked.

4.12 Bypass Mode

In bypass mode, the GS2986 passes the data at the inputs, directly to the output. There are two register bits that control the bypass function: BYPASS and AUTOBYPASS.

The BYPASS bit is an active-high signal which forces the GS2986 into bypass mode for as long as the bit is asserted HIGH.

The AUTOBYPASS bit is an active-high signal that places the GS2986 into bypass mode only when the PLL has not locked to a data rate.

Table 4-8: Bypass Modes

Bypass	Autobypass	Device Operation
HIGH	X	Bypass Mode
LOW	HIGH	Bypass Mode if the PLL has not locked to a data rate
LOW	LOW	Power-up default. Normal Operation, part always tries to lock to the incoming data stream.

Note that if BYPASS is HIGH, this will override the AUTOBYPASS functionality.

When the GS2986's PLL is not locked and BYPASS = LOW and AUTOBYPASS = LOW, the serial digital output DDO/ $\overline{\text{DDO}}$ will produce invalid data.

The AUTOBYPASS function will bypass unsupported (non-reclocked) SMPTE SDI signal rates without producing bit errors: 143Mb/s, 177Mb/s, 360Mb/s, 540Mb/s.

4.13 DVB-ASI

The GS2986 also reclocks DVB-ASI signals at 270Mb/s. In auto mode, the device will automatically lock to the incoming 270Mb/s signal. In manual mode, the SS[1:0] pins must be set to 01 (270Mb/s) to ensure proper operation.

4.14 Output Mute and Data/Clock Output Selection

The $\overline{\text{DATA_MUTE}}$ register is provided to allow muting of the serial digital data output.

Setting $\overline{\text{DATA_MUTE}} = \text{LOW}$ will force the serial digital outputs $\overline{\text{DDO}}/\overline{\text{DDO}}$ to mute (statically latch HIGH) under all conditions and operating modes.

The $\overline{\text{DDO1_DISABLE}}$ pin is provided to allow the second data/clock output to be powered down.

When $\overline{\text{DDO1_DISABLE}}$ is set LOW, the serial digital clock outputs $\overline{\text{DDO1/RCO}}$ and $\overline{\text{DDO1/RCO}}$ are muted and the driver is powered-down.

The $\overline{\text{DATA/CLOCK}}$ register is provided to allow the second output to emit a copy of the reclocked serial data or the recovered clock. In Legacy mode, the default is DATA output.

Table 4-9: Configuration of GS2986 Output Drivers and Mute/Disable Pins

$\overline{\text{DATA_MUTE}}$	$\overline{\text{DDO1_DISABLE}}$	$\overline{\text{DATA/CLOCK}}$	DDO0	DDO1/RCO
1	1	0	DATA	CLOCK
1	1	1	DATA	DATA
0	1	0	MUTE	CLOCK
0	1	1	MUTE	MUTE
1	0	X	DATA	Power down
0	0	X	MUTE	Power down

4.15 Host Interface

4.15.1 Introduction

The GS2986 offers a Serial Peripheral Interface (SPI) to access advanced features and programmability. The polarity of the $\overline{\text{HIF}}$ pin tells the GS2986 whether or not the host interface is active ($\overline{\text{HIF}} = 0$) or in legacy mode ($\overline{\text{HIF}} = 1$).

Using the host interface, it is possible to override the control pin settings, and such settings will persist until the device has been powered-down and/or reset. The host interface is capable of

reading hard-wired pin configuration, pin override settings and the values of all status monitoring pins.

There is an optional 3-state feature available in the Control Status Registers (CSR) that puts the SPI SDO to high-impedance when it's not being used (Register: TOP_1, bit: 2).

The maximum operating speed of the SPI is 10MHz.

4.15.2 Legacy Mode & Start-up

In legacy mode, basic configuration of the device including a subset of equalizer settings are available at the pin level. In this mode, register settings are automatically set to default so that the IC is live at power-up.

4.15.3 Host Interface Mode & Start-up

In host interface mode, the user gains access to Control and Status Registers (CSRs) that manage advanced features. In this mode, equalizer and de-emphasis settings are set through the CSR.

The SPI control port is functional at start-up without the need for a separate, external reset signal. However, all internal registers must be set to their default state by issuing a required Reset Command via the SPI.

This is done by setting the \bar{R} bit (reset) LOW in the command word. This will guarantee the CSR will not start up in a random state.

A simple way to issue the required reset of the CSR is to hold the slave device's SDI input LOW for an entire 64 cycle WRITE communication. Details of the WRITE operation are found in section 4.15.6 below.

4.15.4 Clock & Data Timing

The SPI signals are Serial Data Input (SDI), Serial Data Output (SDO), active-low Chip Select (\bar{CS}), and Serial Clock Input (SCK). The host interface operates in SPI Mode 0, i.e. the SDI input will latch data in on the rising edge of SCK. The SDO data output will transition on falling edges of SCK. Data is transmitted or received on the SPI port MSB first LSB last.

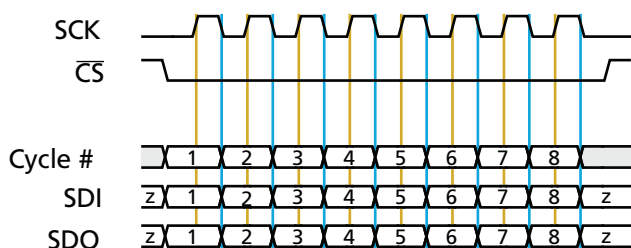

Figure 4-4: Data Clock Alignment