



Chipsmall Limited consists of a professional team with an average of over 10 year of expertise in the distribution of electronic components. Based in Hongkong, we have already established firm and mutual-benefit business relationships with customers from,Europe,America and south Asia,supplying obsolete and hard-to-find components to meet their specific needs.

With the principle of "Quality Parts,Customers Priority,Honest Operation,and Considerate Service",our business mainly focus on the distribution of electronic components. Line cards we deal with include Microchip,ALPS,ROHM,Xilinx,Pulse,ON,Everlight and Freescale. Main products comprise IC,Modules,Potentiometer,IC Socket,Relay,Connector.Our parts cover such applications as commercial,industrial, and automotives areas.

We are looking forward to setting up business relationship with you and hope to provide you with the best service and solution. Let us make a better world for our industry!



Contact us

Tel: +86-755-8981 8866 Fax: +86-755-8427 6832

Email & Skype: info@chipsmall.com Web: www.chipsmall.com

Address: A1208, Overseas Decoration Building, #122 Zhenhua RD., Futian, Shenzhen, China





GS2988 Dual-Slew-Rate, Cable Driver with 3Gb/s Capability

Features

- SMPTE 424M, SMPTE 292M and SMPTE 259M compliant
- Supports DVB-ASI at 270Mb/s
- Supports data rates from 270Mb/s to 2.97Gb/s
- Wide common-mode range input buffer
 - ◆ 100mV sensitivity
 - ◆ supports DC-coupling to industry-standard differential logic
 - ◆ on-chip 100Ω differential data input termination
- Input signal trace equalization
- Differential coaxial-cable-driving output
 - ◆ selectable slew rates
 - ◆ adjustable output swing from 500mV_{pp} to 1800mV_{pp}
 - ◆ DISABLE control
- Robust output signal presence function
- Excellent output eye quality
- Power supply operation at 3.3V or 2.5V
- 110mW power consumption (2.5V supply)
- Operating temperature range: -40°C to +85°C
- Small footprint QFN package (4mm x 4mm)
 - ◆ Drop-in compatible to the GS2978
- Pb-free and RoHS compliant

Applications

- SMPTE 424M, SMPTE 292M and SMPTE 259M coaxial cable serial digital interfaces

Description

The GS2988 is a high-speed BiCMOS integrated circuit designed to drive one to two 75Ω coaxial cables.

The GS2988 may drive data rates up to 2.97Gb/s and provides two selectable slew rates in order to achieve compliance to SMPTE 424M, SMPTE 292M and SMPTE 259M.

The GS2988 accepts industry-standard differential input levels including LVPECL and CML.

Input trace equalization compensates for up to 10 inches of FR4 trace loss while in HD and 3G modes. This feature can be disabled using the $\overline{\text{EQ_EN}}$ pin.

The $\overline{\text{DISABLE}}$ pin powers-down the entire device.

The GS2988 features adjustable output swing using an external bias resistor. The single-ended output swing is adjustable from 500mV_{pp} to 1800mV_{pp}.

An output signal presence function, the $\overline{\text{OSP}}$ pin, indicates whether an active signal is present at the output of the GS2988.

The GS2988 can be powered from either a 3.3V or a 2.5V supply. Power consumption is typically 110mW using a 2.5V power supply.

The GS2988 is Pb-free, and the encapsulation compound does not contain halogenated flame retardant.

This component and all homogeneous subcomponents are RoHS compliant.

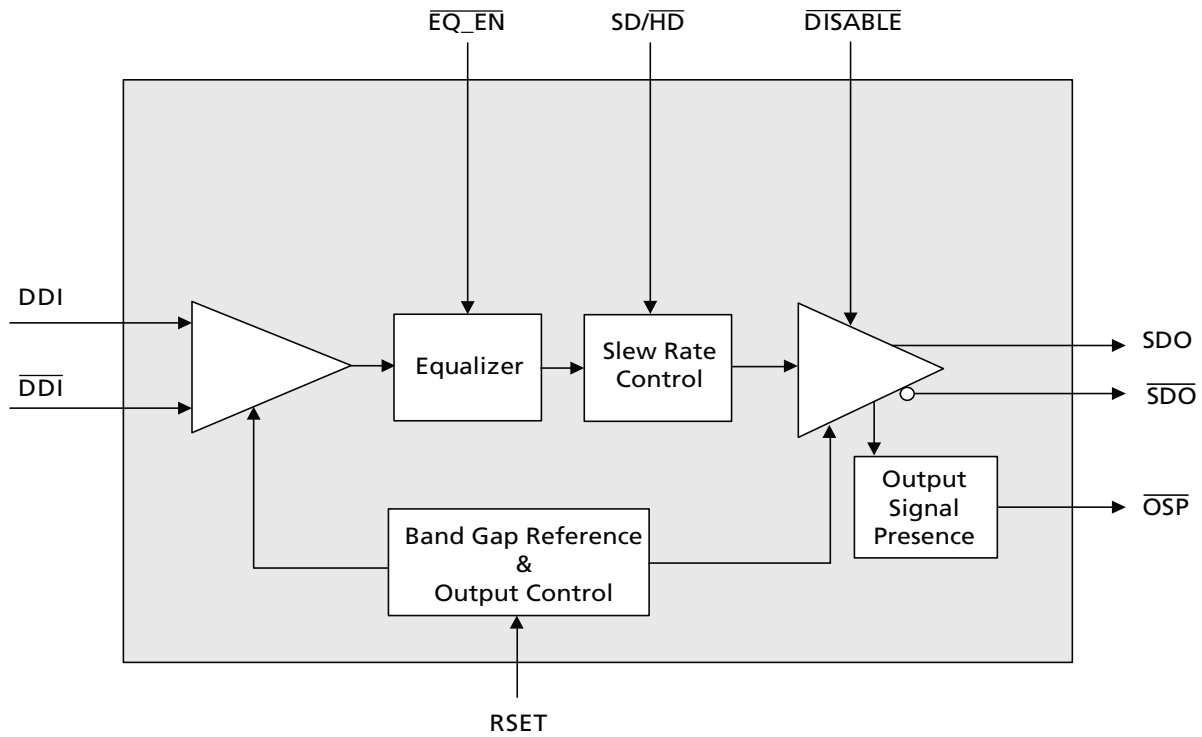

Functional Block Diagram

Revision History

Version	ECR	PCN	Date	Changes and/or Modifications
4	155552	–	December 2010	Corrected the Marking Diagram .
3	155359	–	November 2010	Clarified the functionality of the $\overline{EQ_EN}$ pin in Table 1-1: Pin Descriptions and throughout the document.
2	155070	–	October 2010	Updated Typical Application Circuit .
1	153602	–	February 2010	Converted document to Data Sheet.
0	153455	–	January 2010	Converted document to Preliminary Data Sheet. Changed Additive jitter numbers in Table 2-2: AC Electrical Characteristics .
B	152690	–	October 2009	Updates to Section 2. Electrical Characteristics . Corrections to Section 3. Input/Output Circuits .
A	151623	–	April 2009	New document.

Contents

Features.....	1
Applications.....	1
Description.....	1
Revision History	2
1. Pin Out.....	4
1.1 Pin Assignment	4
1.2 Pin Descriptions	4
2. Electrical Characteristics	5
2.1 Absolute Maximum Ratings	5
2.2 DC Electrical Characteristics	6
2.3 AC Electrical Characteristics	7
3. Input/Output Circuits	8
4. Detailed Description.....	9
4.1 Serial Data Input	9
4.2 Input Trace-equalization	9
4.3 Serial Data Output	9
4.3.1 Slew Rate Selection (Rise/Fall Time Requirement).....	9
4.4 Output Disable	10
4.5 Output Signal Presence Indicator (\overline{OSP})	10
4.6 Output Amplitude (RSET)	10
4.7 Output Return Loss Measurement	12
5. Application Information	13
5.1 PCB Layout	13
5.2 Typical Application Circuit	13
6. Package & Ordering Information	14
6.1 Package Dimensions	14
6.2 Recommended PCB Footprint	15
6.3 Packaging Data	15
6.4 Solder Reflow Profiles	16
6.5 Marking Diagram	16
6.6 Ordering Information	17

1. Pin Out

1.1 Pin Assignment

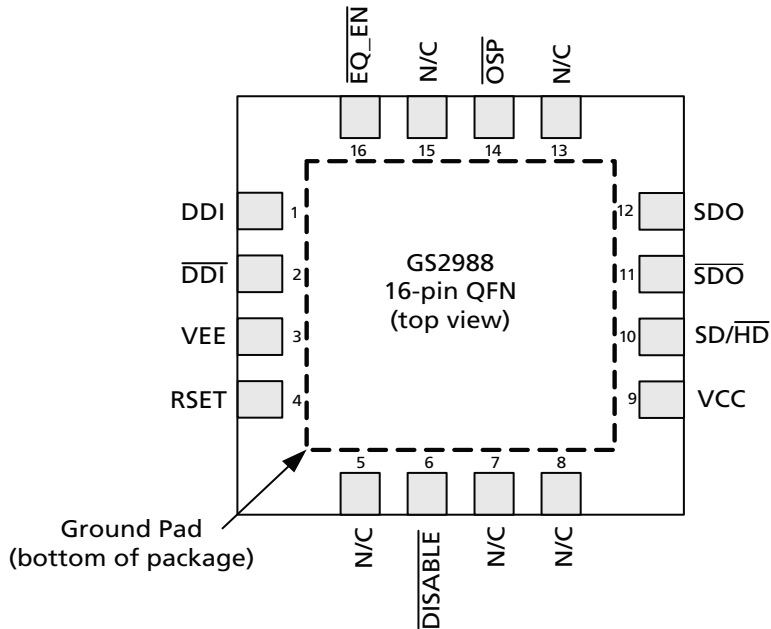

Figure 1-1: 16-Pin QFN

1.2 Pin Descriptions

Table 1-1: Pin Descriptions

Pin Number	Name	Type	Description
1, 2	DDI, $\overline{\text{DDI}}$	Input	Serial data differential input.
3	VEE	Power	Most negative power supply connection for the input buffer and core. Connect to GND.
4	RSET	Input	External output amplitude control resistor connection.
5, 7, 8, 13, 15	N/C	–	No Connect. These pins are not connected internally.
6	$\overline{\text{DISABLE}}$	Input	Control signal input. When set LOW, the entire device is powered-down. When set HIGH, the $\text{SDO}/\overline{\text{SDO}}$ pins will output a serial data signal. NOTE: if this pin is left floating, the serial data output will be enabled .
9	VCC	Power	Most positive power supply connection. Connect to 3.3V or 2.5V.

Table 1-1: Pin Descriptions

Pin Number	Name	Type	Description
10	SD/H \bar{D}	Input	Control signal input. When set HIGH, the serial data output will meet the SMPTE 259M rise/fall time specification. When set LOW, the serial output will meet the SMPTE 292M and SMPTE 424M rise/fall time specification. NOTE: if this pin is left floating, the serial data output will meet the SMPTE 259M rise/fall time specification.
11, 12	\overline{SDO} / SDO	Output	Serial data differential output.
14	\overline{OSP}	Output	Output signal presence status signal output. Signal levels are LVCMOS/LVTTL compatible. Indicates presence of a valid output signal. When the \overline{OSP} pin is LOW, a good input signal has been detected within the output stage pre-driver. When this pin is HIGH, the output signal is invalid at the output of the pre-driver.
16	$\overline{EQ_EN}$	Input	Control signal input. When set LOW, trace-equalization is turned ON. When set HIGH, trace-equalization is turned OFF. NOTE 1: if this pin is left floating, trace-equalization is turned OFF. NOTE 2: this pin must be pulled HIGH or left floating for operation in SD mode.
-	Center Pad	Power	Connect to most negative power supply plane following the recommendations in Recommended PCB Footprint on page 15 .

2. Electrical Characteristics

2.1 Absolute Maximum Ratings

Parameter	Value
Supply Voltage	-0.5V to 3.6 V _{DC}
Input ESD Voltage	2.5kV
Storage Temperature Range	-50°C < T _s < 125°C
Input Voltage Range (any input)	-0.3 to (V _{CC} +0.3)V
Operating Temperature Range	-40°C to +85°C
Solder Reflow Temperature	260°C

NOTE: Absolute Maximum Ratings are those values beyond which damage to the device may occur. Functional operation under these conditions or at any other condition beyond those indicated in the AC/DC Electrical Characteristic sections is not implied.

2.2 DC Electrical Characteristics

Table 2-1: DC Electrical Characteristics

$V_{CC} = 3.3V \pm 5\%$ or $2.5V \pm 5\%$; $T_A = -40^{\circ}C$ to $+85^{\circ}C$, unless otherwise shown

Parameter	Symbol	Conditions	Min	Typ	Max	Units	Notes
Supply Voltage	V_{CC}	3.3V Typical	3.135	3.3	3.465	V	–
		2.5V Typical	2.375	2.5	2.625	V	–
Power Consumption (2.5V)	P_D	SDO/ \overline{SDO} enabled	–	110	130	mW	1
		SDO/ \overline{SDO} disabled	–	3	5	mW	1
Power Consumption (3.3V)		SDO/ \overline{SDO} enabled	–	155	183	mW	1
		SDO/ \overline{SDO} disabled	–	4	6	mW	1
Supply Current	I_S	VCC = 3.3V	–	47	53	mA	1
		VCC = 2.5V	–	44	50	mA	1
		Power-down	–	1	1.8	mA	1
Output Voltage	V_{CMOUT}	Common mode	–	$V_{TERM} - V_{OUT}$	–	V	–
Input Voltage	V_{CMIN}	Common mode	$1.4 + \Delta V_{DDI}/2$	–	$V_{CC} - \Delta V_{DDI}/2$	V	–
SD/ \overline{HD} , $\overline{DISABLE}$, EQ_En Input	V_{IH}	$I_{IH} \leq 150\mu A$	1.7	–	–	V	–
	V_{IL}	$I_{IL} \leq 150\mu A$	–	–	0.8	V	–
OSP Drive Strength	–	–	2	–	–	mA	–

NOTES:

1. Power consumed in GS2988 only. Termination resistors draw extra current.

2.3 AC Electrical Characteristics

Table 2-2: AC Electrical Characteristics

$V_{CC} = 3.3V \pm 5\%$ or $2.5V \pm 5\%$; $T_A = -40^\circ C$ to $+85^\circ C$, unless otherwise shown

Parameter	Symbol	Conditions	Min	Typ	Max	Units	Notes
Serial input data rate	DR_{SDO}	–	.27	–	2.97	Gb/s	1
Additive jitter	–	2.97Gb/s	–	10	–	ps _{p-p}	2
	–	1.485Gb/s	–	10	–	ps _{p-p}	2
	–	270Mb/s	–	30	–	ps _{p-p}	2
Rise/Fall time	t_r, t_f	SD/ \overline{HD} =0	–	–	135	ps	3
	t_r, t_f	SD/ \overline{HD} =1	400	–	800	ps	3
Mismatch in rise/fall time	$\Delta t_r, \Delta t_f$	HD/3G modes only	–	–	35	ps	–
Duty cycle distortion	–	SD/ \overline{HD} =0, 2.97Gb/s	–	–	14	ps	4, 5
	–	SD/ \overline{HD} =0, 1.485Gb/s	–	–	20	ps	4, 5
	–	SD/ \overline{HD} =1	–	–	50	ps	4, 5
Overshoot	–	SD/ \overline{HD} =0,	–	–	10	%	4
Output Return Loss	ORL	5 MHz – 1.485GHz	17	19	–	dB	6
		1.485GHz – 2.97GHz	13	15	–	dB	6
Output Voltage Swing	V_{OUT}	$R_{SET} = 75\Omega$	750	800	850	mV _{p-p}	4
Input Voltage Swing	ΔV_{DDI}	Guaranteed functional.	100	–	250	mV _{p-pd}	–
		Guaranteed to meet all published specifications.	250	–	2200	mV _{p-pd}	–
Output Enable Delay	–	–	–	–	100	ns	–
Output Disable Delay	–	–	–	–	80	ns	–

NOTES:

1. The input coupling capacitor must be set accordingly for lower data rates.
2. Turning on input trace equalization will reduce jitter in most applications.
3. Rise/Fall time measured between 20% and 80%.
4. Single-ended into 75Ω external load.
5. Calculated as the actual positive bit-width compared to the expected positive bit-width using a 1010 pattern.
6. ORL depends on board design. The GS2988 achieves this specification on Gennum's evaluation boards.

3. Input/Output Circuits

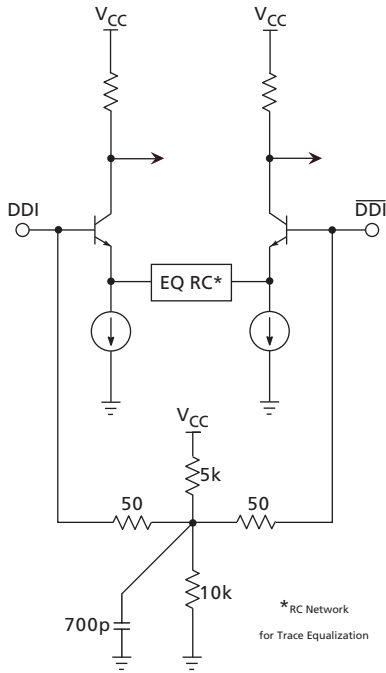

Figure 3-1: Differential Input Stage (DDI/DDI-bar)

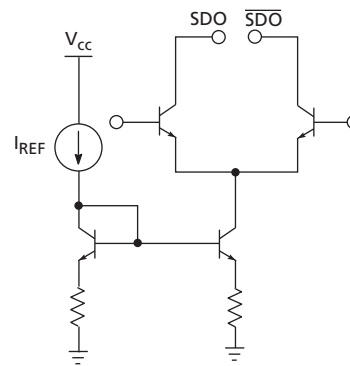

Figure 3-2: Differential Output Stage (SDO/SDO-bar)

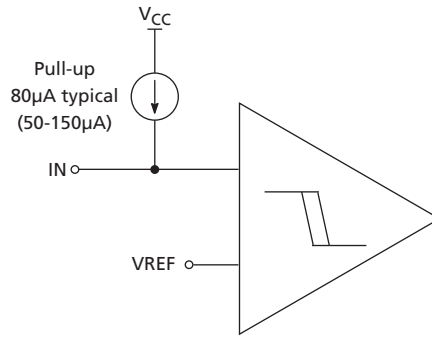

Figure 3-3: Control Input (DISABLE, SD/HD, EQ_EN)

4. Detailed Description

4.1 Serial Data Input

The GS2988 features a differential input buffer with on-chip 100Ω differential termination.

The serial data input signal is connected to the DDI and $\overline{\text{DDI}}$ input pins of the device.

Input signals can be single-ended or differential, DC or AC-coupled.

The serial data input buffer is capable of operation with any binary coded signal that meets the input signal level requirements, in the range of 270Mb/s to at least 2.97Gb/s.

The input circuit is self-biasing to allow for simple AC or DC-coupling of input signals to the device.

4.2 Input Trace-equalization

The GS2988 features fixed trace-equalization to compensate for PCB trace dielectric losses.

NOTE: This feature is not available in SD mode, and therefore trace-equalization must be disabled when operating in this mode.

The trace-equalization has two settings, OFF and ON. ON invokes a typical 3dB gain value at 1.5GHz. This value is optimized for compensating the high-frequency losses associated with approximately 10 inches of 5-mil stripline in FR4 material.

Table 4-1: Input Trace-Equalization

$\overline{\text{EQ_EN}}$	Function
0	Typical 3dB Trace Equalization
1	Trace Equalization OFF
Floating	Trace Equalization OFF

4.3 Serial Data Output

The GS2988 features a current-mode differential output driver capable of driving up to 1800mVpp single-ended into a 1m length of 75Ω cable terminated at both ends.

The output signal amplitude or swing is user configurable using an external RSET resistor.

The SDO/ $\overline{\text{SDO}}$ pin of the device provide the serial data outputs.

4.3.1 Slew Rate Selection (Rise/Fall Time Requirement)

The GS2988 supports two user-selectable output slew rates.

Control of the slew rate is determined by the setting of the SD/ $\overline{\text{HD}}$ input pin.

Table 4-2: Slew Rate Selection

SD/ $\overline{\text{HD}}$	Rise/Fall Time
0	SMPTE 424M & 292M compliant
1	SMPTE 259M compliant
Floating	SMPTE 259M compliant

4.4 Output Disable

The GS2988 supports an output disable function for the serial data differential output.

Control of this function is determined by the setting of the $\overline{\text{DISABLE}}$ control pin.

The serial output disable ($\overline{\text{DISABLE}}$), disables power to the entire device. When asserted LOW, the SDO/ $\overline{\text{SDO}}$ output driver is powered-down.

Table 4-3: Output Disable

$\overline{\text{DISABLE}}$	SDO/ $\overline{\text{SDO}}$
0	All Chip Power Down
1	Operational
Floating	Operational

4.5 Output Signal Presence Indicator ($\overline{\text{OSP}}$)

The GS2988 supports an output signal presence indicator function.

The output signal presence pin ($\overline{\text{OSP}}$) is an active-low output that indicates when a valid output signal has been detected at the pre-driver output.

The output signal presence function measures signal-edge energy to indicate that the pre-driver to the serial data outputs is toggling.

Table 4-4: Output Signal Presence Indicator

Pre-Driver Output	$\overline{\text{OSP}}$ Pin
Valid signal present	0
No valid signal present	1

4.6 Output Amplitude (RSET)

The output amplitude of the GS2988 can be adjusted by changing the value of the RSET resistor as shown in [Figure 4-1](#). For an 800mV_{p-p} output with a nominal $\pm 7\%$ tolerance, a value of 750 Ω is required. A $\pm 1\%$ SMT resistor should be used.

The RSET resistor is part of an internal DC feedback loop in the GS2988. The resistor should be placed as close as possible to the R_{SET} pin, and connected directly to the VCC plane (traces/wires may cause instability). In addition, the PCB capacitance should be minimized at this node by removing the PCB groundplane beneath the RSET resistor and the RSET pin.

NOTE: Care should be taken when considering layout of the RSET resistor. Please refer to [Section 5.1](#) for more details.

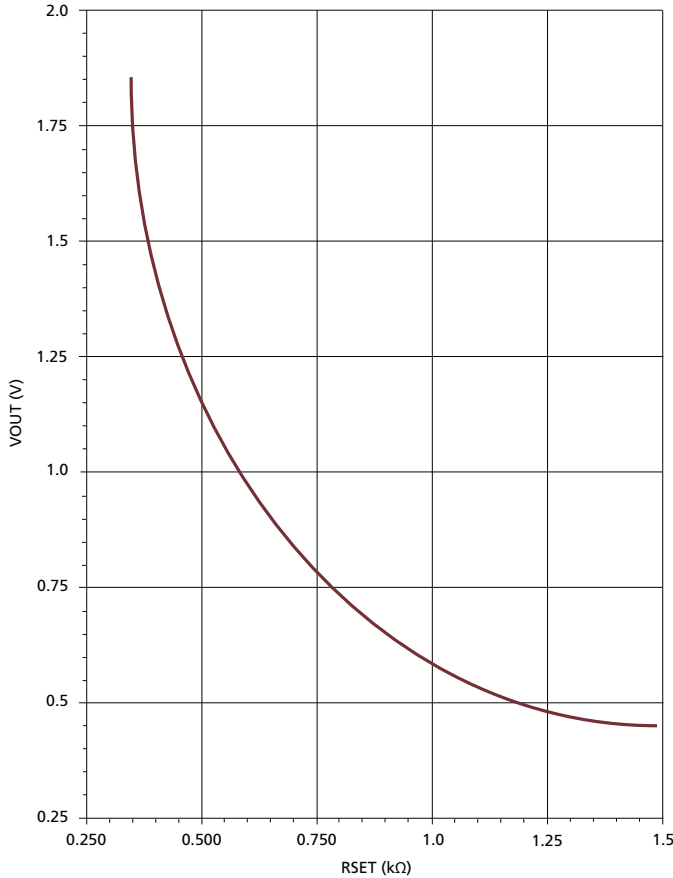

Figure 4-1: V_{OUT} vs. RSET

In order to determine the best starting value for Rset, the following formula should be used:

$$Rset = 8 \cdot (R_{trm} / V_{outppSE})$$

Where **V_{outppSE}** is in Volts, and both resistances are in Ω.

R_{trm} is the value of the termination resistors, which should be equal to the characteristic impedance of the cable, and is typically 75Ω.

The cable must be short (≤1m), and terminated at both ends for the formula to be valid.

Example: For a 75Ω cable, R_{trm} = 75Ω (at both ends), V_{outppSE} = 800mV

$$Rset = 8 \cdot (75 / 0.8) = 750\Omega$$

This formula is not valid for long, unterminated, or improperly terminated cables.

This formula should be considered as a starting point, and actual swing values may vary based on layout. Also, for large output swings (>1040mV), smaller Rset values may be required in order to achieve the desired output swing level at HD and 3G data rates.

Table 4-5: Typical RSET Values

Output Swing (mV)	RSET (Ω)
1800*	332
800	750
500	1210

*NOTE: In order to generate output swings greater than 1040mV, VCC_TERM must be connected to a 5V supply.

4.7 Output Return Loss Measurement

The GS2988 has a feature which allows users to measure ORL reliably while the device is still powered. The device can be put into a BALANCE mode which prevents the outputs from toggling while the device is powered on, allowing the ORL to be measured while the device is still powered.

When $\overline{EQ_EN}$ is LOW while SD/\overline{HD} is HIGH, the device goes into BALANCE mode. This mode is used during ORL measurement, disabling the AC signal path of the device without powering it down. When in BALANCE mode, the device produces equal pull-down currents in both differential shoulders of the serial data differential output, effectively stopping the output at the output common mode voltage level. Gennum recommends using BALANCE mode when measuring ORL with 2.5V termination voltage.

5. Application Information

5.1 PCB Layout

Special attention must be paid to component layout when designing serial digital interfaces for HDTV.

An FR-4 dielectric can be used, however, controlled impedance transmission lines are required for PCB traces longer than approximately 1cm. Note the following PCB artwork features used to optimize performance:

- The PCB trace width for HD rate signals is closely matched to SMT component width to minimize reflections due to changes in trace impedance
- The PCB ground plane is removed under the GS2988 output components to minimize parasitic capacitance (NOTE: care should be taken, as removing too much of the plane will make the system susceptible to EMI)
- The PCB ground plane is removed under the GS2988 RSET pin and resistor to minimize parasitic capacitance. The RSET resistor should be directly connected to the VCC plane
- Input and output BNC connectors are surface mounted in-line to eliminate a transmission line stub caused by a BNC mounting via high-speed traces
- High-speed traces are curved to minimize impedance variations due to change of PCB trace width

NOTE: For more recommendations on Trace Lengths, ORL Inductor Values and other PCB Layout Considerations, please refer to Gennum's GS2989 Design Guide (Doc ID 52070).

5.2 Typical Application Circuit

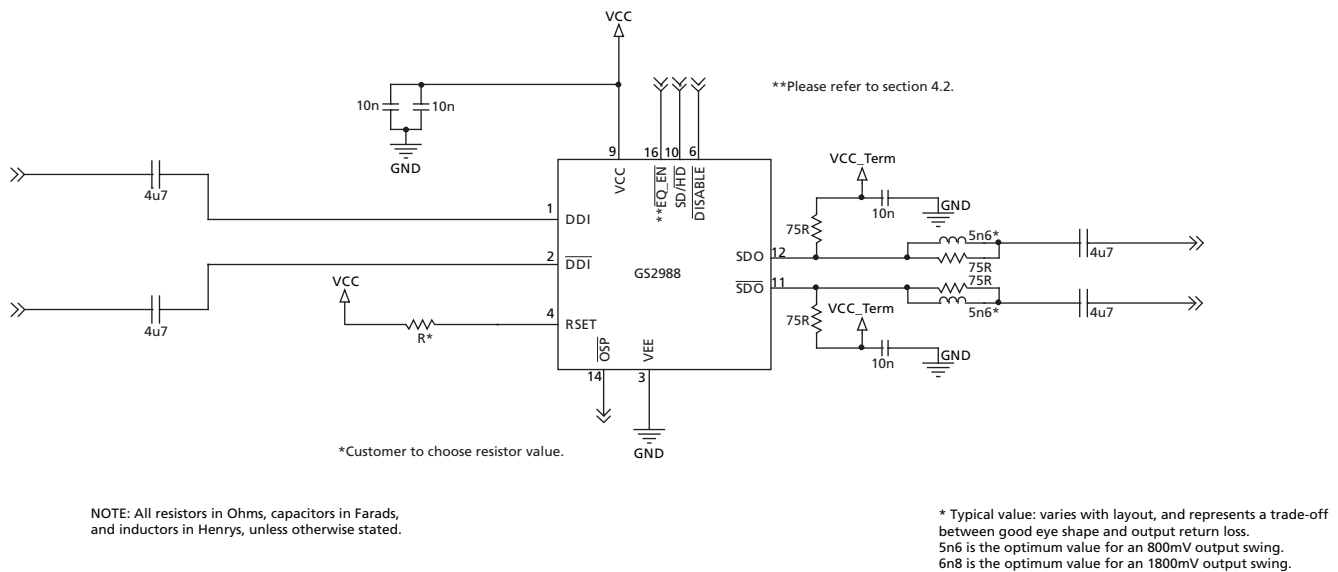
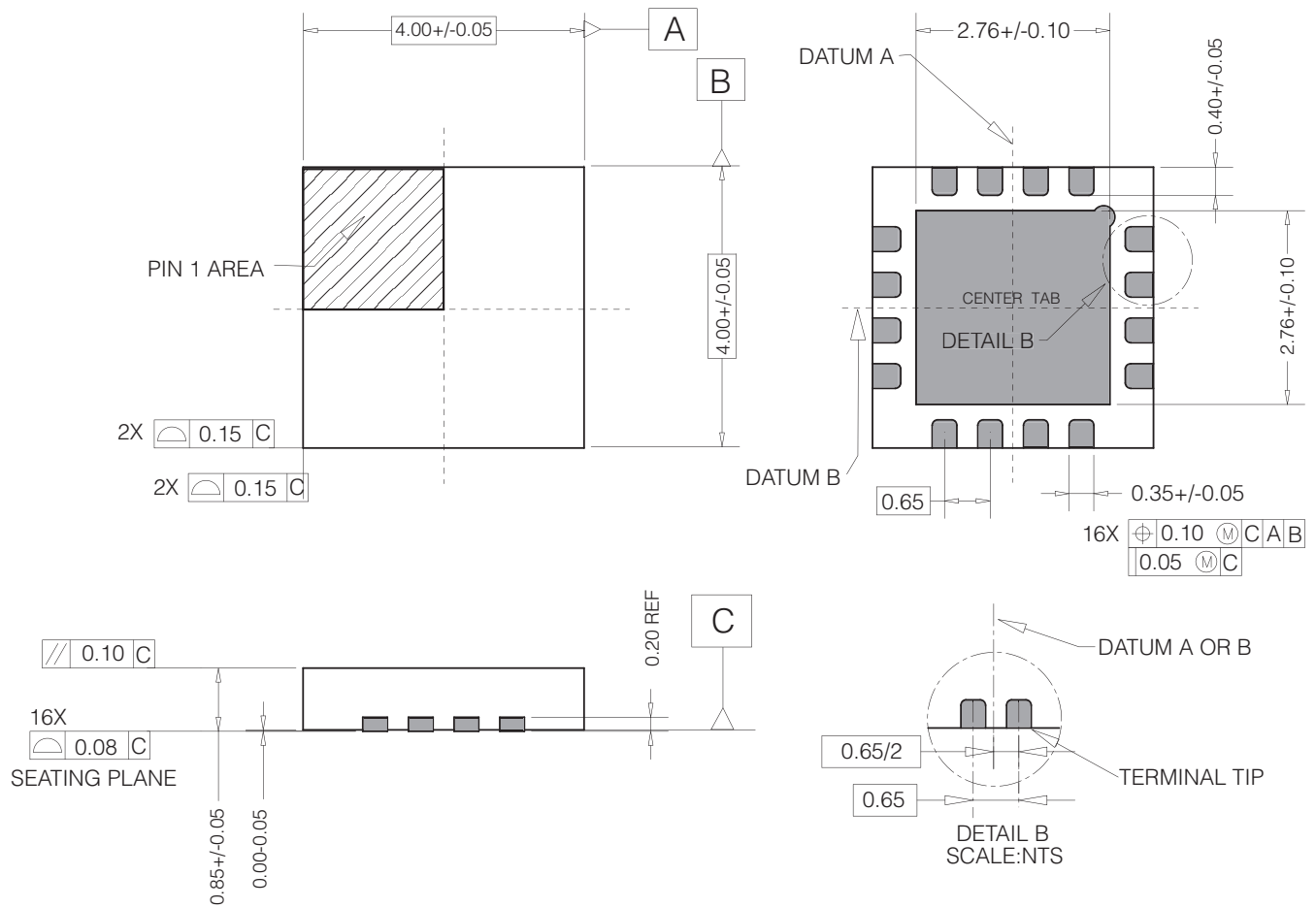

Figure 5-1: Typical Application Circuit

6. Package & Ordering Information

6.1 Package Dimensions



6.2 Recommended PCB Footprint

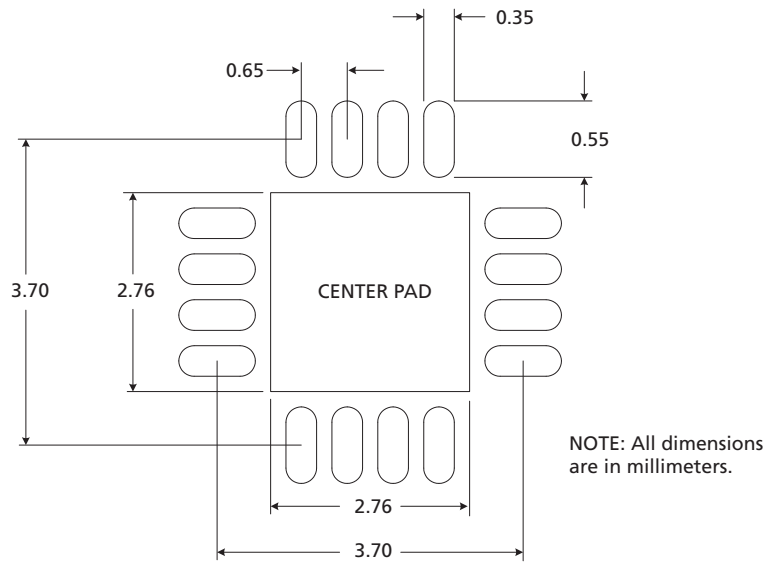

The Center Pad should be connected to the most negative power supply plane (VEE) by a minimum of 5 vias.

NOTE: Suggested dimensions only. Final dimensions should conform to customer design rules and process optimizations.

6.3 Packaging Data

Parameter	Value
Package type / dimensions / pad pitch	16-pin QFN / 4mm x 4mm / 0.65mm
Package Drawing Reference	JEDEC M0220
Moisture Sensitivity Level	3
Junction to Case Thermal Resistance, θ_{j-c}	31.0°C/W
Junction to Air Thermal Resistance, θ_{j-a} (at zero airflow)	43.8°C/W
Psi, Ψ	11.0°C/W
Pb-free and RoHS compliant, Halogen-free	Yes

6.4 Solder Reflow Profiles

The device is manufactured with Matte-Sn terminations and is compatible with both standard eutectic and Pb-free solder reflow profiles. MSL qualification was performed using the maximum Pb-free reflow profile shown in Figure 6-1.

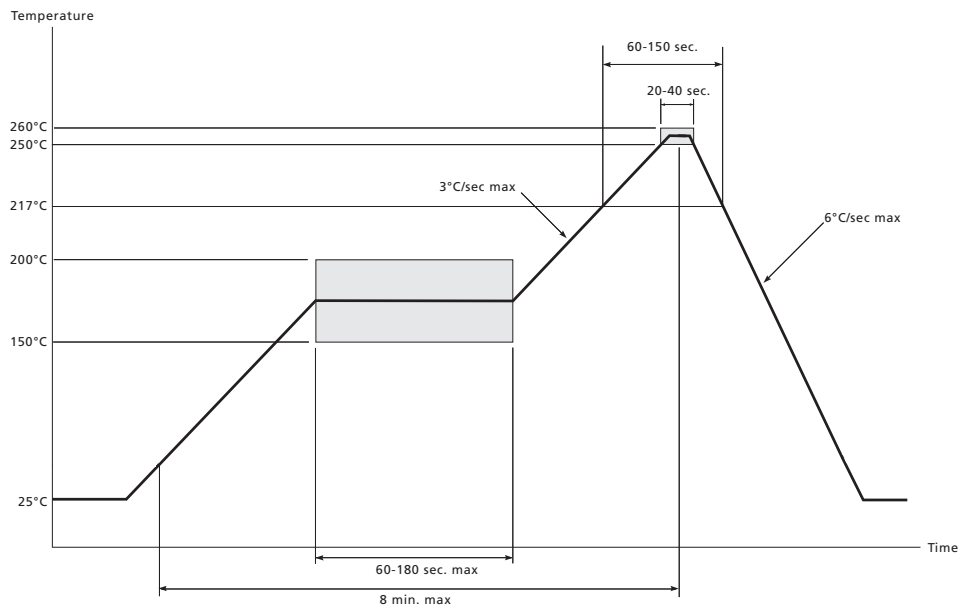
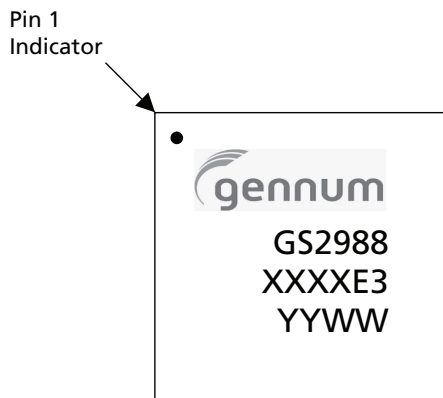

Figure 6-1: Maximum Pb-free Solder Reflow Profile (Preferred)

6.5 Marking Diagram



Instructions:	
GS2988	Package Mark
XXXX	Last 4 digits (excluding decimal) of SAP Batch Assembly (FIN) as listed on Packing Slip
E3	Pb-free & Green indicator
YYWW	Date Code

6.6 Ordering Information

	Part Number	Package	Temperature Range	
	GS2988	GS2988-INE3	16-pin QFN	-40°C to 85°C
	GS2988	GS2988-INTE3	16-pin QFN 250pc Reel	-40°C to 85°C
	GS2988	GS2988-INTE3Z	16-pin QFN 2,500pc Reel	-40°C to 85°C

DOCUMENT IDENTIFICATION DATA SHEET

The product is in production. Gennum reserves the right to make changes to the product at any time without notice to improve reliability, function or design, in order to provide the best product possible.

CAUTION

ELECTROSTATIC SENSITIVE DEVICES

DO NOT OPEN PACKAGES OR HANDLE EXCEPT AT A
STATIC-FREE WORKSTATION



GENNUM CORPORATE HEADQUARTERS

4281 Harvester Road, Burlington, Ontario L7L 5M4 Canada

Phone: +1 (905) 632-2996

E-mail: corporate@gennum.com

Fax: +1 (905) 632-2055

www.gennum.com

OTTAWA

232 Herzberg Road, Suite 101
Kanata, Ontario K2K 2A1
Canada

Phone: +1 (613) 270-0458

Fax: +1 (613) 270-0429

CALGARY

Suite 320, 3553 31st St. N.W.
Calgary, Alberta T2L 2K7
Canada

Phone: +1 (403) 284-2672

Fax: +1 (905) 632-2055

UNITED KINGDOM

South Building, Walden Court
Parsonage Lane,
Bishop's Stortford Hertfordshire, CM23 5DB
United Kingdom

Phone: +44 1279 714170

Fax: +44 1279 714171

INDIA

#208(A), Nirmala Plaza,
Airport Road, Forest Park Square
Bhubaneswar 751009
India

Phone: +91 (674) 65304815

Fax: +91 (674) 259-5733

SNOWBUSH IP - A DIVISION OF GENNUM

439 University Ave. Suite 1700
Toronto, Ontario M5G 1Y8
Canada

Phone: +1 (416) 925-5643

Fax: +1 (416) 925-0581

E-mail: sales@snowbush.com

Web Site: <http://www.snowbush.com>

MEXICO

Venustiano Carranza 122 Int. 1
Centro, Aguascalientes
Mexico CP 20000

Phone: +1 (416) 848-0328

JAPAN KK

Shinjuku Green Tower Building 27F
6-14-1, Nishi Shinjuku
Shinjuku-ku, Tokyo, 160-0023
Japan

Phone: +81 (03) 3349-5501

Fax: +81 (03) 3349-5505

E-mail: gennum-japan@gennum.com

Web Site: <http://www.gennum.co.jp>

TAIWAN

6F-4, No.51, Sec.2, Keelung Rd.
Sinyi District, Taipei City 11502
Taiwan R.O.C.

Phone: (886) 2-8732-8879

Fax: (886) 2-8732-8870

E-mail: gennum-taiwan@gennum.com

GERMANY

Gennum Canada Limited
Niederlassung Deutschland
München, Germany

Phone: +49 89 309040 290

Fax: +49 89 309040 293

E-mail: gennum-germany@gennum.com

NORTH AMERICA WESTERN REGION

691 South Milpitas Blvd., Suite #200
Milpitas, CA 95035
United States

Phone: +1 (408) 934-1301

Fax: +1 (408) 934-1029

E-mail: naw_sales@gennum.com

NORTH AMERICA EASTERN REGION

4281 Harvester Road
Burlington, Ontario L7L 5M4
Canada

Phone: +1 (905) 632-2996

Fax: +1 (905) 632-2055

E-mail: nae_sales@gennum.com

Gennum Corporation assumes no liability for any errors or omissions in this document, or for the use of the circuits or devices described herein. The sale of the circuit or device described herein does not imply any patent license, and Gennum makes no representation that the circuit or device is free from patent infringement.

All other trademarks mentioned are the properties of their respective owners.

GENNUM and the Gennum logo are registered trademarks of Gennum Corporation.

© Copyright 2009 Gennum Corporation. All rights reserved.

www.gennum.com