



Chipsmall Limited consists of a professional team with an average of over 10 year of expertise in the distribution of electronic components. Based in Hongkong, we have already established firm and mutual-benefit business relationships with customers from,Europe,America and south Asia,supplying obsolete and hard-to-find components to meet their specific needs.

With the principle of “Quality Parts,Customers Priority,Honest Operation,and Considerate Service”,our business mainly focus on the distribution of electronic components. Line cards we deal with include Microchip,ALPS,ROHM,Xilinx,Pulse,ON,Everlight and Freescale. Main products comprise IC,Modules,Potentiometer,IC Socket,Relay,Connector.Our parts cover such applications as commercial,industrial, and automotives areas.

We are looking forward to setting up business relationship with you and hope to provide you with the best service and solution. Let us make a better world for our industry!



## Contact us

Tel: +86-755-8981 8866 Fax: +86-755-8427 6832

Email & Skype: info@chipsmall.com Web: www.chipsmall.com

Address: A1208, Overseas Decoration Building, #122 Zhenhua RD., Futian, Shenzhen, China



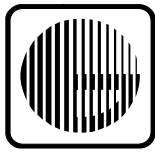

FEATURES

- **automatic cable equalization**
- **typically greater than 300 m of high quality cable at 270 Mb/s**
- **typically 300 m of high quality cable at 360 Mb/s**
- **drop in replacement for GS9004C**
- **capability to drive 50 Ω loads (to  $V_{TT}$ )**
- **fully compatible with SMPTE 259M and operational to 400 Mb/s**
- **signal strength indicator**
- **output 'eye' monitor**
- **14 pin SOIC packaging**
- **single +5 or -5 volt power supply operation**
- **Pb-free and Green**

APPLICATIONS

- Front-end cable equalization for digital video systems
- Input equalization for serial digital distribution amplifiers, routers, production switchers and other receiving equipment

ORDERING INFORMATION

Part Number	Package Type	Temperature Range	Pb-Free and Green
GS9004DCKB	14 pin SOIC	0°C to 70°C	No
GS9004DCTB	14 pin SOIC Tape	0°C to 70°C	No
GS9004DCKBE3	14 pin SOIC	0°C to 70°C	Yes

DEVICE DESCRIPTION

The Genum GS9004D is an improved monolithic automatic cable equalizer developed for SMPTE/EBU scrambled NRZI Serial Digital Video signals.

While there are no plans to discontinue the GS9004D, Genum has developed a successor product with improved features and performance called the GS9024. The GS9024 is recommended for new designs.

This device features DC restoration to pass the Pathological Test Signals and fully automatic equalization in order to meet the SMPTE 259M Serial Interface Standard. The DATA and  $\overline{\text{DATA}}$  outputs typically deliver 800 mV (p-p) equalized signals into 50 Ω loads (to  $V_{TT}$ ). These signals can be used to feed cable driver circuits for Serial Distribution Amplifier applications.

This device also incorporates an analog signal strength indicator (SSI) which provides a 0.5 V to 0 V output relative to  $V_{CC}$ , indicating the amount of equalization being applied to the signal.

The GS9004D features an OUTPUT 'EYE' MONITOR (OEM), which allows verification of signal integrity after equalization, prior to reslicing. Operating with a single +5 or -5 volt supply, the GS9004D typically draws 52 mA of current.

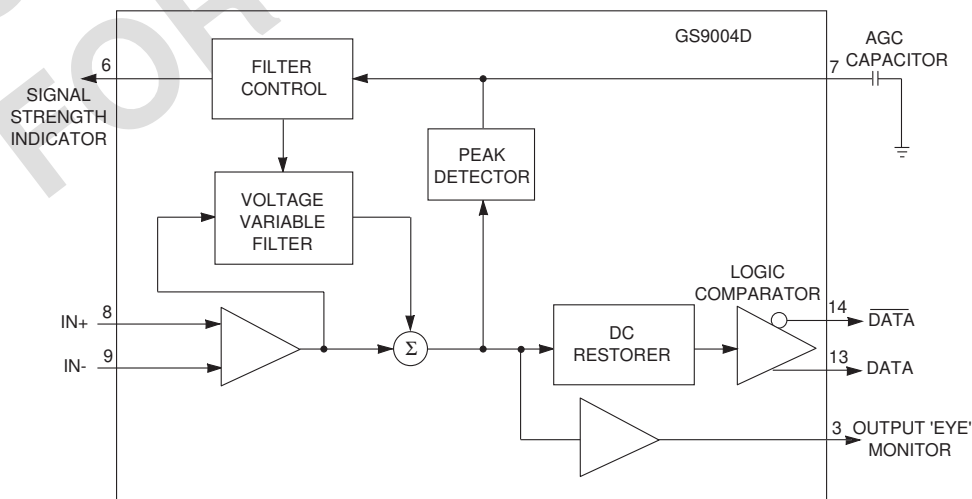

FUNCTIONAL BLOCK DIAGRAM

**ABSOLUTE MAXIMUM RATINGS**

PARAMETER	VALUE
Supply Voltage ( $V_S$ )	5.5 V
Input Voltage Range (any input)	$V_{CC}+0.5$ to $V_{EE} -0.5$ V
DC Input Current (any one input)	10 mA
Power Dissipation	500 mW
Operating Temperature Range	$0^{\circ}\text{C} \leq T_A \leq 70^{\circ}\text{C}$
Storage Temperature Range	$-65^{\circ}\text{C} \leq T_S \leq 150^{\circ}\text{C}$
Lead Temperature (soldering, 10 sec)	$260^{\circ}\text{C}$

**GS9004D  
PIN CONNECTIONS**

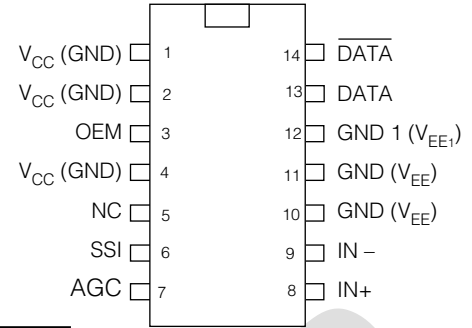

**PIN DESCRIPTIONS** (I = INPUT, O = OUTPUT, S = SUPPLY function)

PIN NO.	SYMBOL	I/O	DESCRIPTION
1	$V_{CC}$ (GND)	S	Most positive supply voltage (ECL outputs)
2	$V_{CC}$ (GND)	S	Most positive supply voltage (DC Restore/Eye Monitor)
3	OEM	O	Output 'Eye' Monitor
4	$V_{CC}$ (GND)	S	Most positive supply voltage (Equalizer)
5	NC		No Connection
6	SSI	O	Signal Strength Indicator
7	AGC	I	AGC capacitor connection
8	IN+	I	Non-inverting signal
9	IN-	I	Inverting signal
10	$\text{GND}(V_{EE})$	S	Most negative supply voltage
11	$\text{GND}(V_{EE})$	S	Most negative supply voltage
12	$\text{GND}1(V_{EE1})$	S	Most negative supply voltage for EYE MONITOR
13	DATA	O	DATA (true)
14	$\overline{\text{DATA}}$	O	DATA (inverse)

**GS9004D DC ELECTRICAL CHARACTERISTICS** Conditions:  $V_S = 5$  V,  $T_A = 0^{\circ}$  to  $70^{\circ}\text{C}$ ,  $R_L = 100 \Omega$ , to  $(V_{CC} - 2)$  volts, unless otherwise shown.

PARAMETER	SYMBOL	CONDITIONS	MIN	TYP	MAX	UNITS	NOTES
Supply Voltage	$V_S$	Operating Range	4.75	5.0	5.25	V	
Power Consumption	$P_D$		-	285	360	mW	
		With MONITOR active	-	330	415	mW	
Supply Current	$I_S$		-	52	72	mA	
		With MONITOR active	-	60	83	mA	
Serial Data Output - High - Low	$V_{OH \text{ MIN}}$	$T_A = 25^{\circ}\text{C}$	-1.025	-	-0.88	V	with respect to $V_{CC}$
	$V_{OL \text{ MAX}}$	$T_A = 25^{\circ}\text{C}$	-1.8	-	-1.6	V	with respect to $V_{CC}$

**GS9004D AC ELECTRICAL CHARACTERISTICS** Conditions:  $V_S = 5$  V,  $T_A = 0^{\circ}$  to  $70^{\circ}\text{C}$ ,  $R_L = 100 \Omega$ , to  $(V_{CC} - 2)$  volts, unless otherwise shown

PARAMETER	SYMBOL	CONDITIONS	MIN	TYP	MAX	UNITS	NOTES
Output Signal Swing	$V_O$	$T_A = 25^{\circ}\text{C}$	700	800	900	mV	
Input Resistance(IN+, IN-)	$R_{IN}$		4k	5k	-	$\Omega$	see fig. 5
Input Capacitance(IN+, IN-)	$C_{IN}$	$T_A = 25^{\circ}\text{C}$	-	1.3	-	pF	see fig. 5
Output 'Eye' Monitor	$V_{OEM}$	$R_L = 50\Omega$ , To $V_{CC}$	-	40	-	mV p-p	
Signal Strength Output	$V_{SS}$		4.4	-	5	V	
GS9004C GAIN	$A_V$	$T_A = 25^{\circ}\text{C}$ $f = 135$ MHz	30	33	-	dB	
JITTER (Added) 270Mb/s	$t_j$	$T_A = 25^{\circ}\text{C}$ , 300m of 8281 cable.	-	600	-	ps p-p	Test setup 1



## GS9004D CABLE EQUALIZER - DETAILED DEVICE DESCRIPTION

The GS9004D Cable Equalizer is a bipolar integrated circuit used to equalize SMPTE 259M signals from a co-axial cable. The device is implemented as a fourteen pin SOIC, powered from a single five volt supply. With an operating frequency up to 400 Mb/s, the equalizer consumes about 285 mW of power.

The Serial Digital signal is connected to the input (pins 8, 9) either differentially or single ended with the unused input being decoupled. The equalized signal is generated by passing the cable signal through a voltage variable filter having a characteristic which closely matches the inverse cable loss characteristic. Additionally, the variation of the filter characteristic with control voltage is designed to imitate the variation of the inverse cable loss characteristic as the cable length is varied.

The amplitude of the equalized signal is monitored by a peak detector circuit which produces an output current with a polarity corresponding to the difference between the desired peak signal level and the actual peak signal level.

This output is integrated by an external AGC filter capacitor (AGC CAP pin 7), providing a steady control voltage for the voltage variable filter.

A separate signal strength indicator output, (SSI pin 6), proportional to the amount of AGC, is also provided. As the filter characteristic is varied automatically by the application of negative feedback, the amplitude of the equalized signal is kept at a constant level which is representative of the original amplitude at the transmitter.

The equalized signal is then DC restored, effectively restoring the logic threshold of the equalized signal to its correct level irrespective of shifts due to AC coupling.

As the final stage of signal conditioning, a comparator converts the analog output of the DC restorer to a regenerated digital output signal having pseudo-ECL voltage levels. These outputs, DATA and DATA, are available from pins 13 and 14 respectively.

An OUTPUT 'EYE' MONITOR (pin 3) allows verification of signal integrity after equalization, prior to reslicing.

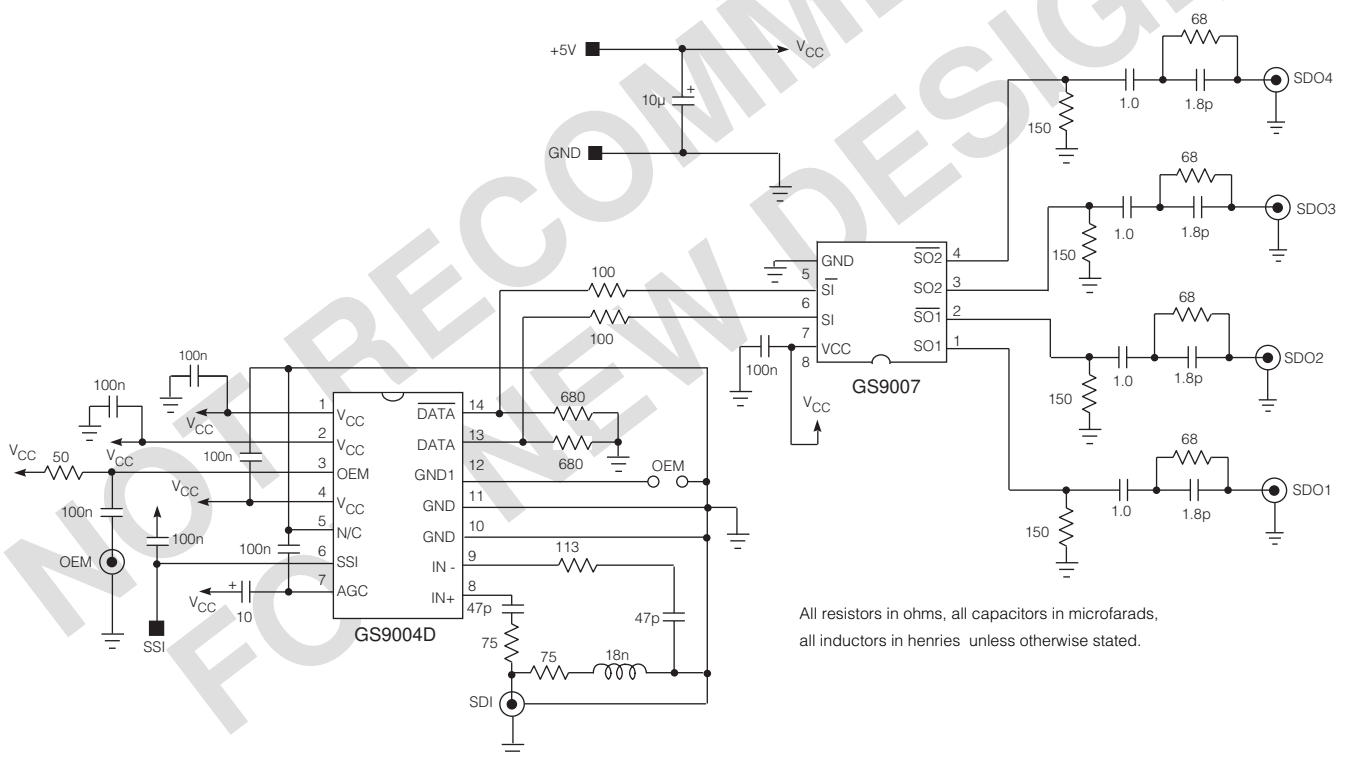

Fig. 1 Test Circuit

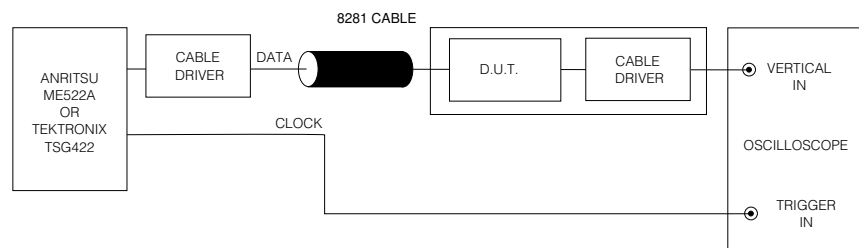

Fig. 2 Test Set-up 1

TYPICAL PERFORMANCE CURVES (unless otherwise shown  $V_S = 5V$ ,  $T_A = 25^\circ C$ )

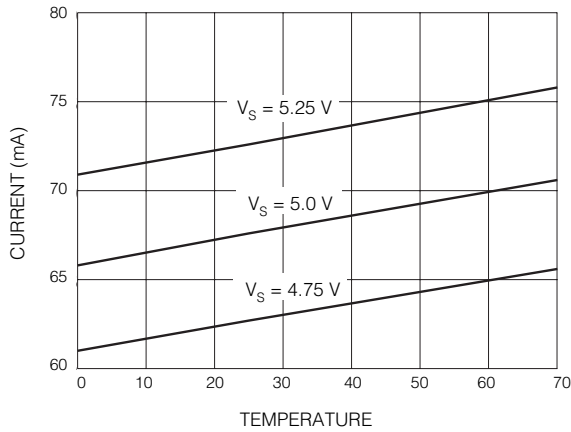

Fig. 3 Supply Current vs Temperature

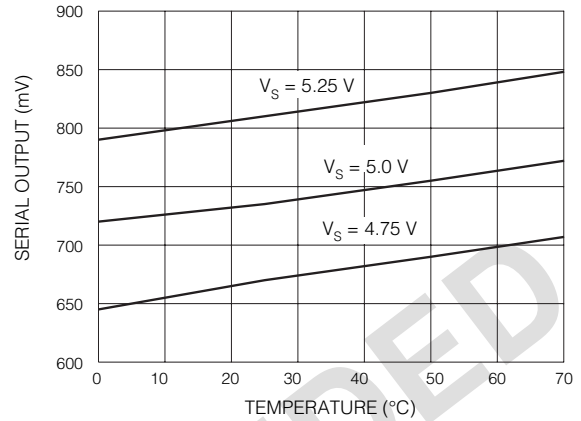

Fig. 4 Data and Data Output Voltage vs Temperature

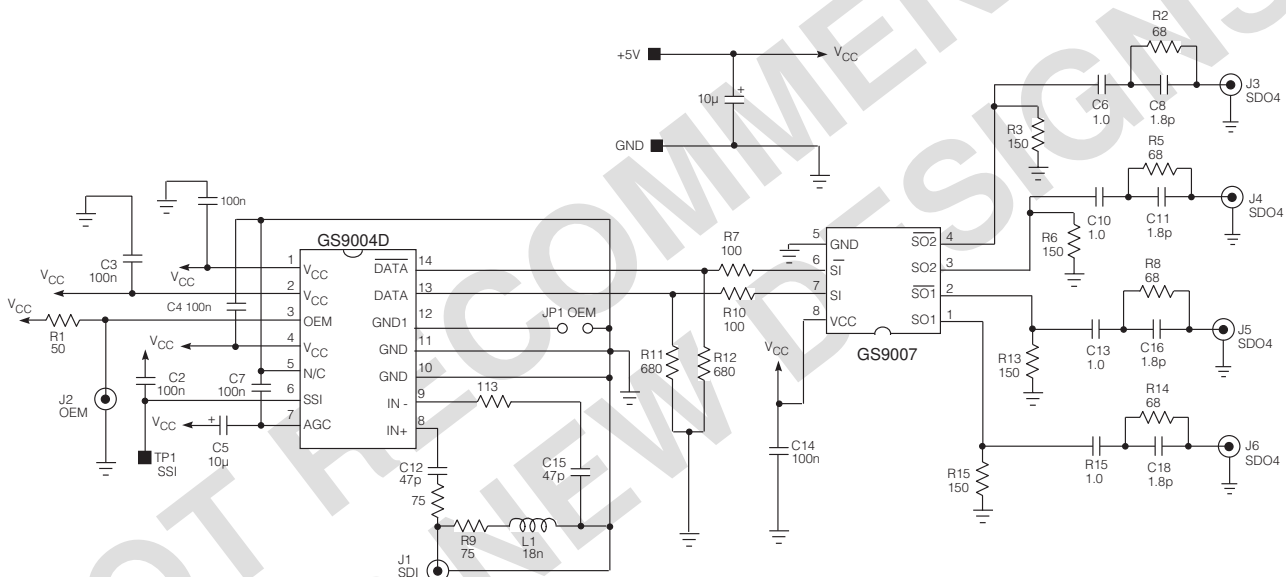

Fig. 5 Typical Application Circuit

All resistors in ohms, all capacitors in microfarads unless otherwise stated.

**CAUTION**  
ELECTROSTATIC SENSITIVE DEVICES  
DO NOT OPEN PACKAGES OR HANDLE EXCEPT AT A STATIC-FREE WORKSTATION

**DOCUMENT IDENTIFICATION: DATA SHEET**  
The product is in production. Gennum reserves the right to make changes at any time to improve reliability, function or design, in order to provide the best product possible.

**REVISION NOTES:**  
New document.  
*For latest product information, visit [www.gennum.com](http://www.gennum.com)*

**GENNUM CORPORATION**  
MAILING ADDRESS:  
P.O. Box 489, Stn. A, Burlington, Ontario, Canada L7R 3Y3  
Tel. +1 (905) 632-2996 Fax +1 (905) 632-2814  
SHIPPING ADDRESS:  
970 Fraser Drive, Burlington, Ontario, Canada L7L 5P5

**GENNUM JAPAN CORPORATION**  
Shinjuku Green Tower Building 27F 6-14-1, Nishi Shinjuku Shinjuku-ku,  
Tokyo 160-0023 Japan Tel: +81 (03) 3349-5501 Fax: +81 (03) 3349-5505  
**GENNUM UK LIMITED**  
25 Long Garden Walk Farnham, Surrey, England GU9 7HX  
Tel: +44 (0) 1252 747000 Fax: +44 (0) 1252 726523