



Chipsmall Limited consists of a professional team with an average of over 10 year of expertise in the distribution of electronic components. Based in Hongkong, we have already established firm and mutual-benefit business relationships with customers from,Europe,America and south Asia,supplying obsolete and hard-to-find components to meet their specific needs.

With the principle of "Quality Parts,Customers Priority,Honest Operation,and Considerate Service",our business mainly focus on the distribution of electronic components. Line cards we deal with include Microchip,ALPS,ROHM,Xilinx,Pulse,ON,Everlight and Freescale. Main products comprise IC,Modules,Potentiometer,IC Socket,Relay,Connector.Our parts cover such applications as commercial,industrial, and automotives areas.

We are looking forward to setting up business relationship with you and hope to provide you with the best service and solution. Let us make a better world for our industry!



## Contact us

Tel: +86-755-8981 8866 Fax: +86-755-8427 6832

Email & Skype: info@chipsmall.com Web: www.chipsmall.com

Address: A1208, Overseas Decoration Building, #122 Zhenhua RD., Futian, Shenzhen, China



# GSK-10

## Touch Control Switch Kit

LEVEL 1

### Technical data

- Power supply : 12VDC.
- Electric current consumption : 45mA. max.
- Maximum load : 10A@125VAC and 5A@220VAC
- IC board dimension : 3.17 in x 1.56 in.

### How does it work

The functionality of this circuit base mainly on the flip-flop action of TR3 and TR4. There are two options of the application i.e. Purely touch switch (on-off) and semi-action. The explanation will begin with.

Purely touch switch (on-off) : (J is left opened).

When the circuit is first activated (by supplying the voltage) the LED remain dark. By touching the T terminal TR1 and TR2 start to conduct the current which make TR3 inaction while TR4 on the contrary begin to let the current pass through. The LED finally begin to grow. On the contrary, if the T terminal is touched again the flip-flop action of TR1 and TR2 make TR3 action while put TR4 in standby. The LED them give no light.

Semi-action : (J is connected).

In this mode, the T terminal must have a constant contact with the finger in order to turn the LED on. As soon as the T terminal lost contact with the finger the light from LED goes out.

The explanation of why LED is on while T terminal is touched can be found in purely touch situation. When T terminal left open (no finger on T) both TR1 and TR2 are in stand by mode TR3 then begin to conduct the current which make TR4 into sleep mode. When this happen LED then shows no light. This logic is possible because of J terminal is connected.

### Circuit Assembly

The assembly of components is shown in Fig. 2. For good looking and easy assembly, the shorter components should be first installed - starting with low resistant components and then the higher. An important thing is that diodes, electrolyte capacitors, and transistors shall be carefully assembled before mounting them onto their right anode/cathode of the IC board otherwise it might cause damage to the components or the circuit. Configuration of the anode and the cathode is shown in Fig 3. Use the soldering iron/gun not exceeding 40 watts and the solder of tin-lead 60:40 with flux within. Recheck the correctness of installation after soldering. In case of wrong position, just use lead absorber or lead extractor wire to avoid probable damage to the IC.

### Testing

Do not connecting J to each other. Connect the power supply 12VDC to circuit. Touching T sensor 1 time, LED displays and relay works. Taking supply off and connecting J together. Connect power supply again. Now LED does not display. Touching T sensor, LED and relay is start working and will stop when touching T sensor again. Selecting desired function types, if requires 1 touch start and 1 touch stop, do not connecting J together. If requires touching switch on and untouched for switch off, connecting J together.

## Figure 1. Touch Switch (On/Off) Circuit

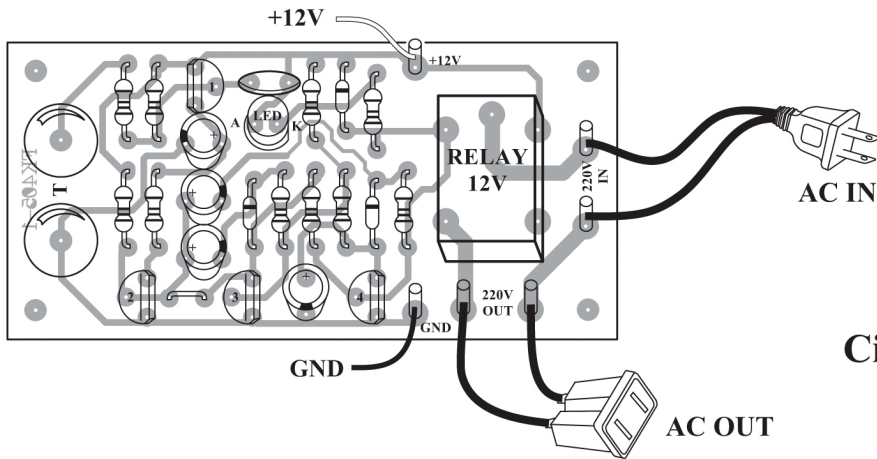
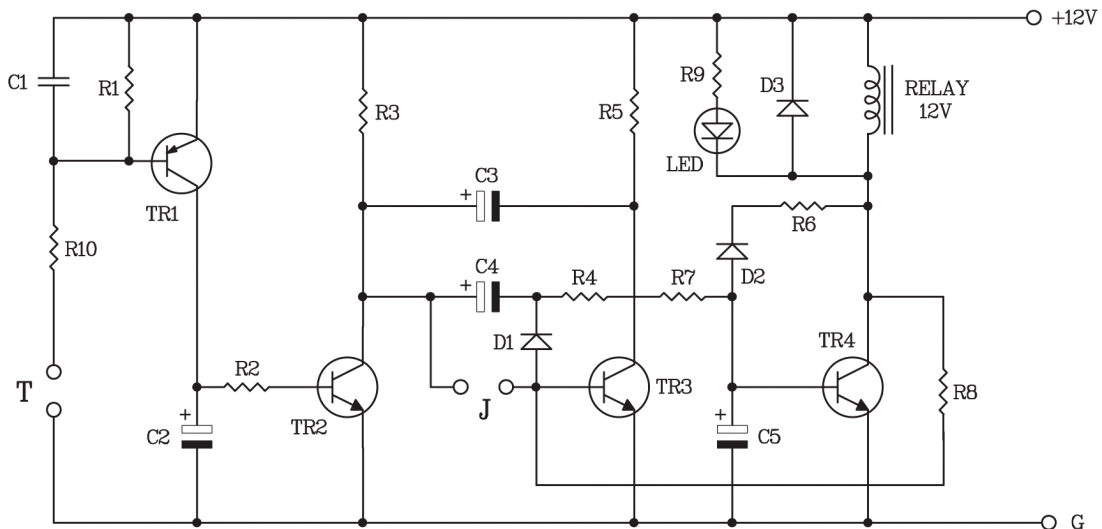

## Figure 2. Circuit Assembling

NO.1

## Figure 3. Installing the Components

