



Chipsmall Limited consists of a professional team with an average of over 10 year of expertise in the distribution of electronic components. Based in Hongkong, we have already established firm and mutual-benefit business relationships with customers from,Europe,America and south Asia,supplying obsolete and hard-to-find components to meet their specific needs.

With the principle of "Quality Parts,Customers Priority,Honest Operation,and Considerate Service",our business mainly focus on the distribution of electronic components. Line cards we deal with include Microchip,ALPS,ROHM,Xilinx,Pulse,ON,Everlight and Freescale. Main products comprise IC,Modules,Potentiometer,IC Socket,Relay,Connector.Our parts cover such applications as commercial,industrial, and automotives areas.

We are looking forward to setting up business relationship with you and hope to provide you with the best service and solution. Let us make a better world for our industry!



Contact us

Tel: +86-755-8981 8866 Fax: +86-755-8427 6832

Email & Skype: info@chipsmall.com Web: www.chipsmall.com

Address: A1208, Overseas Decoration Building, #122 Zhenhua RD., Futian, Shenzhen, China



Solar Guide Light Model GSK-1004

This circuit illuminates 5 LED's when there is not sufficient sunlight for the solar panel to charge batteries. The LED's will automatically turn on and draw voltage from the batteries when the solar panel can no longer convert sunlight to DC voltage.

Technical Specifications

- Power Source: 3 rechargeable double AA batteries (not included)
- Power consumption: 2.5 mA (standby), 80 mA (working)
- Recharging circuit: Built in solar panel
- Solar panel: 4 VDC, 60 mA
- Intensity adjust: potentiometer
- PCB dimensions: 2.39 x 1.70 inches

Operating Principles

This circuit consists of two parts, the charger and sensor. When the solar panel is facing sunlight it will convert the sun's energy to DC voltage and run through transistors 1 and 3 charging the rechargeable batteries. The sensors are activated when the photo-transistor (solar panel) does not receive sufficient sunlight the internal resistance becomes greater triggering transistor 5 to light all LED's. Illumination intensity is controlled through transistor 2 and variable resistor 1.

Circuit Assembly

Please refer to Figures 1, 2, and 3 for aid in component placement. It is recommended to start with lower components i.e. diodes, resistors, electrolyte capacitors, and transistors. Be careful to check polarity before soldering. If a problem is detected it is best to use a desoldering pump or desoldering braids to remove component. This will minimize potential damage to the printed circuit board.

Testing

Turn the solar panel to receive the maximum sunlight. The LED's should be off as the circuit is in the recharging cycle. Cover or remove the solar panel from the sunlight and all 5 LED's should light. Set intensity by adjusting variable resistor 1.

Note

This solar panel will not convert fluorescent light to DC voltage.

Figure 1 Installing components

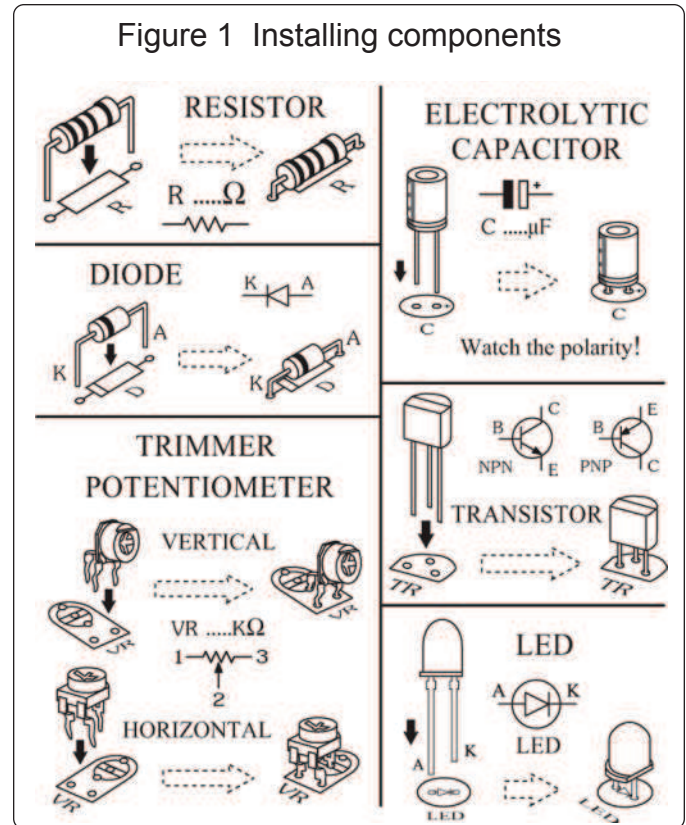

Special handling instruction

Extra care must be taken to ensure proper installation of solar panel to PCB. Server damage may occur to the solar panel if the positive and negative poles are short circuited when soldering.

Troubleshooting

This circuit has only a few components, the main cause of problems will come from misplaced components or faulty soldering. Utilize figures 2 and 3 to ensure proper placement/polarity and then check solder points for connectivity.

Accessories

Use GSB-03 (sold separately) to house the PCB and batteries.

Figure 2 SOLAR NIGHT 5 LED Circuit

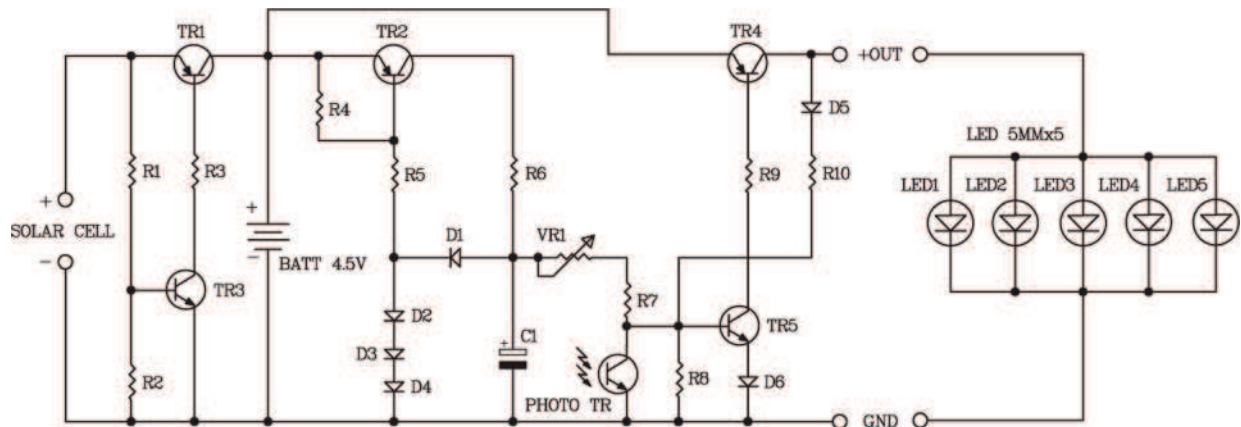
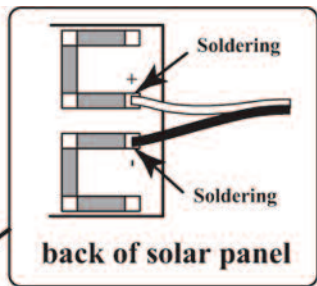
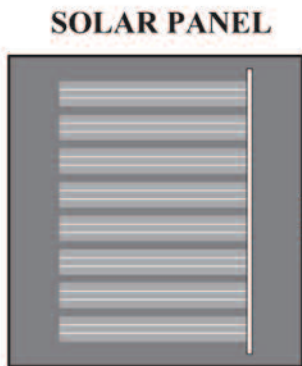
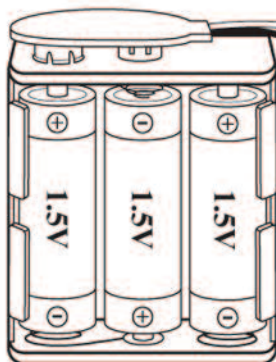
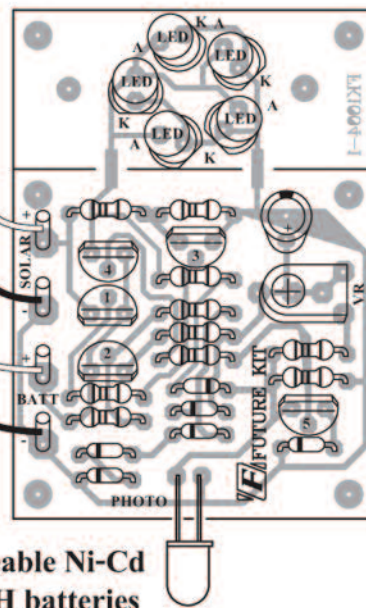

Figure 3 Connecting circuits



GSK-1004



Rechargeable Ni-Cd
or NI-MH batteries
size AAx3 pcs.

Resistors

R1, R2	10 kΩ	brown – black – orange - gold
R3	5 kΩ	green – black – red - gold
R4, R5	2 kΩ	red – black – red - gold
R6	1 kΩ	brown – black – red - gold
R7, R8, R10	100 kΩ	brown – black – yellow - gold
R9	500 Ω	green – black – brown – gold

Potentiometer

VR1 100 kΩ or 104

Electrolytic Capacitor

C1 10 μF

Transistors

TR1, TR2, TR4 C9012
TR3, TR5 C458, C828, C945, C1815

Diodes

D1-D6 1N4148