



Chipsmall Limited consists of a professional team with an average of over 10 year of expertise in the distribution of electronic components. Based in Hongkong, we have already established firm and mutual-benefit business relationships with customers from,Europe,America and south Asia,supplying obsolete and hard-to-find components to meet their specific needs.

With the principle of "Quality Parts,Customers Priority,Honest Operation,and Considerate Service",our business mainly focus on the distribution of electronic components. Line cards we deal with include Microchip,ALPS,ROHM,Xilinx,Pulse,ON,Everlight and Freescale. Main products comprise IC,Modules,Potentiometer,IC Socket,Relay,Connector.Our parts cover such applications as commercial,industrial, and automotives areas.

We are looking forward to setting up business relationship with you and hope to provide you with the best service and solution. Let us make a better world for our industry!



Contact us

Tel: +86-755-8981 8866 Fax: +86-755-8427 6832

Email & Skype: info@chipsmall.com Web: www.chipsmall.com

Address: A1208, Overseas Decoration Building, #122 Zhenhua RD., Futian, Shenzhen, China



Water Resistance Checker (basic) Model GSK-944

This checker utilizes resistance to measure dissolved solids in water. The more resistance, the less conductive the water; as resistance levels lessens the materials that conduct electricity are elevated. Results are displayed by a series of (8) LED's.

Technical Specifications

- Power source: 9 VDC
- LED resistance level indicators: 7
- LED on/off indicator: 1
- Level adjustment: 3 levels
- PCB dimensions: 2.78 x 1.79 in.

Operating Principles

The more resistance in water the less dissolved solids, such as minerals, are present. Conversely, as resistance decreases the level of conductive material in the water increases. A series of (green, yellow, and red) LED's indicate the level of resistance (Green – higher through Red – lowest) the more LED's lit the less resistance. There are 3 switchable levels (see Figure 1 resistance table).

Circuit Assembly

Please refer to Figures 1, 2, and 3 for aid in component placement. It is recommended to start with lower components i.e. diodes, resistors, electrolyte capacitors, and transistors. Be careful to check polarity before soldering. If a problem is detected it is best too use a desoldering pump or desoldering braids to remove component. This will minimize potential damage to the printed circuit board.

Testing

Connect the battery to provide power to the circuit. The LED power light will come on. Slide switch "SW" to position "1." Insert probe into water source, LED 1 through LED 8 will display level of resistance in water source.

Troubleshooting

The main cause of problems will come from misplaced components or faulty soldering. Utilize Figures 1, 2 and 3 to ensure proper placement, polarity and then check solder points for connectivity.

Figure 1 Water Checker Circuit

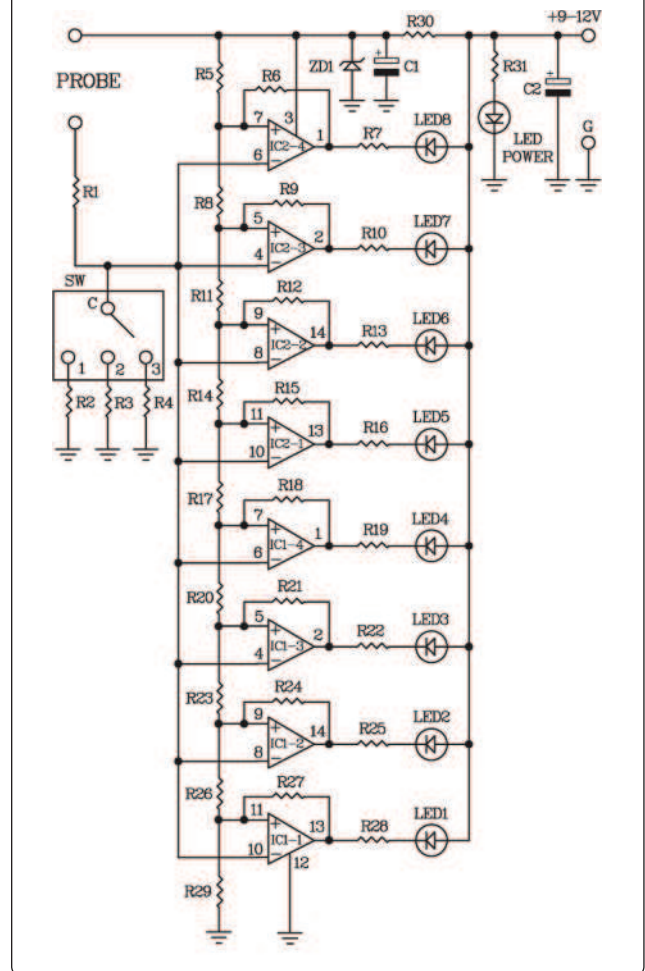

Accessories

Use GSB-03 (sold separately) to house the PCB and batteries.

Figure 2 Connecting Circuits

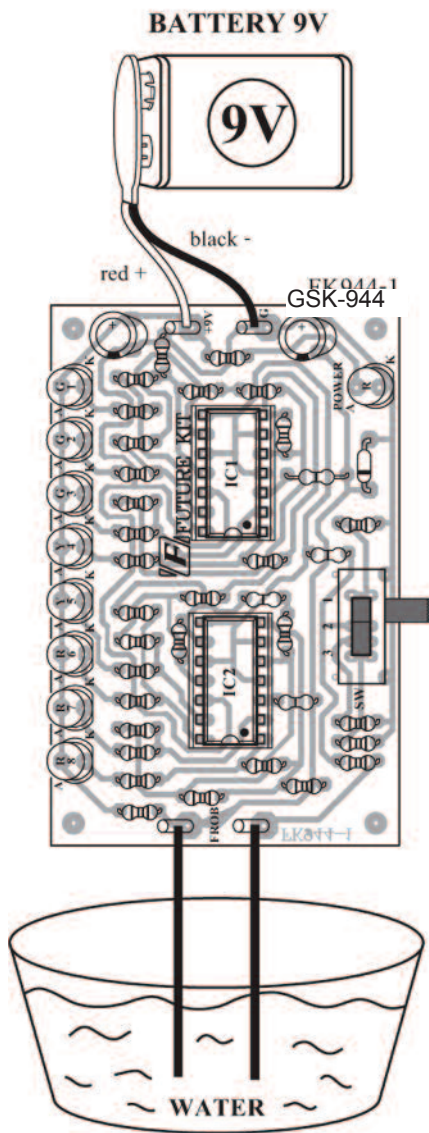
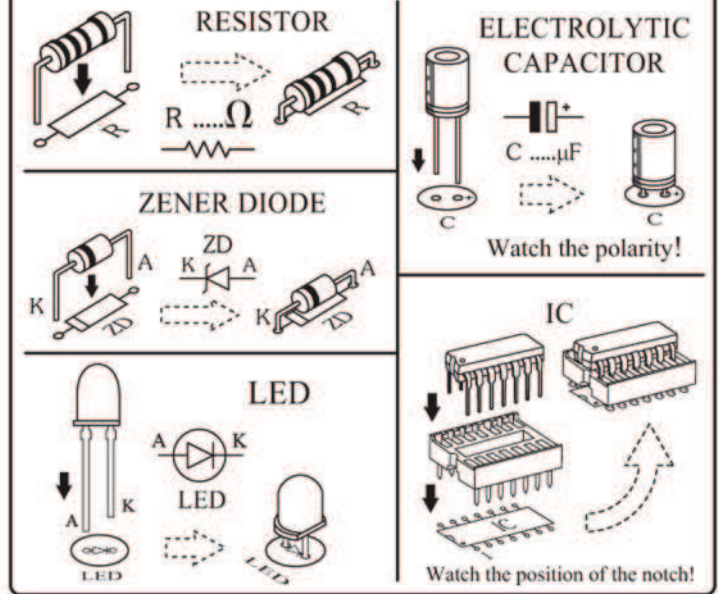

Figure 3 Installing components



Resistors

R1, 30	1 kΩ	brown – black – red – gold
R2, R8, R11, R14, R17, R20, R23, R26	10 kΩ	brown – black – orange – gold
R3	100 kΩ	brown – black – orange – gold
R4, R6, R9, R12, R15, R18, R21, R24, R27	1 MΩ	brown – black – green – gold
R5, R28	20 kΩ	red – black – orange – gold
R7, R19, R13, R16, R19, R22, R25, R28	5 kΩ	green – black – red – gold
R31	3 kΩ	orange – black – red – gold

Electrolytic Capacitors

C1, C2	33 μF
--------	-------

Diode

ZD1	5.1 V
-----	-------

Integrated Circuits

IC1, IC2	LM339
----------	-------

Switch

Position 1

LED	Water Resistance
8	0.98 kΩ
7	2.48 kΩ
6	4.41 kΩ
5	6.97 kΩ
4	10.57 kΩ
3	15.96 kΩ

Position 2

LED	Water Resistance
8	18.83 kΩ
7	33.80 kΩ
6	53.06 kΩ
5	78.74 kΩ
4	114.61 kΩ
3	168.61 kΩ
2	258.48 kΩ
1	438.22 kΩ

Position 3

LED	Water Resistance
8	197.26 kΩ
7	347.04 kΩ
6	539.62 kΩ
5	796.39 kΩ
4	1,155.86 kΩ
3	1,695.08 kΩ
2	2,593.77 kΩ
1	4,391.16 kΩ