



Chipsmall Limited consists of a professional team with an average of over 10 year of expertise in the distribution of electronic components. Based in Hongkong, we have already established firm and mutual-benefit business relationships with customers from,Europe,America and south Asia,supplying obsolete and hard-to-find components to meet their specific needs.

With the principle of "Quality Parts,Customers Priority,Honest Operation,and Considerate Service",our business mainly focus on the distribution of electronic components. Line cards we deal with include Microchip,ALPS,ROHM,Xilinx,Pulse,ON,Everlight and Freescale. Main products comprise IC,Modules,Potentiometer,IC Socket,Relay,Connector.Our parts cover such applications as commercial,industrial, and automotives areas.

We are looking forward to setting up business relationship with you and hope to provide you with the best service and solution. Let us make a better world for our industry!



## Contact us

Tel: +86-755-8981 8866 Fax: +86-755-8427 6832

Email & Skype: info@chipsmall.com Web: www.chipsmall.com

Address: A1208, Overseas Decoration Building, #122 Zhenhua RD., Futian, Shenzhen, China





soberton inc.

# GT MAGNETIC BUZZER

Acoustic Product Specification

Product Number: GT-0601A



Release | Revision: A/2018

## CONTENTS

This document contains the technical specifications for the magnetic buzzer.

### Page 1

Specifications

Mechanical Characteristics

### Page 2

Environment Test

Reliability Test

### Page 3

Measuring Method (Speaker Mode)

Soldering Condition

### Page 4

Dimensions

### Page 5

Packing

## Specifications

Item	Unit	Specification	Condition
Rated Voltage	Vo-p	1.5	
Operating Volt	Vo-p	1.0 ~ 3.0	
Current Consumption	mA	80 Max.	At rated voltage 3.0KHz, square wave, 1/2 duty
Coil Resistance	Ω	6 ±1	
Sound Pressure Level	dB	70	At 10cm at rated voltage
Oscillation Frequency	Hz	3000	
Operating Temp	°C	-20 ~ +60	
Storage Temp	°C	-30 ~ +70	
Dimension	mm	φ6.6 × H3.5	See dimension
Weight	gram	0.4	
Housing Material		PPO(Black)	
Terminal		Pin type	
Environmental Protection Regulation		RoHS	

### Test condition:

Temperature: +25±2 °C    Related humidity: 65±5%

## Mechanical Characteristics

Item	Test condition	Evaluation standard
Solderability	Lead terminals are immersed in rosin for 5 seconds and then immersed in solder bath at +250±5°C for 3±1 seconds	90% min. lead terminals will be wet with solder (Except the edge of terminal)
Soldering Heat Resistance	Lead terminals are immersed in soldering bath at +250±5°C for 3±1 second.	No interference in operation.
Terminal Mechanical Strength	Apply the terminal with 1Kg strength for 1 minute	No damage and cutting off
Vibration	Buzzer will be measured after being applied vibration of amplitude of 1.5mm with 10Hz to 55Hz band of vibration frequency to each of 3 perpendicular directions for 2 hours	The value of oscillation frequency current consumption would be in ±10% compared with initial ones.
Drop test	The part only will be dropped from a height of 75cm onto a 40mm thick wooden board 3 times in 3 axes(X,Y,Z). A total of 9 times.	The SPL would be in ±10dB compared with initial one.



soberton inc.

# GT MAGNETIC BUZZER

Acoustic Product Specification

Product Number: GT-0601A



Release | Revision: A/2018

## CONTENTS

This document contains the technical specifications for the magnetic buzzer.

### Page 1

Specifications

Mechanical Characteristics

### Page 2

Environment Test

Reliability Test

### Page 3

Measuring Method (Speaker Mode)

Soldering Condition

### Page 4

Dimensions

### Page 5

Packing

## Environment Test

Item	Test condition	Evaluation standard
High temp. test	After being placed in a chamber at +70°C for 96 hours	Being placed for 4 hours at +25°C, buzzer will be measured.
Low temp. test	After being placed in a chamber at -30°C for 96 hours	The value of oscillation, frequency / current consumption would be in ±10% compared with initial ones.
Humidity test	After being placed in a chamber at +70°C and 90±5% relative humidity for 96 hours	The SPL would be in ±10dB compared with initial one.
Temp cycle test	The part will be subjected to 5 cycles. One cycle shall consist of:	

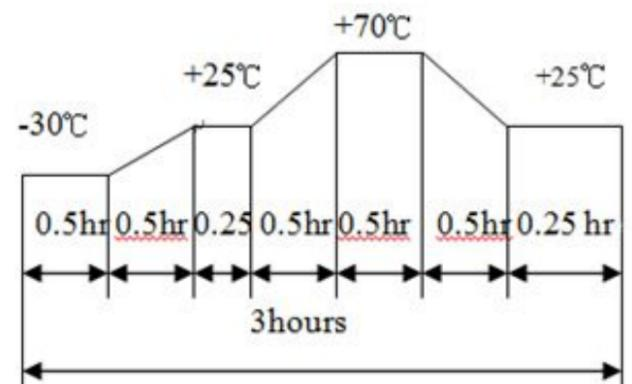

## Reliability Test

Item	Test condition	Evaluation standard
Operating life test	<b>1. Continuous life test</b> 48 hours continuous operation at +55°C with maximum rated voltage applied	After test, the part will meet specifications without any degradation in appearance and performance except SPL, after 4 hours at +25°C.
	<b>2. Intermittent life test</b> A duty cycle of 1 minute on, 1 minutes off, a minimum of 1000 times at +25±2°C and maximum rated voltage applied	The SPL would be in±10dBA compared with initial one.

### Standard test condition:

- a) Temperature: +5~+35°C
- b) Humidity: 45~85%
- c) Pressure: 860~1060mbar



soberton inc.

# GT MAGNETIC BUZZER

Acoustic Product Specification

Product Number: GT-0601A



Release | Revision: A/2018

## CONTENTS

This document contains the technical specifications for the magnetic buzzer.

### Page 1

Specifications

Mechanical Characteristics

### Page 2

Environment Test

Reliability Test

### Page 3

Measuring Method (Speaker Mode)

Soldering Condition

### Page 4

Dimensions

### Page 5

Packing

## Measuring Method (Speaker Mode)

### S.P.L Measuring Circuit

Input Signal: 1.5Vo-p, 3.0KHz, Square Wave

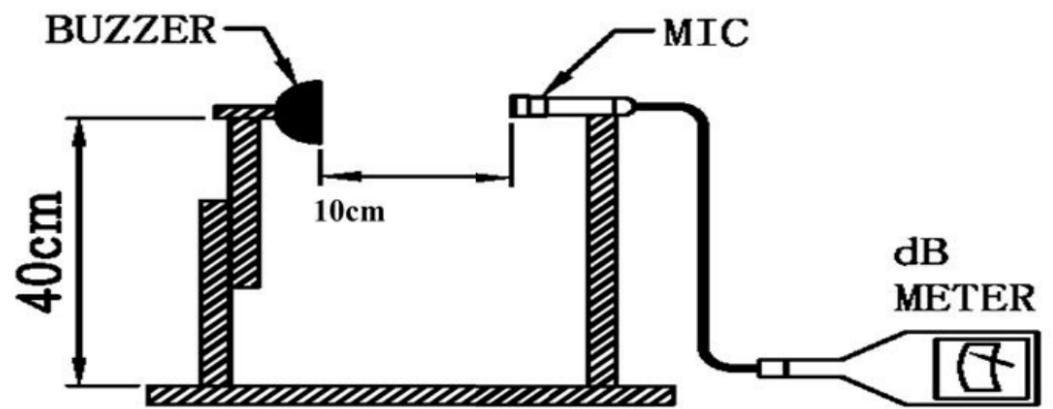

MIC: RION S.P.L meter UC30 or equivalent

S.G: Hewlett Packard 33120A Function Generator or equivalent

## Soldering Condition

### S.P.L Measuring Circuit

Recommended reflow soldering condition is as follows

Reflow soldering is twice

Note: It is requested that reflow soldering should be executed after heat of product goes down to normal temperature

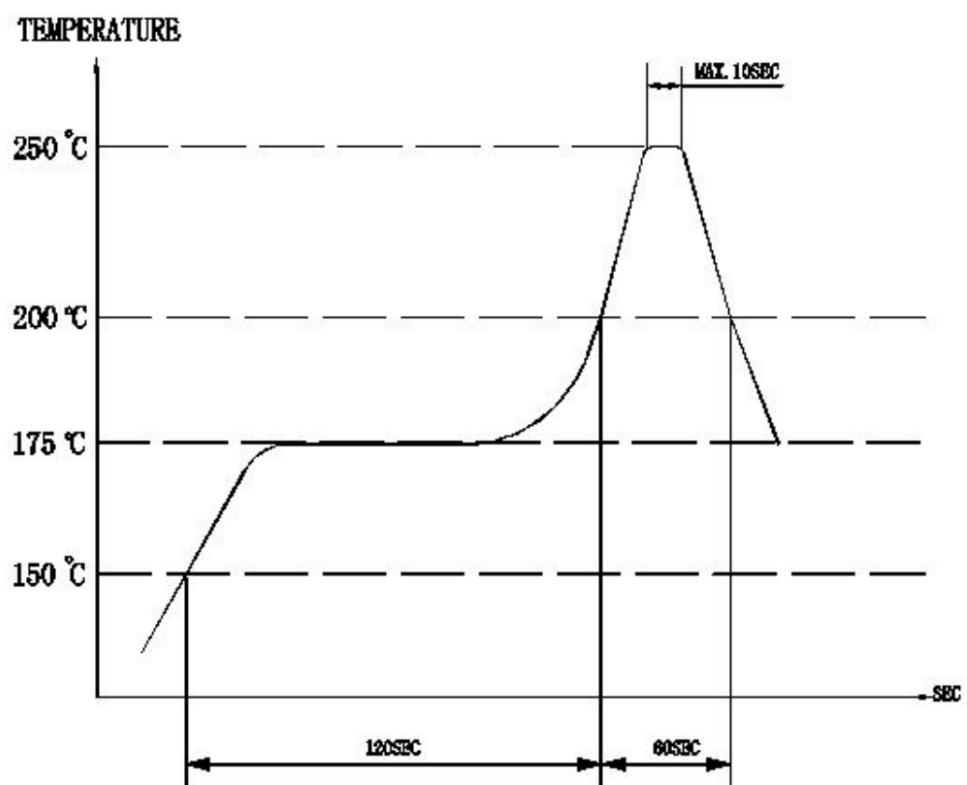

Heat resistant line (Use when heat resistant reliability test is performed)

### Manual Soldering

Manual soldering temperature 350 °C within 5 sec.



soberton inc.

# GT MAGNETIC BUZZER

Acoustic Product Specification

Product Number: GT-0601A



Release | Revision: A/2018

## CONTENTS

This document contains the technical specifications for the magnetic buzzer.

### Page 1

Specifications

Mechanical Characteristics

### Page 2

Environment Test

Reliability Test

### Page 3

Measuring Method (Speaker Mode)

Soldering Condition

### Page 4

Dimensions

### Page 5

Packing

## Dimensions

Tolerance:  $\pm 0.5$  (unit: mm)

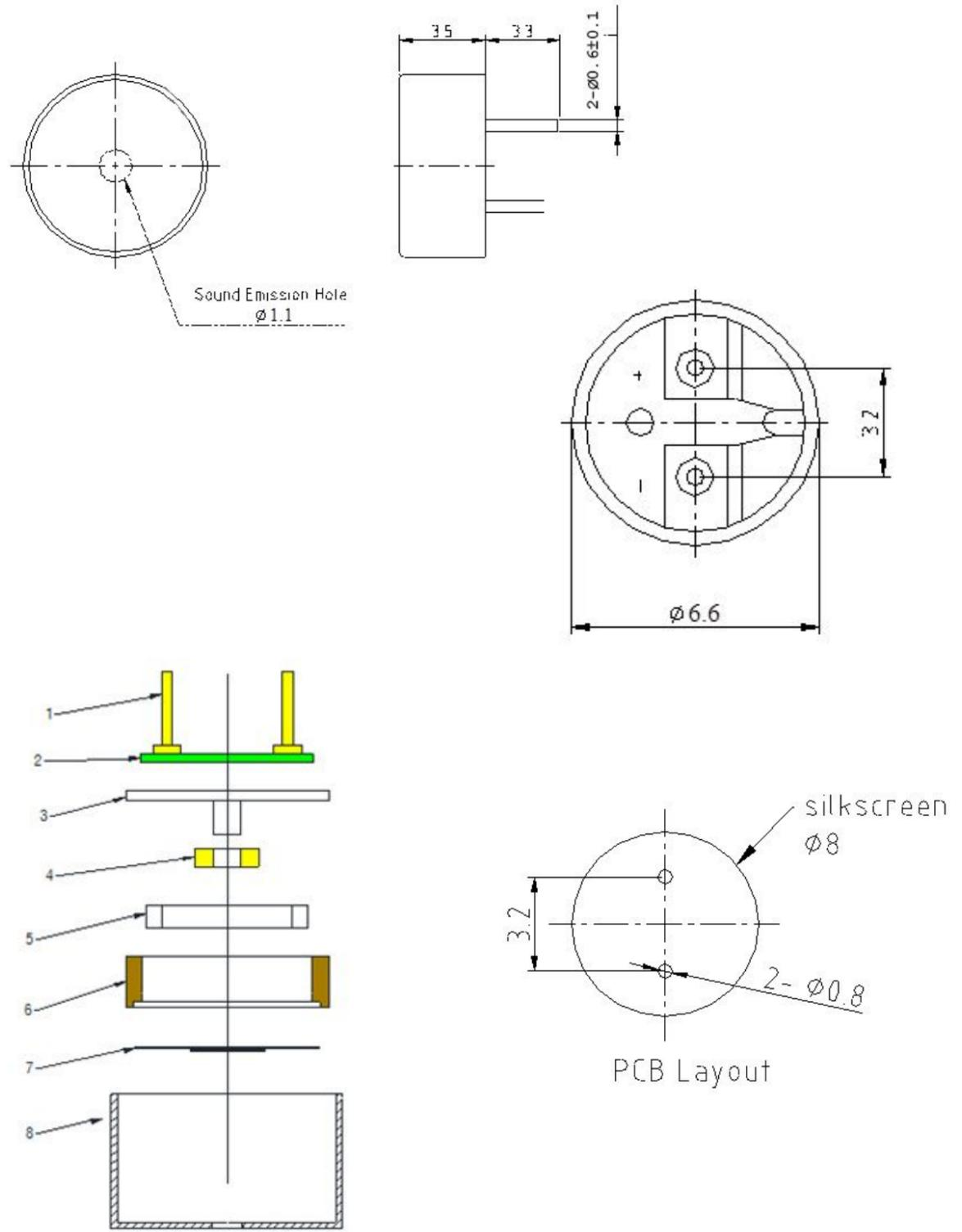

No.	Part Name	Material	Quantity
1	PIN	Copper	2
2	PCB	Epoxy glass fiber cloth + copper	1
3	Core	Ferrum	1
4	Coil	Copper	1
5	Magnet ring	NdFeB	1
6	Copper collar	Copper	1
7	Diaphragm	Ferrum	1
8	Case	PPO	1



soberton inc.

# GT MAGNETIC BUZZER

Acoustic Product Specification

Product Number: GT-0601A



Release | Revision: A/2018

## CONTENTS

This document contains the technical specifications for the magnetic buzzer.

### Page 1

Specifications

Mechanical Characteristics

### Page 2

Environment Test

Reliability Test

### Page 3

Measuring Method (Speaker Mode)

Soldering Condition

### Page 4

Dimensions

### Page 5

Packing

## Packing

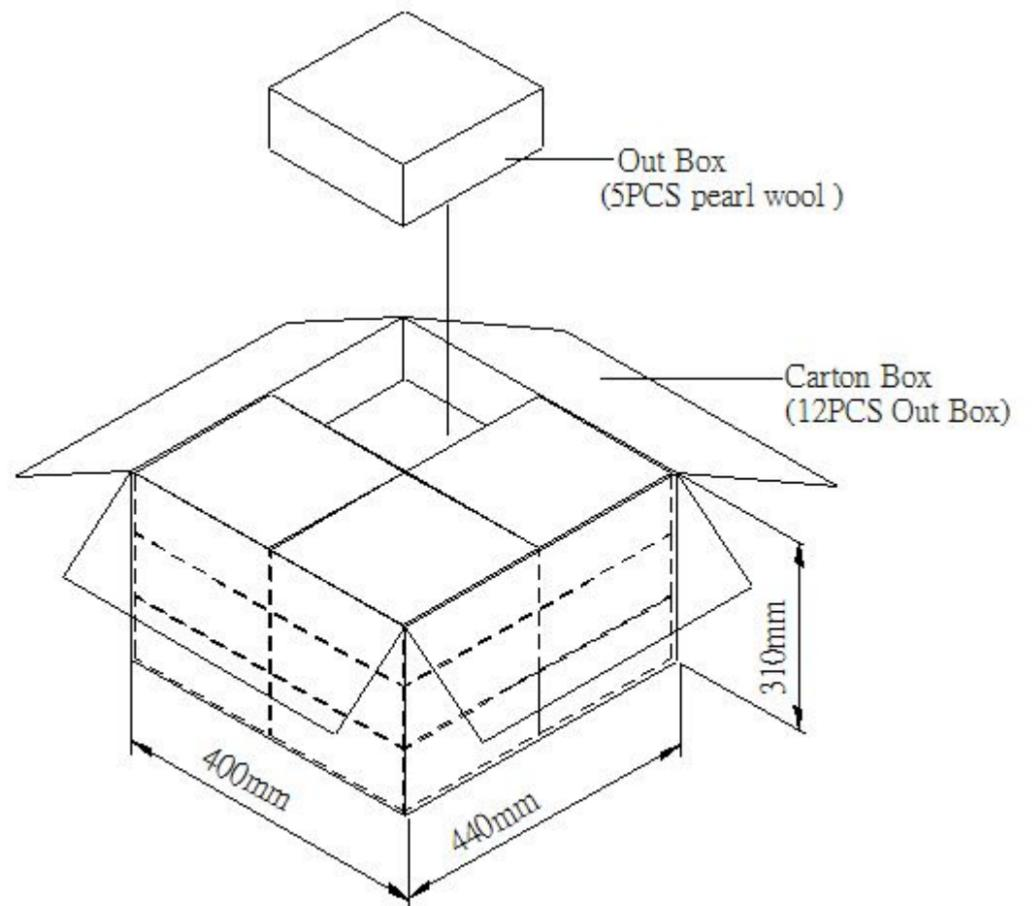
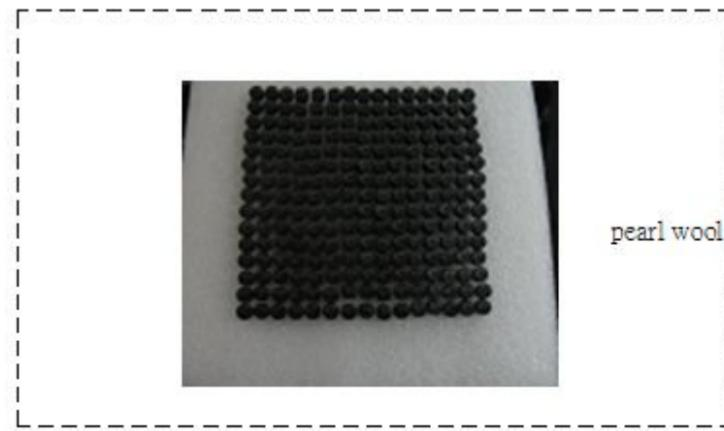

## Details

	Size (mm)	Quantity (pcs)
Pearl wool	184 x 184 x 10	225
Small box	200 x 190 x 100	1125
Big box	440 x 400 x 310	13500