



Chipsmall Limited consists of a professional team with an average of over 10 year of expertise in the distribution of electronic components. Based in Hongkong, we have already established firm and mutual-benefit business relationships with customers from,Europe,America and south Asia,supplying obsolete and hard-to-find components to meet their specific needs.

With the principle of “Quality Parts,Customers Priority,Honest Operation,and Considerate Service”,our business mainly focus on the distribution of electronic components. Line cards we deal with include Microchip,ALPS,ROHM,Xilinx,Pulse,ON,Everlight and Freescale. Main products comprise IC,Modules,Potentiometer,IC Socket,Relay,Connector.Our parts cover such applications as commercial,industrial, and automotives areas.

We are looking forward to setting up business relationship with you and hope to provide you with the best service and solution. Let us make a better world for our industry!



Contact us

Tel: +86-755-8981 8866 Fax: +86-755-8427 6832

Email & Skype: info@chipsmall.com Web: www.chipsmall.com

Address: A1208, Overseas Decoration Building, #122 Zhenhua RD., Futian, Shenzhen, China



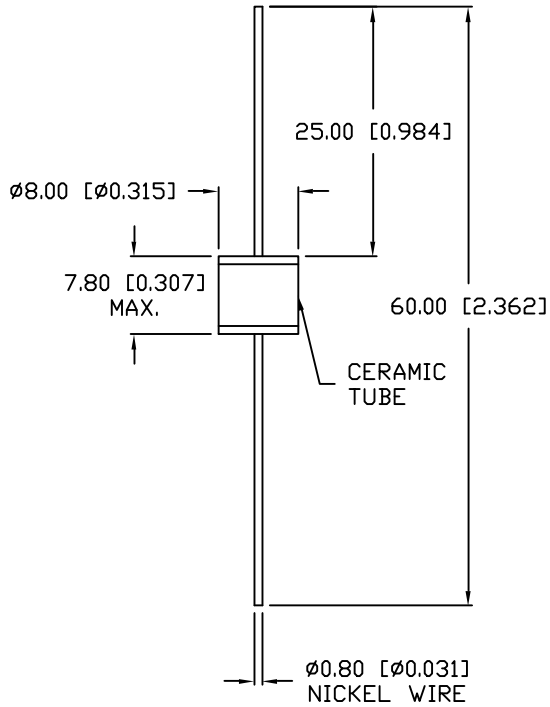

ELECTRICAL SPECIFICATIONS

PARAMETER	VALUE	TEST CONDITION
D.C. FIRING VOLTAGE:	600V±15% D.C.	(dv/dt 100V/S)
IMPULSE FIRING VOLTAGE:	900V D.C. MAX.	(dv/dt 100V/μS)
IMPULSE CURRENT:	10KA MAX.	(8/20μS)
D.C. HOLDOVER VOLTAGE:	200V D.C. MAX.	(150mS MAX.)
A.C. DISCHARGE CURRENT:	10A	(1S X 10 TIMES)
INSULATION RESISTANCE:	10 ³ MΩ MIN.	(50 OR 100VDC)
INTER-ELECTRODE CAPACITANCE:	0.5 PF MAX.	1.0kHz

ENVIRONMENTAL SPECIFICATIONS PER MIL-STD 202

TEST	METHODE	CONDITION	RATING
VIBRATION TESTING:	204B	C	10-55Hz, .06DA
SHOCK	213A	C	100 g
HUMIDITY:	103B	B	95% Re. HUMIDITY
TEMPERATURE CYCLING:	102A	C	-65 TO +125 °C
BAROMETRIC PRESSURE:	105C	B	50,000 ft.
THERMAL SHOCK:	107	B	-65 TO +125 °C
SOLDERABILITY:	208	B	

RESPONSE TIME

SURGE TYPE	(Rt MAX.)
1Kv/mS	1 x 10 ⁻⁵ sec.
1Kv/μS	1 x 10 ⁻⁸ sec.
5Kv/μS	1 x 10 ⁻⁹ sec.

*TOLERANCES PER DECIMAL PRECISION ARE: X=±1 (±0.039), X.X=±0.5 (±0.020), X.XX=±0.25 (±0.010), X.XXX=±0.127 (±0.005). LEAD LENGTH=±0.75 (±0.030). MIN= +DECIMAL PRECISION MAX= +0.00 -DECIMAL PRECISION

REV.	PART NUMBER GT-CM600L	<p>CONFIDENTIAL INFORMATION</p> <p>THE INFORMATION CONTAINED IN THIS DOCUMENT IS THE PROPERTY OF LUMEX INC. EXCEPT AS SPECIFICALLY AUTHORIZED IN WRITING BY LUMEX INC., THE HOLDER OF THIS DOCUMENT SHALL KEEP ALL INFORMATION CONTAINED HEREIN CONFIDENTIAL AND SHALL PROTECT SAME IN WHOLE OR IN PART FROM DISCLOSURE AND DISSEMINATION TO ALL THIRD PARTIES.</p>	<p>LUMEX INCORPORATED</p> <p>290 E. HELLEN ROAD PALATINE, ILLINOIS 60067 PHONE: (847) 359-2790 WEB: http://www.lumex.com</p>												
HEAVY DUTY CERAMIC SURGE PROTECTOR, 2 LEADED		<p>RELIABILITY NOTE</p> <p>OUR MANY YEARS OF EXPERIENCE DATA ACCUMULATION INDICATE THAT SOLDER HEAT IS A MAJOR CAUSE OF EARLY AND FUTURE FAILURE. PLEASE PAY ATTENTION TO YOUR SOLDERING PROCESS.</p>	<table border="1" style="width: 100%;"> <tr> <td>DRAWN BY: KS/SK</td> <td>CHECKED BY:</td> <td>APPROVED BY:</td> <td>DATE: 3-27-00</td> </tr> <tr> <td></td> <td></td> <td></td> <td>PAGE: 1 OF 1</td> </tr> <tr> <td></td> <td></td> <td></td> <td>SCALE: N/A</td> </tr> </table>	DRAWN BY: KS/SK	CHECKED BY:	APPROVED BY:	DATE: 3-27-00				PAGE: 1 OF 1				SCALE: N/A
DRAWN BY: KS/SK	CHECKED BY:	APPROVED BY:	DATE: 3-27-00												
			PAGE: 1 OF 1												
			SCALE: N/A												