



Chipsmall Limited consists of a professional team with an average of over 10 year of expertise in the distribution of electronic components. Based in Hongkong, we have already established firm and mutual-benefit business relationships with customers from,Europe,America and south Asia,supplying obsolete and hard-to-find components to meet their specific needs.

With the principle of “Quality Parts,Customers Priority,Honest Operation,and Considerate Service”,our business mainly focus on the distribution of electronic components. Line cards we deal with include Microchip,ALPS,ROHM,Xilinx,Pulse,ON,Everlight and Freescale. Main products comprise IC,Modules,Potentiometer,IC Socket,Relay,Connector.Our parts cover such applications as commercial,industrial, and automotives areas.

We are looking forward to setting up business relationship with you and hope to provide you with the best service and solution. Let us make a better world for our industry!



Contact us

Tel: +86-755-8981 8866 Fax: +86-755-8427 6832

Email & Skype: info@chipsmall.com Web: www.chipsmall.com

Address: A1208, Overseas Decoration Building, #122 Zhenhua RD., Futian, Shenzhen, China



GTL2005

Quad GTL/GTL+ to LVTTTL/TTL bidirectional non-latched translator

Rev. 06 — 6 September 2007

Product data sheet

1. General description

The GTL2005 is a quad translating transceiver designed for 3.3 V system interface with a GTL/GTL+ bus.

The direction pin (DIR) allows the part to function as either a GTL-to-TTL sampling receiver or as a TTL-to-GTL interface.

The GTL2005 LVTTTL interface is tolerant up to 5.5 V allowing direct access to TTL or 5 V CMOS outputs.

The GTL2005 V_{ref} linearity degrades below 0.8 V (see [Section 10.1](#)). If the application allows, use the GTL2014, otherwise more closely review noise margins.

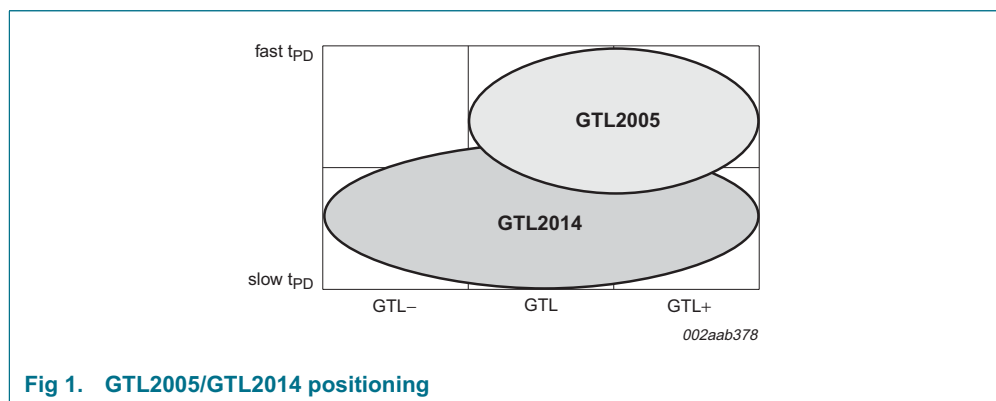

Fig 1. GTL2005/GTL2014 positioning

2. Features

- Operates as a quad GTL/GTL+ sampling receiver or as a LVTTTL/TTL to GTL/GTL+ driver
- Quad bidirectional bus interface
- 3.0 V to 3.6 V operation with 5 V tolerant LVTTTL I/O
- Live insertion/extraction permitted
- Latch-up protection exceeds 500 mA per JESD78
- ESD protection exceeds 2000 V HBM per JESD22-A114, 150 V MM per JESD22-A115, and 1000 V CDM per JESD22-CC101
- Package offered: TSSOP14

3. Quick reference data

Table 1. Quick reference data

$V_{CC} = 3.3\text{ V} \pm 0.3\text{ V}$

Symbol	Parameter	Conditions	Min	Typ ^[1]	Max	Unit
C_i	input capacitance	control inputs; $V_I = 3.0\text{ V}$ or 0 V	-	2.3	3.5	pF
C_{io}	input/output capacitance	A port; $V_O = V_{TT}$ or 0 V	-	3.4	5.0	pF
		B port; $V_O = 3.0\text{ V}$ or 0 V	-	6.0	7.0	pF

GTL; $V_{ref} = 0.8\text{ V}$

t_{PLH}	propagation delay, Bn to An	see Figure 7	-	2.1	2.3	ns
t_{PHL}			-	1.9	2.6	ns
t_{PLH}	propagation delay, An to Bn	see Figure 8	-	4.1	5.9	ns
t_{PHL}			-	4.4	5.9	ns

[1] All typical values are measured at $V_{CC} = 3.3\text{ V}$ and $T_{amb} = 25\text{ }^\circ\text{C}$.

4. Ordering information

Table 2. Ordering information

$T_{amb} = -40\text{ }^\circ\text{C}$ to $+85\text{ }^\circ\text{C}$

Type number	Topside mark	Package		
		Name	Description	Version
GTL2005PW	GTL2005	TSSOP14	plastic thin shrink small outline package; 14 leads; body width 4.4 mm	SOT402-1

5. Functional diagram

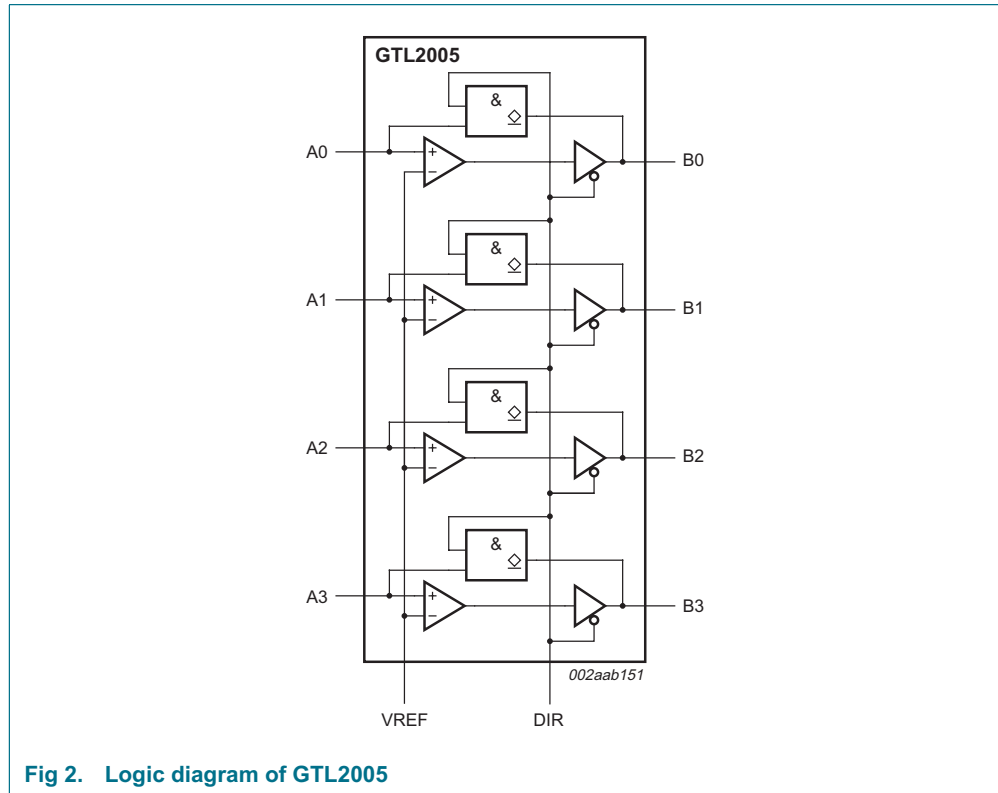

Fig 2. Logic diagram of GTL2005

6. Pinning information

6.1 Pinning

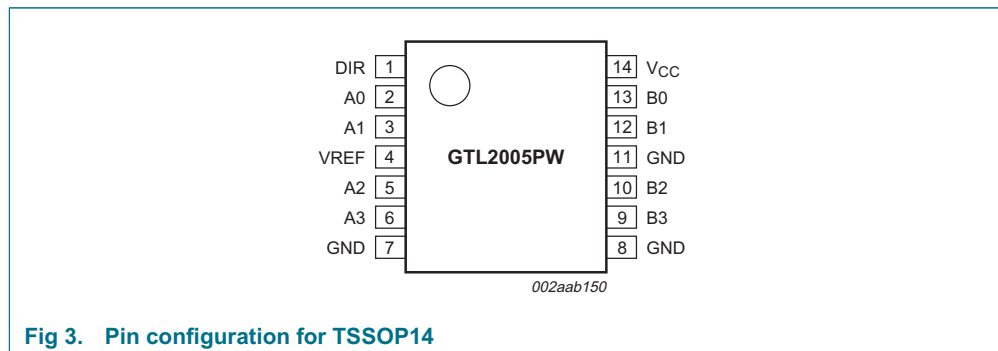

Fig 3. Pin configuration for TSSOP14

6.2 Pin description

Table 3. Pin description

Symbol	Pin	Description
DIR	1	direction control input
A0	2	data inputs/outputs (A side, GTL)
A1	3	
A2	5	
A3	6	
B0	13	data inputs/outputs (B side, TTL)
B1	12	
B2	10	
B3	9	
VREF	4	GTL reference voltage
GND	7, 8, 11	ground (0 V)
V _{CC}	14	positive supply voltage

7. Functional description

Refer to [Figure 2 “Logic diagram of GTL2005”](#) on page 3.

7.1 Function table

Table 4. Function table

H = HIGH voltage level; L = LOW voltage level.

Input	Input/output	
DIR	B (TTL)	A (GTL)
H	inputs	B _n = A _n
L	A _n = B _n	inputs

8. Limiting values

Table 5. Limiting values

In accordance with the Absolute Maximum Rating System (IEC 60134).^[1]
 Voltages are referenced to GND (ground = 0 V).

Symbol	Parameter	Conditions	Min	Max	Unit
V _{CC}	DC supply voltage		-0.5	+4.6	V
I _{IK}	DC input diode current	V _I < 0 V	-	-50	mA
V _I	DC input voltage	A port	-0.5 ^[3]	+7.0	V
		B port	-0.5 ^[3]	+4.6	V
I _{OK}	DC output diode current	V _O < 0 V	-	-50	mA
V _O	DC output voltage	output in OFF or HIGH state; A port	-0.5 ^[3]	+7.0	V
		output in OFF or HIGH state; B port	-0.5 ^[3]	+4.6	V
I _{OL}	current into any output in the LOW state	B port	-	128	mA
		A port	-	80	mA
I _{OH}	current into any output in the HIGH state	B port	-	-64	mA
T _{stg}	storage temperature range		^[2] -60	+150	°C

- [1] Stresses beyond those listed may cause permanent damage to the device. These are stress ratings only and functional operation of the device at these or any other conditions beyond those indicated under [Section 9 "Recommended operating conditions"](#) is not implied. Exposure to absolute-maximum-rated conditions for extended periods may affect device reliability.
- [2] The performance capability of a high-performance integrated circuit in conjunction with its thermal environment can create junction temperatures which are detrimental to reliability. The maximum junction temperature of this integrated circuit should not exceed 150 °C.
- [3] The input and output negative voltage ratings may be exceeded if the input and output clamp current ratings are observed.

9. Recommended operating conditions

Table 6. Operating conditions [1]

Symbol	Parameter	Conditions	Min	Typ	Max	Unit
V _{CC}	supply voltage		3.0	3.3	3.6	V
V _{TT}	termination voltage	GTL–	0.85	0.9	0.95	V
		GTL	1.14	1.2	1.26	V
		GTL+	1.35	1.5	1.65	V
V _{ref}	reference voltage	overall	[2] 0.5	$\frac{2}{3}V_{TT}$	1.8	V
		GTL–	0.5	0.6	0.63	V
		GTL	0.76	0.8	0.84	V
		GTL+	0.87	1.0	1.10	V
V _I	input voltage	A port	0	V _{TT}	3.6	V
		except A port	0	3.3	5.5	V
V _{IH}	HIGH-level input voltage	A port	[3]	-	-	V
		except A port	2	-	-	V
V _{IL}	LOW-level input voltage	A port	-	-	[3]	V
		except A port	-	-	0.8	V
I _{OH}	HIGH-level output current	B port	-	-	-12	mA
I _{OL}	LOW-level output current	A port	-	-	40	mA
		B port	-	-	12	mA
T _{amb}	ambient temperature	operating in free-air	-40	-	+85	°C

[1] Unused inputs must be held HIGH or LOW to prevent them from floating.

[2] V_{ref} is normally $\frac{2}{3}V_{TT}$, but based upon application and noise margin requirements can be set anywhere within this range and does not need to follow GTL-/GTL/GTL+ specification.

[3] Nominally ± 50 mV around V_{ref}. See [Figure 4](#), [Figure 5](#), and [Figure 6](#) for actual performance versus V_{ref}, V_{CC}, and temperature.

10. Static characteristics

Table 7. Static characteristics

Recommended operating conditions; voltages are referenced to GND (ground = 0 V); $T_{amb} = -40\text{ }^{\circ}\text{C}$ to $+85\text{ }^{\circ}\text{C}$.

Symbol	Parameter	Conditions	Min	Typ ^[1]	Max	Unit
V_{OH}	HIGH-level output voltage	B port; $V_{CC} = 3.0\text{ V}$ to 3.6 V ; $I_{OH} = -100\text{ }\mu\text{A}$	[2] $V_{CC} - 0.2$	-	-	V
		B port; $V_{CC} = 3.0\text{ V}$; $I_{OH} = -12\text{ mA}$	[2] 2.0	-	-	V
V_{OL}	LOW-level output voltage	A port; $V_{CC} = 3.0\text{ V}$; $I_{OL} = 40\text{ mA}$	[2] -	-	0.4	V
		B port; $V_{CC} = 3.0\text{ V}$; $I_{OL} = 4\text{ mA}$	[2] -	-	0.4	V
		B port; $V_{CC} = 3.0\text{ V}$; $I_{OL} = 8\text{ mA}$	[2] -	-	0.55	V
		B port; $V_{CC} = 3.0\text{ V}$; $I_{OL} = 12\text{ mA}$	[2] -	-	0.8	V
I_I	input current	control inputs; $V_{CC} = 3.6\text{ V}$; $V_I = V_{CC}$ or GND	-	-	± 1	μA
		A port; $V_{CC} = 3.6\text{ V}$; $V_I = V_{TT}$ or GND	-	-	± 1	μA
		B port; $V_{CC} = 0\text{ V}$ or 3.6 V ; $V_I = 5.5\text{ V}$	-	-	10	μA
		B port; $V_{CC} = 3.6\text{ V}$; $V_I = V_{CC}$	-	-	± 1	μA
		B port; $V_{CC} = 3.6\text{ V}$; $V_I = 0\text{ V}$	-	-	-5	μA
I_{OFF}	output OFF current	A port; $V_{CC} = 0\text{ V}$; V_I or $V_O = 0\text{ V}$ to 4.5 V	-	-	± 100	μA
I_{EX}	high contention over voltage leakage current	B port; $V_{CC} = 3.0\text{ V}$; $V_O = 5.5\text{ V}$	-	50	125	μA
I_{CC}	supply current	A or B port; $V_{CC} = 3.6\text{ V}$; $V_I = V_{CC}$ or GND; $I_O = 0\text{ mA}$	-	-	3	mA
ΔI_{CC} ^[3]	additional supply current per input	B port or control inputs; $V_{CC} = 3.6\text{ V}$; $V_I = V_{CC} - 0.6\text{ V}$	-	-	500	μA
C_i	input capacitance	control inputs; $V_I = 3.0\text{ V}$ or 0 V	-	2.3	3.5	pF
C_{iO}	input/output capacitance	A port; $V_O = V_{TT}$ or 0 V	-	3.4	5.0	pF
		B port; $V_O = 3.0\text{ V}$ or 0 V	-	6.0	7.0	pF

[1] All typical values are measured at $V_{CC} = 3.3\text{ V}$ and $T_{amb} = 25\text{ }^{\circ}\text{C}$.

[2] The input and output voltage ratings may be exceeded if the input and output current ratings are observed.

[3] This is the increase in supply current for each input that is at the specified TTL voltage level rather than V_{CC} or GND.

10.1 Performance curves

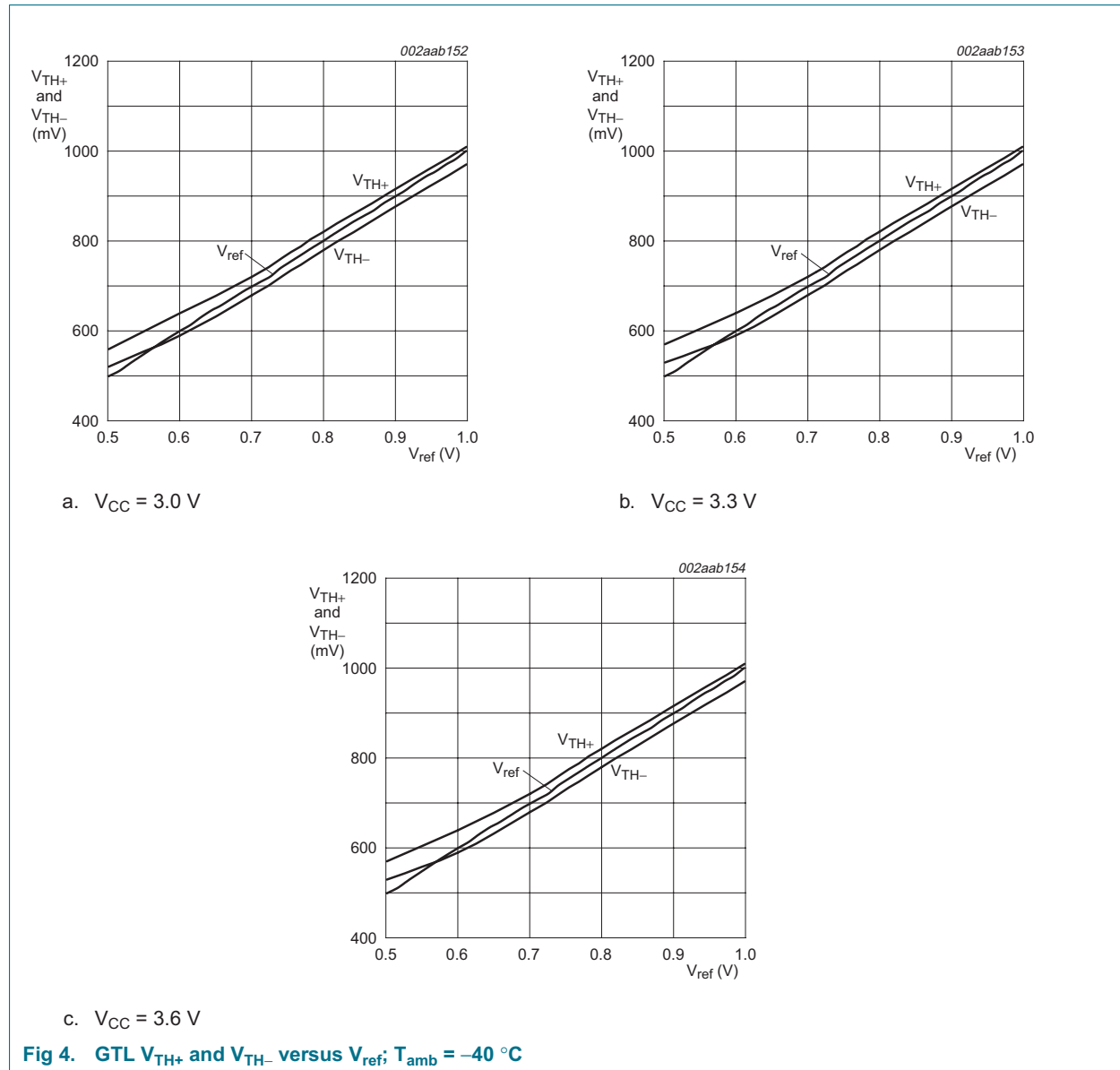

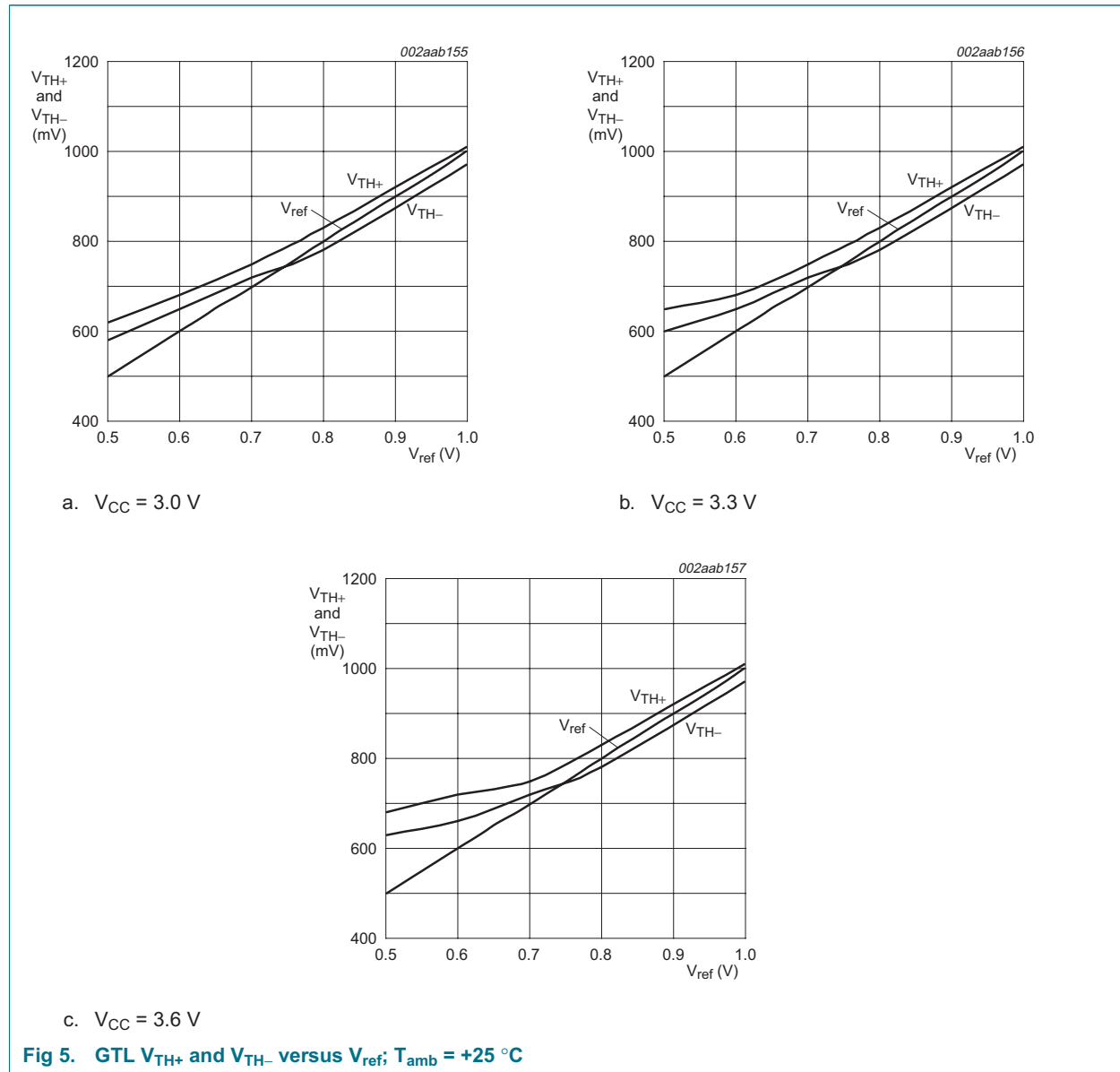

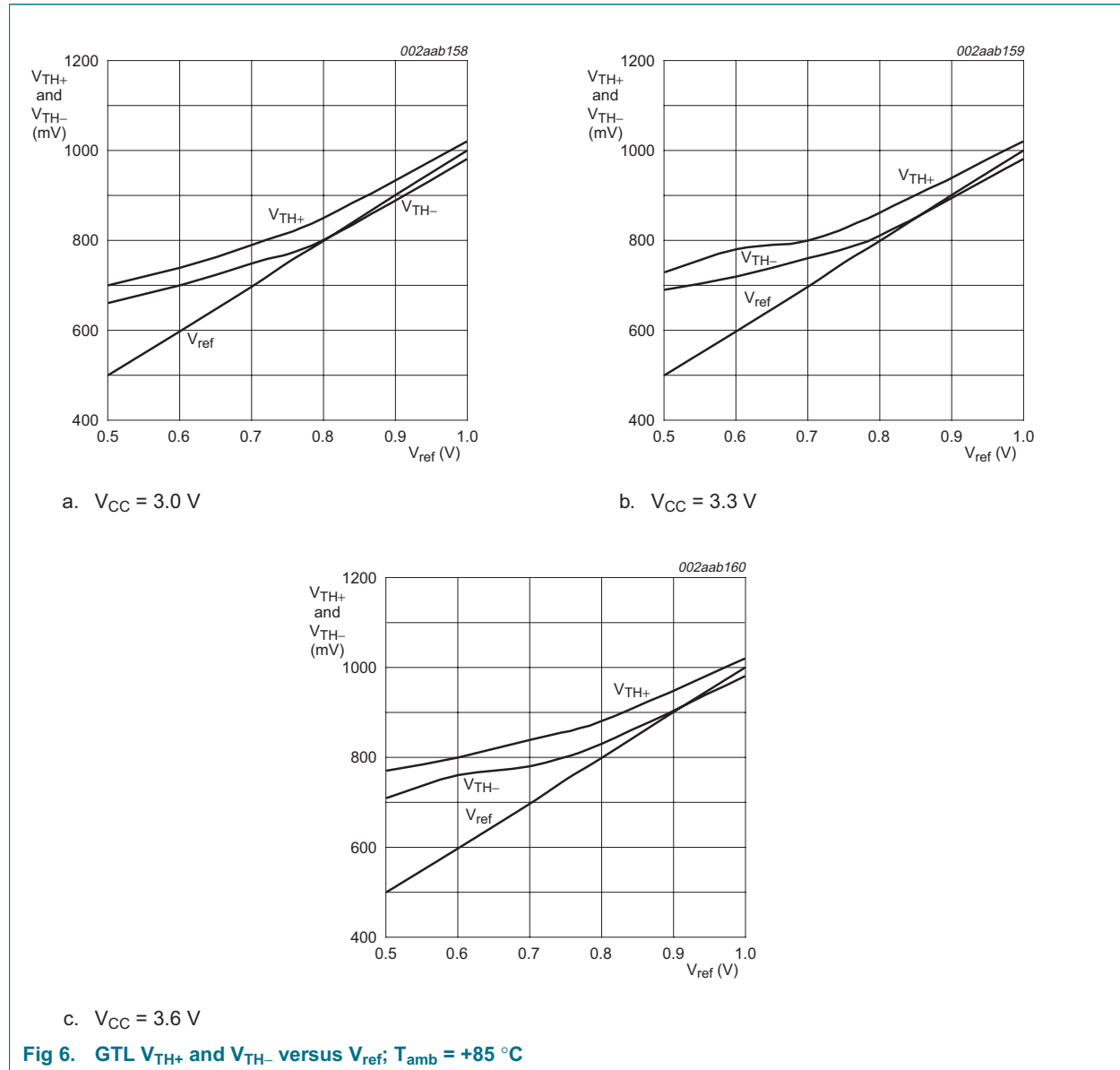

11. Dynamic characteristics

Table 8. Dynamic characteristics

$V_{CC} = 3.3\text{ V} \pm 0.3\text{ V}$

Symbol	Parameter	Conditions	Min	Typ ^[1]	Max	Unit
GTL-; $V_{ref} = 0.6\text{ V}$						
t_{PLH}	propagation delay, Bn to An	see Figure 7	-	2.1	2.3	ns
t_{PHL}			-	1.9	2.6	ns
t_{PLH}	propagation delay, An to Bn	see Figure 8	-	4.1	5.9	ns
t_{PHL}			-	4.4	5.9	ns
GTL; $V_{ref} = 0.8\text{ V}$						
t_{PLH}	propagation delay, Bn to An	see Figure 7	-	2.1	2.3	ns
t_{PHL}			-	1.9	2.6	ns
t_{PLH}	propagation delay, An to Bn	see Figure 8	-	4.1	5.9	ns
t_{PHL}			-	4.4	5.9	ns
GTL+; $V_{ref} = 1.0\text{ V}$						
t_{PLH}	propagation delay, Bn to An	see Figure 7	-	2.1	2.3	ns
t_{PHL}			-	1.9	2.6	ns
t_{PLH}	propagation delay, An to Bn	see Figure 8	-	4.2	5.7	ns
t_{PHL}			-	3.8	5.4	ns

[1] All typical values are at $V_{CC} = 3.3\text{ V}$ and $T_{amb} = 25\text{ }^\circ\text{C}$.

11.1 Waveforms

$V_M = 1.5\text{ V}$ at $V_{CC} \geq 3.0\text{ V}$; $V_M = V_{CC}/2$ at $V_{CC} \leq 2.7\text{ V}$ for B ports and control pins;
 $V_M = V_{ref}$ for A ports.

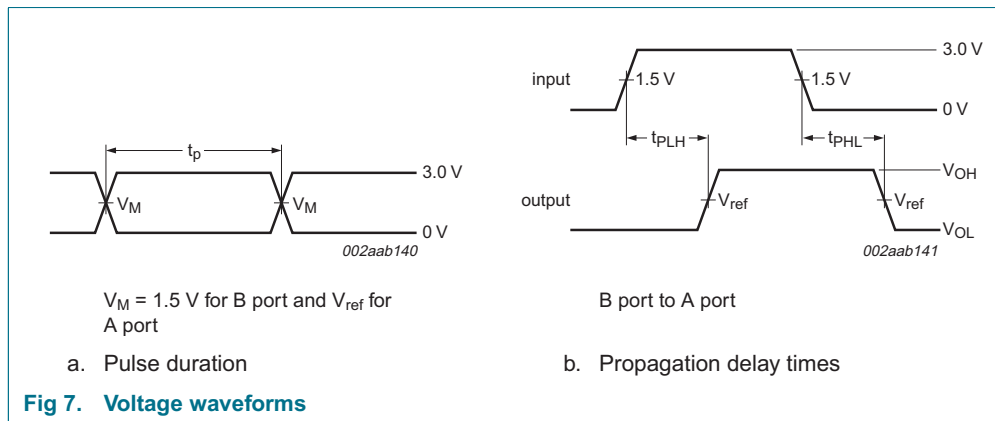

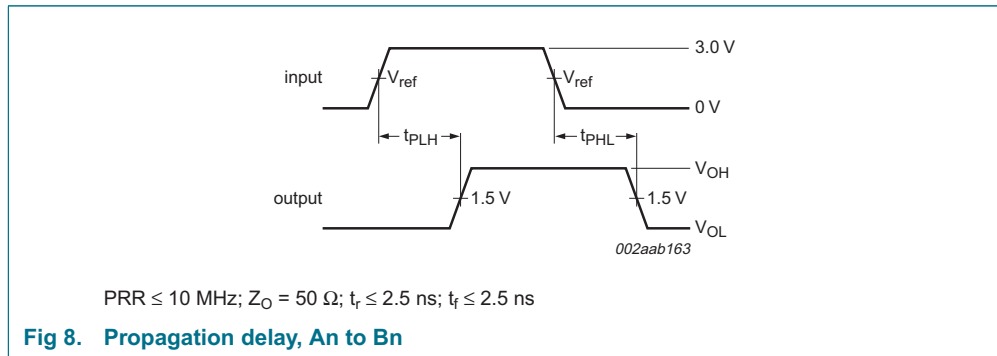

12. Test information

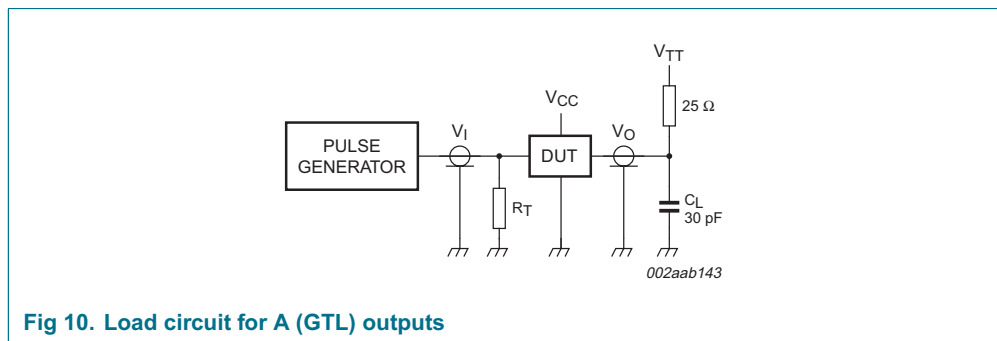
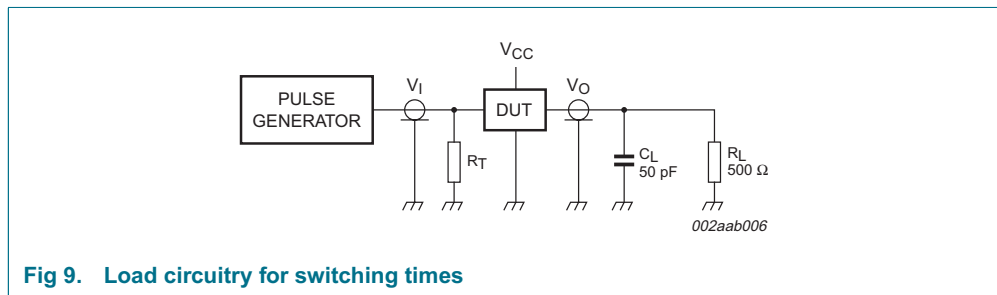

R_L — Load resistor

C_L — Load capacitance; includes jig and probe capacitance

R_T — Termination resistance; should be equal to Z_{OUT} of pulse generators.

13. Package outline

TSSOP14: plastic thin shrink small outline package; 14 leads; body width 4.4 mm

SOT402-1

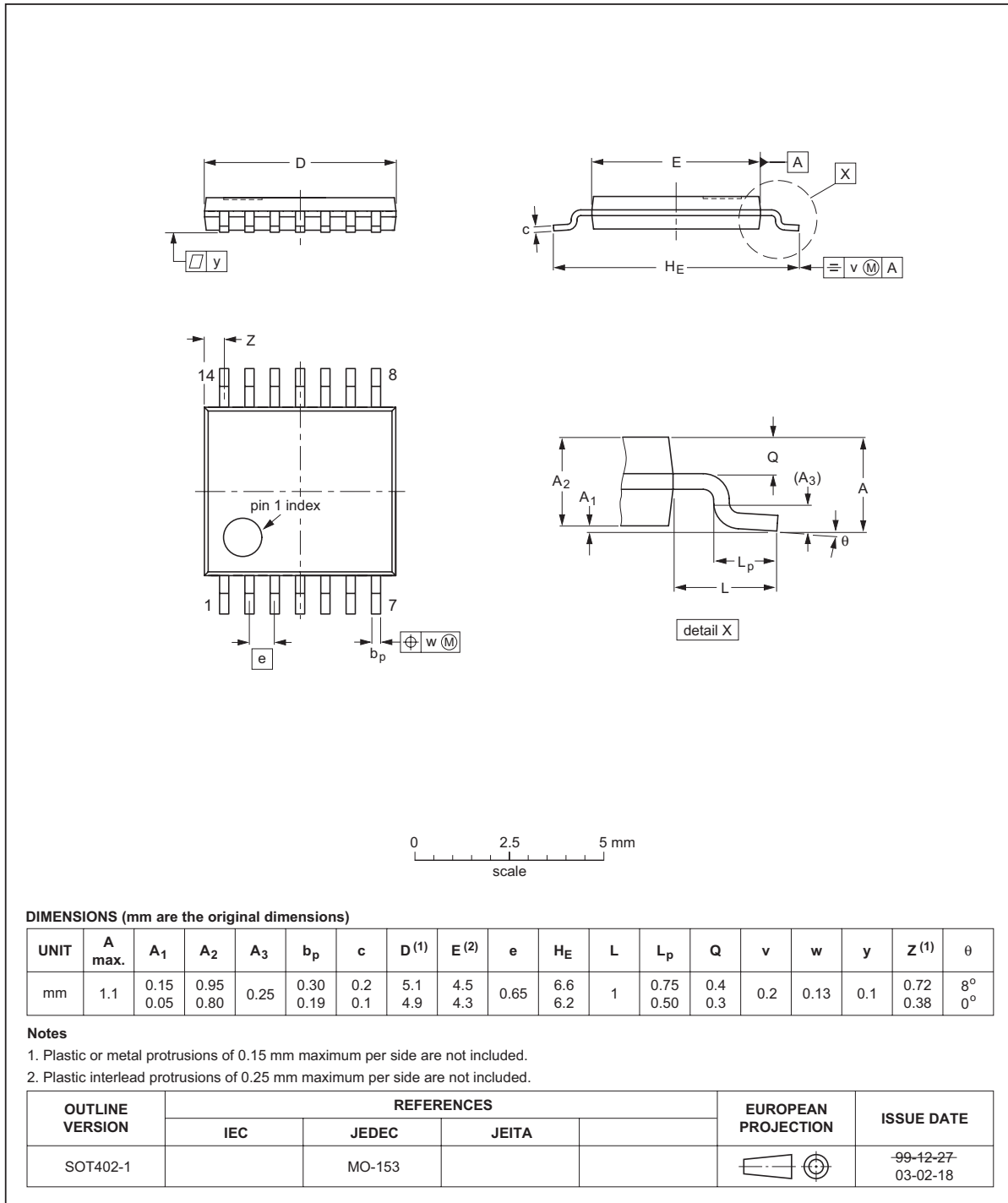

Fig 11. Package outline SOT402-1 (TSSOP14)

14. Soldering

This text provides a very brief insight into a complex technology. A more in-depth account of soldering ICs can be found in Application Note AN10365 “Surface mount reflow soldering description”.

14.1 Introduction to soldering

Soldering is one of the most common methods through which packages are attached to Printed Circuit Boards (PCBs), to form electrical circuits. The soldered joint provides both the mechanical and the electrical connection. There is no single soldering method that is ideal for all IC packages. Wave soldering is often preferred when through-hole and Surface Mount Devices (SMDs) are mixed on one printed wiring board; however, it is not suitable for fine pitch SMDs. Reflow soldering is ideal for the small pitches and high densities that come with increased miniaturization.

14.2 Wave and reflow soldering

Wave soldering is a joining technology in which the joints are made by solder coming from a standing wave of liquid solder. The wave soldering process is suitable for the following:

- Through-hole components
- Leaded or leadless SMDs, which are glued to the surface of the printed circuit board

Not all SMDs can be wave soldered. Packages with solder balls, and some leadless packages which have solder lands underneath the body, cannot be wave soldered. Also, leaded SMDs with leads having a pitch smaller than ~0.6 mm cannot be wave soldered, due to an increased probability of bridging.

The reflow soldering process involves applying solder paste to a board, followed by component placement and exposure to a temperature profile. Leaded packages, packages with solder balls, and leadless packages are all reflow solderable.

Key characteristics in both wave and reflow soldering are:

- Board specifications, including the board finish, solder masks and vias
- Package footprints, including solder thieves and orientation
- The moisture sensitivity level of the packages
- Package placement
- Inspection and repair
- Lead-free soldering versus PbSn soldering

14.3 Wave soldering

Key characteristics in wave soldering are:

- Process issues, such as application of adhesive and flux, clinching of leads, board transport, the solder wave parameters, and the time during which components are exposed to the wave
- Solder bath specifications, including temperature and impurities

14.4 Reflow soldering

Key characteristics in reflow soldering are:

- Lead-free versus SnPb soldering; note that a lead-free reflow process usually leads to higher minimum peak temperatures (see [Figure 12](#)) than a PbSn process, thus reducing the process window
- Solder paste printing issues including smearing, release, and adjusting the process window for a mix of large and small components on one board
- Reflow temperature profile; this profile includes preheat, reflow (in which the board is heated to the peak temperature) and cooling down. It is imperative that the peak temperature is high enough for the solder to make reliable solder joints (a solder paste characteristic). In addition, the peak temperature must be low enough that the packages and/or boards are not damaged. The peak temperature of the package depends on package thickness and volume and is classified in accordance with [Table 9](#) and [10](#)

Table 9. SnPb eutectic process (from J-STD-020C)

Package thickness (mm)	Package reflow temperature (°C)	
	Volume (mm ³)	
	< 350	≥ 350
< 2.5	235	220
≥ 2.5	220	220

Table 10. Lead-free process (from J-STD-020C)

Package thickness (mm)	Package reflow temperature (°C)		
	Volume (mm ³)		
	< 350	350 to 2000	> 2000
< 1.6	260	260	260
1.6 to 2.5	260	250	245
> 2.5	250	245	245

Moisture sensitivity precautions, as indicated on the packing, must be respected at all times.

Studies have shown that small packages reach higher temperatures during reflow soldering, see [Figure 12](#).

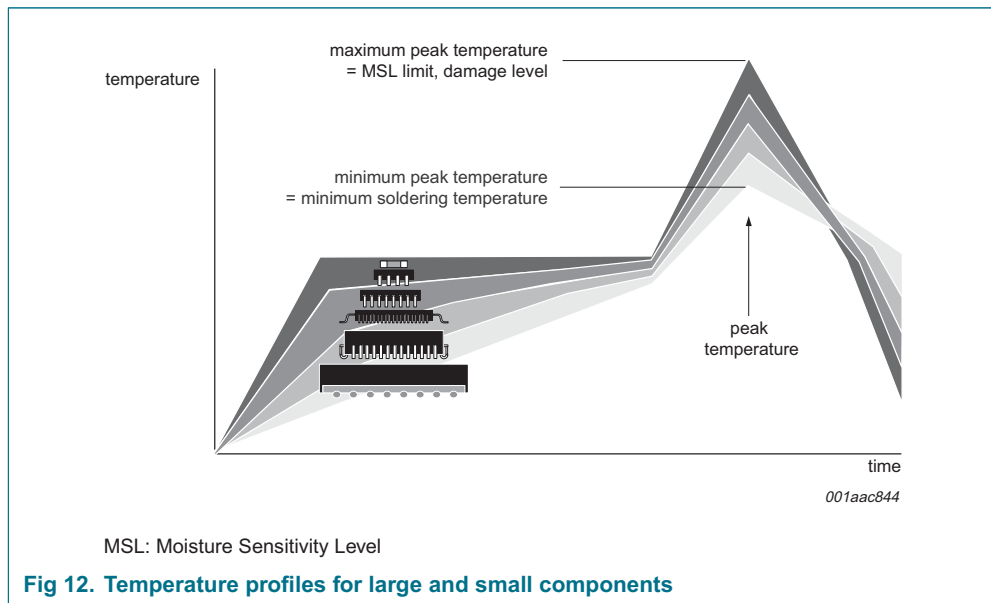

For further information on temperature profiles, refer to Application Note AN10365 “Surface mount reflow soldering description”.

15. Abbreviations

Table 11. Abbreviations

Acronym	Description
CDM	Charged Device Model
CMOS	Complementary Metal Oxide Silicon
DUT	Device Under Test
ESD	ElectroStatic Discharge
GTL	Gunning Transceiver Logic
HBM	Human Body Model
I/O	Input/Output
LVTTTL	Low Voltage Transistor-Transistor Logic
MM	Machine Model
TTL	Transistor-Transistor Logic

16. Revision history

Table 12. Revision history

Document ID	Release date	Data sheet status	Change notice	Supersedes
GTL2005_6	20070906	Product data sheet	-	GTL2005_5
Modifications:	<ul style="list-style-type: none"> • The format of this data sheet has been redesigned to comply with the new identity guidelines of NXP Semiconductors. • Legal texts have been adapted to the new company name where appropriate. • Section 1 “General description”: 4th paragraph re-written. • Figure 1 “GTL2005/GTL2014 positioning” modified (removed reference to GTL2024). • Table 1 “Quick reference data” updated (presentation to match characteristics tables) • Figure 2 “Logic diagram of GTL2005” modified (changed buffer symbol to open-drain AND gate). • Table 5 “Limiting values”: <ul style="list-style-type: none"> – Conditions for I_{OL}: changed ‘A port’ to ‘B port’, and ‘B port’ to ‘A port’ – Conditions for I_{OH}: changed ‘A port’ to ‘B port’ • Added Section 17.4 “Trademarks”. 			
GTL2005_5 (9397 750 14285)	20050406	Product data sheet	-	GTL2005_4
GTL2005_4 (9397 750 13104)	20040510	Product data	-	GTL2005_3
GTL2005_3 (9397 750 07222)	20000619	Product data	853-2171 23901	GTL2005_2
GTL2005_2 (9397 750 06695)	19990917	Product data	853-2171 22353	GTL2005_1
GTL2005_1 (9397 750 06497)	19990917	Product data	-	-

17. Legal information

17.1 Data sheet status

Document status ^{[1][2]}	Product status ^[3]	Definition
Objective [short] data sheet	Development	This document contains data from the objective specification for product development.
Preliminary [short] data sheet	Qualification	This document contains data from the preliminary specification.
Product [short] data sheet	Production	This document contains the product specification.

[1] Please consult the most recently issued document before initiating or completing a design.

[2] The term 'short data sheet' is explained in section "Definitions".

[3] The product status of device(s) described in this document may have changed since this document was published and may differ in case of multiple devices. The latest product status information is available on the Internet at URL <http://www.nxp.com>.

17.2 Definitions

Draft — The document is a draft version only. The content is still under internal review and subject to formal approval, which may result in modifications or additions. NXP Semiconductors does not give any representations or warranties as to the accuracy or completeness of information included herein and shall have no liability for the consequences of use of such information.

Short data sheet — A short data sheet is an extract from a full data sheet with the same product type number(s) and title. A short data sheet is intended for quick reference only and should not be relied upon to contain detailed and full information. For detailed and full information see the relevant full data sheet, which is available on request via the local NXP Semiconductors sales office. In case of any inconsistency or conflict with the short data sheet, the full data sheet shall prevail.

17.3 Disclaimers

General — Information in this document is believed to be accurate and reliable. However, NXP Semiconductors does not give any representations or warranties, expressed or implied, as to the accuracy or completeness of such information and shall have no liability for the consequences of use of such information.

Right to make changes — NXP Semiconductors reserves the right to make changes to information published in this document, including without limitation specifications and product descriptions, at any time and without notice. This document supersedes and replaces all information supplied prior to the publication hereof.

Suitability for use — NXP Semiconductors products are not designed, authorized or warranted to be suitable for use in medical, military, aircraft, space or life support equipment, nor in applications where failure or

malfunction of a NXP Semiconductors product can reasonably be expected to result in personal injury, death or severe property or environmental damage. NXP Semiconductors accepts no liability for inclusion and/or use of NXP Semiconductors products in such equipment or applications and therefore such inclusion and/or use is at the customer's own risk.

Applications — Applications that are described herein for any of these products are for illustrative purposes only. NXP Semiconductors makes no representation or warranty that such applications will be suitable for the specified use without further testing or modification.

Limiting values — Stress above one or more limiting values (as defined in the Absolute Maximum Ratings System of IEC 60134) may cause permanent damage to the device. Limiting values are stress ratings only and operation of the device at these or any other conditions above those given in the Characteristics sections of this document is not implied. Exposure to limiting values for extended periods may affect device reliability.

Terms and conditions of sale — NXP Semiconductors products are sold subject to the general terms and conditions of commercial sale, as published at <http://www.nxp.com/profile/terms>, including those pertaining to warranty, intellectual property rights infringement and limitation of liability, unless explicitly otherwise agreed to in writing by NXP Semiconductors. In case of any inconsistency or conflict between information in this document and such terms and conditions, the latter will prevail.

No offer to sell or license — Nothing in this document may be interpreted or construed as an offer to sell products that is open for acceptance or the grant, conveyance or implication of any license under any copyrights, patents or other industrial or intellectual property rights.

17.4 Trademarks

Notice: All referenced brands, product names, service names and trademarks are the property of their respective owners.

18. Contact information

For additional information, please visit: <http://www.nxp.com>

For sales office addresses, send an email to: salesaddresses@nxp.com

19. Contents

1	General description	1
2	Features	1
3	Quick reference data	2
4	Ordering information	2
5	Functional diagram	3
6	Pinning information	3
6.1	Pinning	3
6.2	Pin description	4
7	Functional description	4
7.1	Function table	4
8	Limiting values	5
9	Recommended operating conditions	6
10	Static characteristics	7
10.1	Performance curves	8
11	Dynamic characteristics	11
11.1	Waveforms	11
12	Test information	12
13	Package outline	13
14	Soldering	14
14.1	Introduction to soldering	14
14.2	Wave and reflow soldering	14
14.3	Wave soldering	14
14.4	Reflow soldering	15
15	Abbreviations	16
16	Revision history	17
17	Legal information	18
17.1	Data sheet status	18
17.2	Definitions	18
17.3	Disclaimers	18
17.4	Trademarks	18
18	Contact information	18
19	Contents	19

Please be aware that important notices concerning this document and the product(s) described herein, have been included in section 'Legal information'.

founded by

PHILIPS

© NXP B.V. 2007.

All rights reserved.

For more information, please visit: <http://www.nxp.com>

For sales office addresses, please send an email to: salesaddresses@nxp.com

Date of release: 6 September 2007

Document identifier: GTL2005_6