



Chipsmall Limited consists of a professional team with an average of over 10 year of expertise in the distribution of electronic components. Based in Hongkong, we have already established firm and mutual-benefit business relationships with customers from,Europe,America and south Asia,supplying obsolete and hard-to-find components to meet their specific needs.

With the principle of "Quality Parts,Customers Priority,Honest Operation,and Considerate Service",our business mainly focus on the distribution of electronic components. Line cards we deal with include Microchip,ALPS,ROHM,Xilinx,Pulse,ON,Everlight and Freescale. Main products comprise IC,Modules,Potentiometer,IC Socket,Relay,Connector.Our parts cover such applications as commercial,industrial, and automotives areas.

We are looking forward to setting up business relationship with you and hope to provide you with the best service and solution. Let us make a better world for our industry!



Contact us

Tel: +86-755-8981 8866 Fax: +86-755-8427 6832

Email & Skype: info@chipsmall.com Web: www.chipsmall.com

Address: A1208, Overseas Decoration Building, #122 Zhenhua RD., Futian, Shenzhen, China



GTM - GRAPHICAL TANK MONITOR



- MONITORS THE LEVEL AND TEMPERATURE OF MULTIPLE TANKS
- BRIGHT COLOR DISPLAY SHOWS INFORMATION GRAPHICALLY
- HISTORICALLY TRENDS TEMPERATURE OVER TIME
- 100 POINT SCALING FOR NON-LINEAR (HORIZONTAL) TANK MEASUREMENT
- PASSWORD PROTECTED SETUP
- PROVIDES TWO LEVEL ALARMS PER TANK
- WEB SERVER ALLOWS ACCESS FROM ANY NETWORKED PC
- STANDARD ETHERNET AND SERIAL PORTS EXTEND CONNECTIVITY PLANTWIDE

GENERAL OVERVIEW

The GTM - Graphical Tank Monitor is a ready to use system for tank monitoring, complete with level and temperature indication. Also included are two level alarms per tank, allowing the GTM to prevent overflow, or to actuate other devices at predetermined levels.

The GTM accepts any two-wire, level sensor with a 4-20 mA output. Linear (vertical) tanks require only two point scaling, which can be performed either by keying in the current signal, or through the use of its built in learn mode. For nonlinear applications, such as horizontal tank measurement, up to 100 scaling points can be entered via the free Crimson software package. The GTM also accepts two, or three-wire, 100 Ohm platinum RTDs to monitor tank temperature. The trending feature allows an operator to look at a history of the temperature, similar to that of a chart-recorder.

The unit comes standard with Ethernet and RS485 ports, which allow unlimited connection possibilities to PCs, PLCs, and SCADA systems. As an option, Red Lion can configure the communications protocols, addresses, and memory map prior to shipment. The built-in web server allows users to view and control the GTM from any networked PC via standard web browser.

All standard programming is done via the bright 10.4" touchscreen. Critical parameters are protected by a programmable password, while often-changed values are accessible via an easy to use menu.

Enclosed in a stainless steel Hoffman Concept® cabinet designed specifically for the food and beverage industry, the GTM is suitable for use in demanding applications such as those found in the dairy and beverage markets.

SAFETY SUMMARY

All safety related regulations, local codes and instructions that appear in the manual or on equipment must be observed to ensure personal safety and to prevent damage to either the instrument or equipment connected to it. If equipment is used in a manner not specified by the manufacturer, the protection provided by the equipment may be impaired.

Do not use the controller to directly command motors, valves, or other actuators not equipped with safeguards. To do so can be potentially harmful to persons or equipment in the event of a fault to the controller.

ORDERING INFORMATION

MODEL NO.	DESCRIPTION	PART NUMBER
GTM	Graphical Level/Temperature Monitor, 10.4" Display, 8 Tank	GTM10080
	Graphical Level/Temperature Monitor, 10.4" Display, 8 Tank, with preconfigured communications parameters	GTM1008S

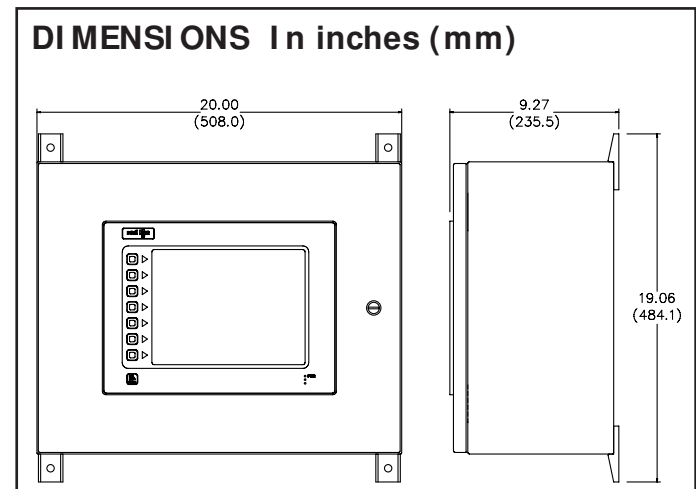



CAUTION: Read complete instructions prior to installation and operation of the unit.



CAUTION: Risk of electric shock.

GENERAL SPECIFICATIONS

1. POWER REQUIREMENTS: 100-240 VAC/DC @ 60 W

- Fuse: 1 amp slow-blow preinstalled
- One spare fuse included (stored in fuse terminal)
- Type: 1/4 x 1 1/4 inch (6.3 x 32 mm) slow-blow, glass

2. DISPLAY: 10.4" TFT resistive touchscreen, 640 x 480 VGA, 256 colors

3. LEVEL INPUTS:

- Channels: accepts eight (8) two-wire sensor inputs
- Type: 4-20 mA
- Effective Resolution: Full 16-bit
- Linearizer: 100 Points (Crimson software required for linearization setup)
- Sample Time: 400 msec
- Common Mode Rejection: >110 dB, 50/60 Hz
- Normal Mode Rejection: >90 dB, 50/60 Hz
- Step Response Time: One scan time (to within 99% of final value)
- Input Impedance: 10 Ω
- Max. Continuous Overload: 100 mA
- Accuracy: $\pm 0.1\%$ of span
- Input Fault Response: Upscale Drive

4. TEMPERATURE INPUTS:

- Channels: accepts eight (8) two or three-wire RTDs
- Type: 100 Ohm platinum RTD, 0.00385 coefficient
- Effective Resolution: Full 16-bit
- Sample Time: 400 msec.
- Common Mode Rejection: >110 dB, 50/60 Hz
- Normal Mode Rejection: >90 dB, 50/60 Hz
- Temperature Coefficient: 0.01%/°C
- Step Response Time: One scan time (to within 99% of final value)
- Excitation: 150 μ A
- Lead Resistance: 15 Ω Max
- Resolution: 0.1°

Accuracy: $\pm (0.1\%$ of span) over 18 to 28°C environment, $\pm (0.2\%$ of span) over 0 to 42°C environment. Includes NIST conformity, A/D conversion errors, temperature coefficient and linearization conformity at 23°C after 20 minute warm up.

Probe break response: Upscale Drive

5. ALARM OUTPUTS:

- Channels: 16 (two outputs per tank)
- Action: High acting, automatic reset upon correction of alarm condition
- Type: N.O. (Form A) relay
- Isolation: Each pair of relays for a given tank share the common terminal
- Current Rating by pair: 3 Amps @ 30 VDC / 125 VAC resistive 1/10 HP @ 125 VAC
- Life Expectancy: 200,000 cycles at maximum load rating. (Decreasing load, increasing cycle time, and use of surge suppression such as RC snubbers increases life expectancy.)

6. CONNECTIONS: Cage-clamp terminal blocks

- Power:
 - Wire Gage: 26-10 AWG copper wire
- Input/Output:
 - Wire Gage: 24-12 AWG copper wire

7. ENVIRONMENTAL CONDITIONS:

- Operating Temperature Range: 0 to 42°C
- Storage Temperature Range: -40 to 80°C
- Operating and Storage Humidity: 80% max relative humidity, (non-condensing)
- Altitude: Up to 2000 meters

8. PHYSICAL CONSTRUCTION: NEMA 4X/IP65 HMI is enclosed in a stainless steel Hoffman Concept® enclosure designed to meet the requirements for the food and beverage industry.

9. WEIGHT: 55 lbs (24.9 kg)

INSTALLATION

MOUNTING

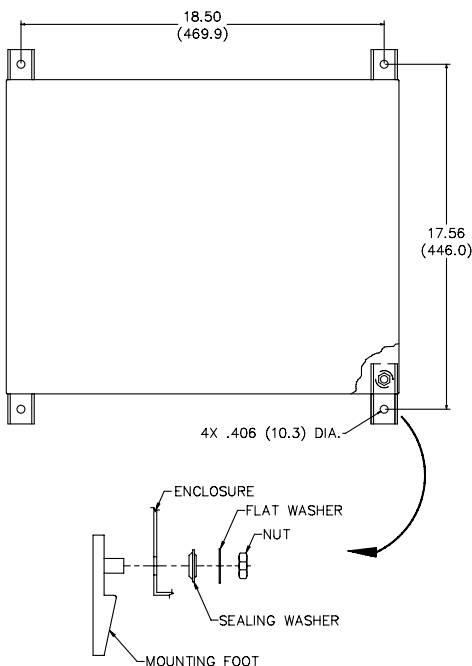

MOUNTING FEET INSTALLATION

1. Insert mounting foot studs into drilled holes and turn enclosure upright.
2. Press sealing washer onto mounting foot stud with the tapered cone towards the hole and add flat washer.
3. Thread nut onto mounting foot stud and tighten to 200 in-lbs.
4. Make sure that the bolts and anchors used to attach the GTM to the wall can hold at least 50 pounds each.

CONDUIT

The GTM's enclosure was designed without conduit entries to allow you to place them in the best location for your application. When determining the best entry points, ensure that standard wiring practices are taken into consideration. This includes the following...

1. To reduce the chance of noise spikes entering the unit via the power lines, connections should be made to a clean source. Connecting to circuits that also power loads such as contactors, relays, motors, solenoids, etc. should be avoided.
2. The unit should be properly earth grounded via the ground terminal.
3. Use shielded (screened) cables for all Level and RTD Signal inputs. The shield (screen) pigtail connection should be made as short as possible. The connection point for the shield depends somewhat upon the application. Listed below are the recommended methods of connecting the shield, in order of their effectiveness.
 - a. Connect the shield to earth ground (protective earth) at one end where the unit is mounted.
 - b. Connect the shield to earth ground at both ends of the cable, usually when the noise source frequency is over 1 MHz.
4. Avoid running the Level and RTD Signal cables in the same conduit with the Power and Output cables. Also, the Level and Signal cables should be routed as far away as possible from contactors, control relays, transformers, and other noisy components.
5. Avoid running the Output cables near the electronics at the top of the enclosure, particularly if switching inductive loads such as relays, motors, solenoids, etc.

Note: Metal chips created while drilling should not be permitted to fall into the equipment. To ensure that this does not happen, you can temporarily remove the sub-panel to which the electronics are mounted. (See Electrical Overview diagram.)

ELECTRICAL OVERVIEW

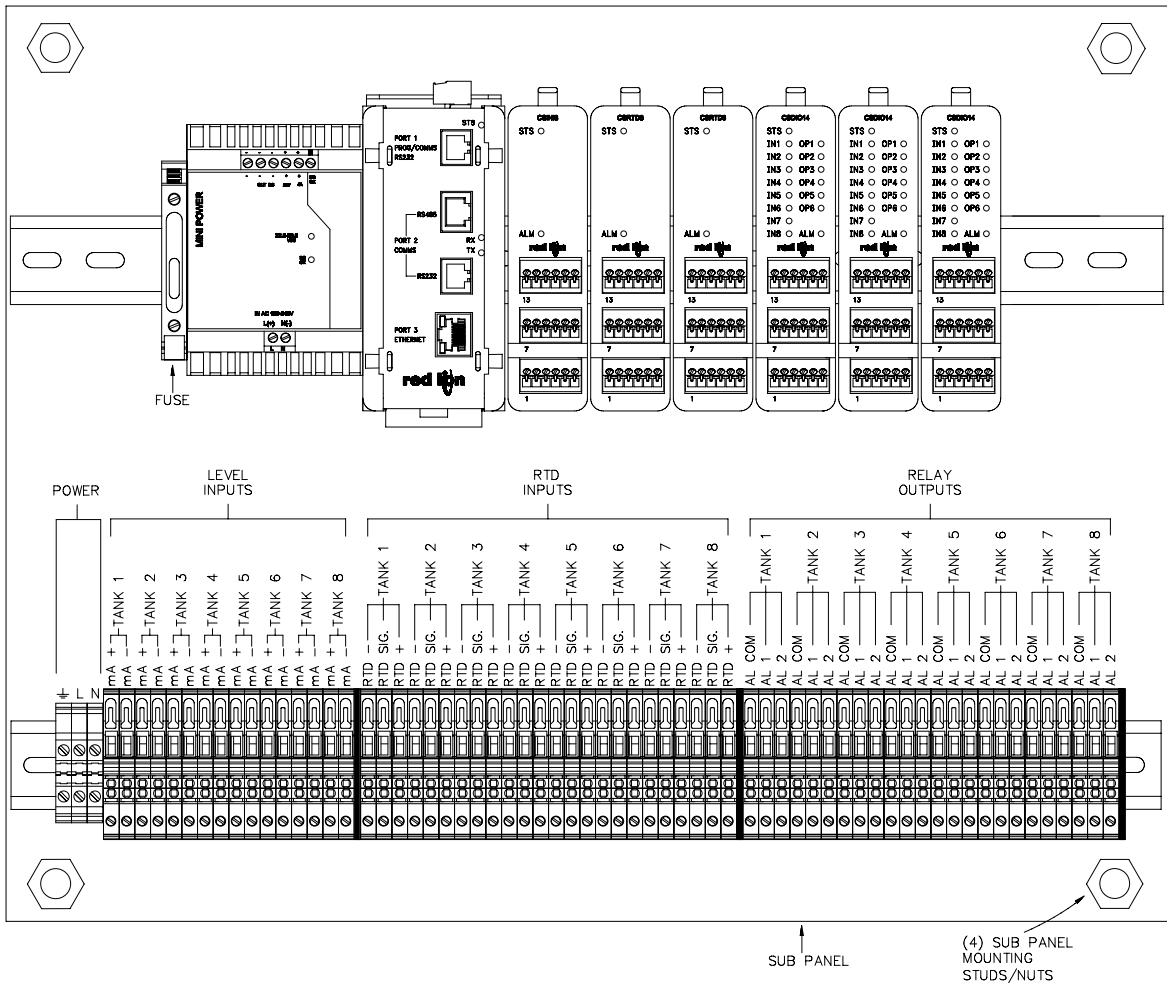

WIRING

All field wiring is terminated at terminal blocks on lower rail.

POWER

The GTM can be powered with 100-240 VAC or DC @ 60 W.

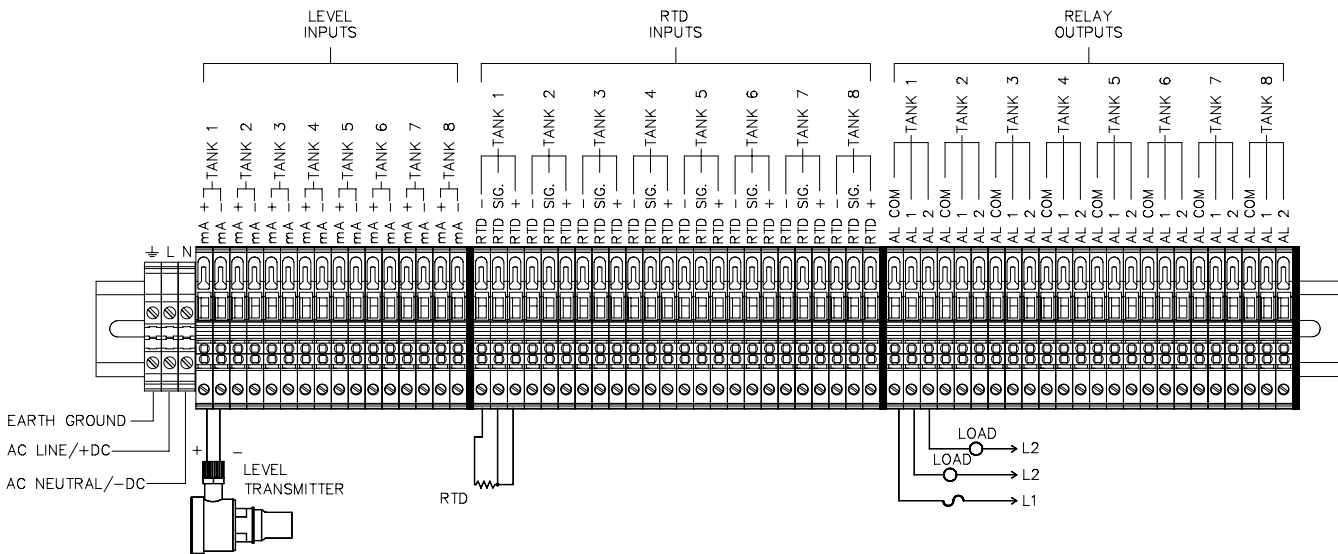

SETUP

See GTM Operator's Manual for setup and operation.

LIMITED WARRANTY

The Company warrants the products it manufactures against defects in materials and workmanship for a period limited to one year from the date of shipment, provided the products have been stored, handled, installed, and used under proper conditions. The Company's liability under this limited warranty shall extend only to the repair or replacement of a defective product, at The Company's option. The Company disclaims all liability for any affirmation, promise or representation with respect to the products.

The customer agrees to hold Red Lion Controls harmless from, defend, and indemnify RLC against damages, claims, and expenses arising out of subsequent sales of RLC products or products containing components manufactured by RLC and based upon personal injuries, deaths, property damage, lost profits, and other matters which Buyer, its employees, or sub-contractors are or may be to any extent liable, including without limitation penalties imposed by the Consumer Product Safety Act (P.L. 92-573) and liability imposed upon any person pursuant to the Magnuson-Moss Warranty Act (P.L. 93-637), as now in effect or as amended hereafter.

No warranties expressed or implied are created with respect to The Company's products except those expressly contained herein. The Customer acknowledges the disclaimers and limitations contained herein and relies on no other warranties or affirmations.

Red Lion Controls
20 Willow Springs Circle
York PA 17402
Tel +1 (717) 767-6511
Fax +1 (717) 764-0839

Red Lion Controls BV
Basicweg 11b
NL - 3821 BR Amersfoort
Tel +31 (0) 334 723 225
Fax +31 (0) 334 893 793

Red Lion Controls AP
31, Kaki Bukit Road 3,
06-04/05 TechLink
Singapore 417818
Tel +65 6744-6613
Fax +65 6743-3360