



Chipsmall Limited consists of a professional team with an average of over 10 year of expertise in the distribution of electronic components. Based in Hongkong, we have already established firm and mutual-benefit business relationships with customers from,Europe,America and south Asia,supplying obsolete and hard-to-find components to meet their specific needs.

With the principle of “Quality Parts,Customers Priority,Honest Operation,and Considerate Service”,our business mainly focus on the distribution of electronic components. Line cards we deal with include Microchip,ALPS,ROHM,Xilinx,Pulse,ON,Everlight and Freescale. Main products comprise IC,Modules,Potentiometer,IC Socket,Relay,Connector.Our parts cover such applications as commercial,industrial, and automotives areas.

We are looking forward to setting up business relationship with you and hope to provide you with the best service and solution. Let us make a better world for our industry!



Contact us

Tel: +86-755-8981 8866 Fax: +86-755-8427 6832

Email & Skype: info@chipsmall.com Web: www.chipsmall.com

Address: A1208, Overseas Decoration Building, #122 Zhenhua RD., Futian, Shenzhen, China



PANDUIT TOOL NO.	INSTALLS * THE FOLLOWING CABLE TIE CROSS-SECTION **	WEIGHT/PC	
		OZ	GRAMS
GTS-E	SM,M,I,S	10.4	294

(A)

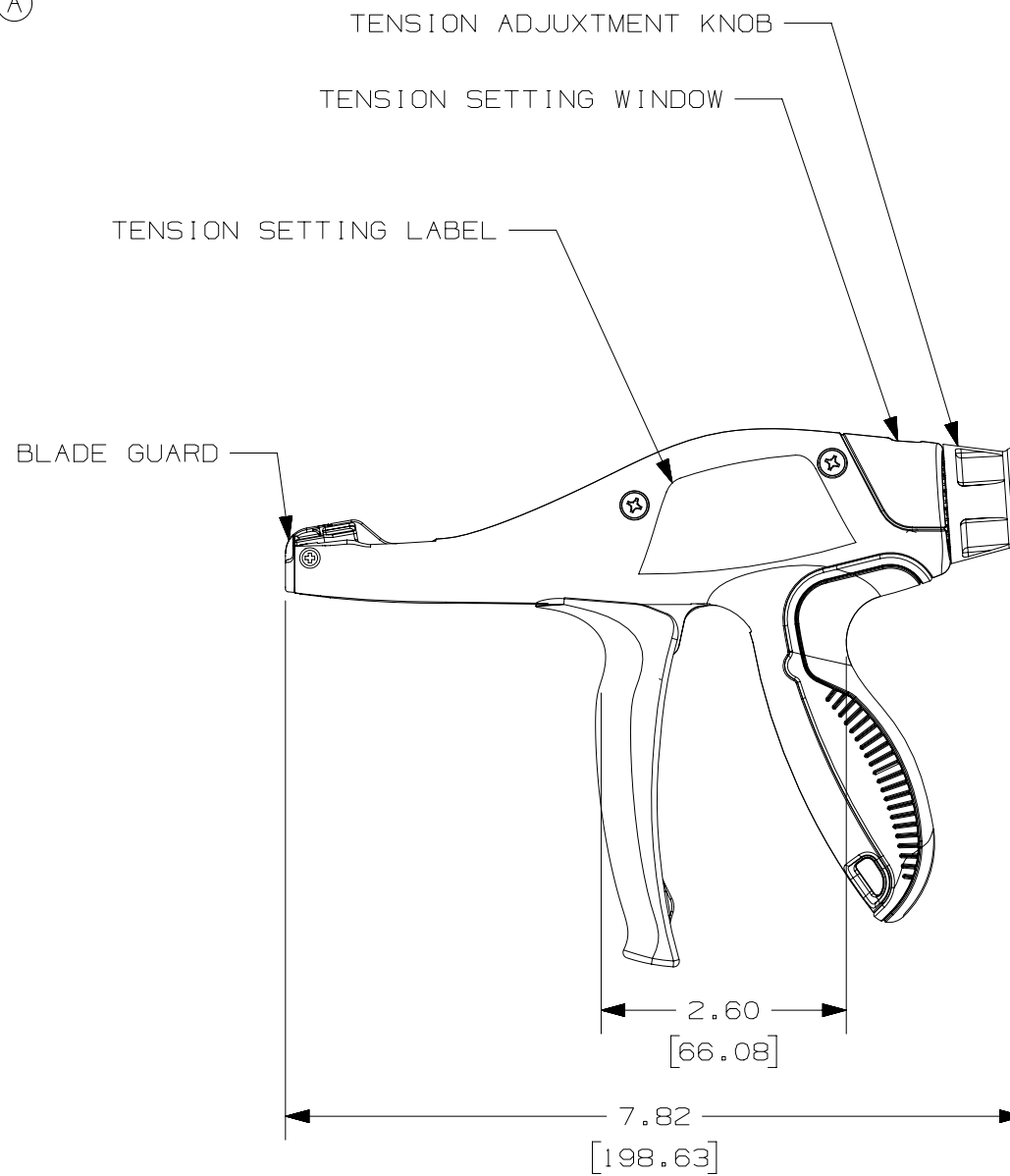
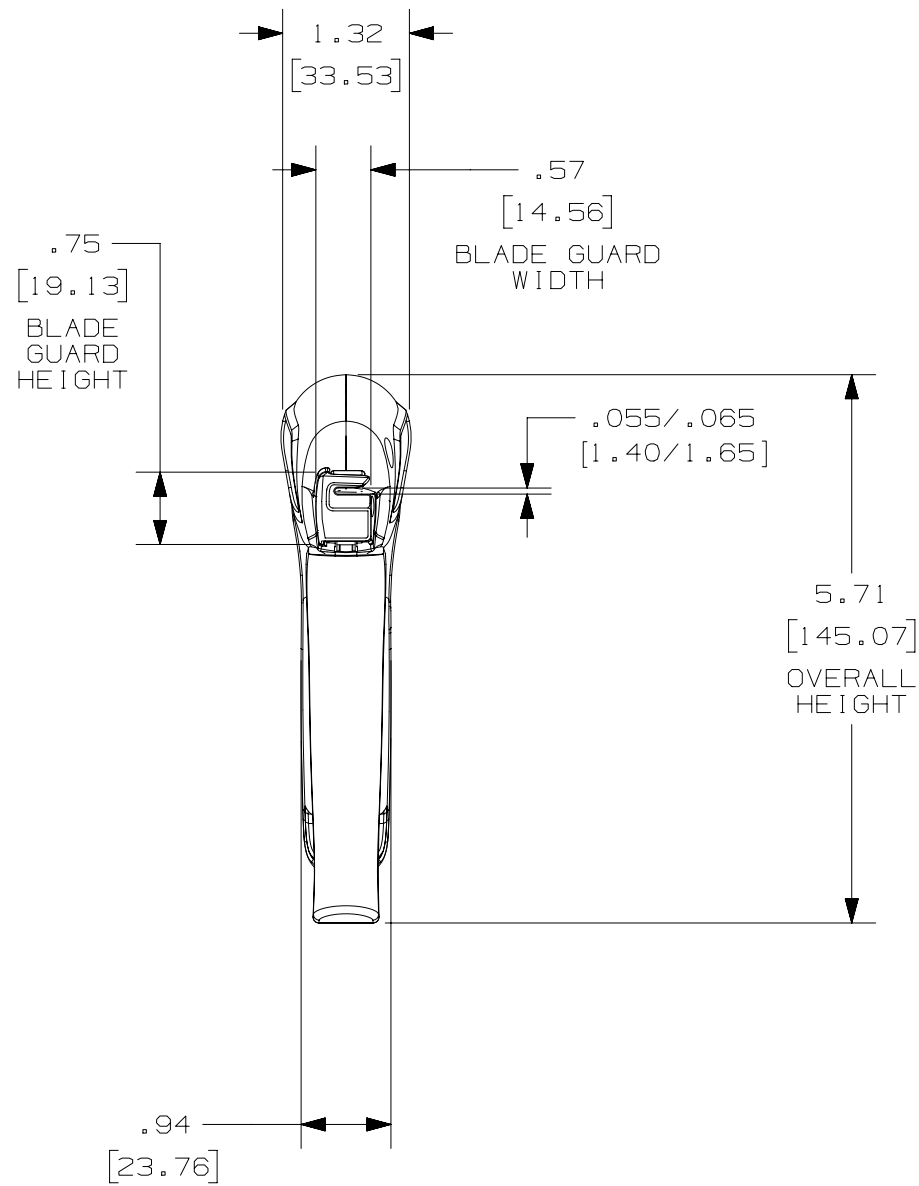

NOTES, UNLESS OTHERWISE SPECIFIED:

RoHS COMPLIANT.

* THIS TOOL TIGHTENS CABLE TIES AND CUTS OFF EXCESS PORTION WHEN PRESET TENSION IS ATTAINED.

** CABLE TIE CROSS-SECTION CODE:
 SM = SUB-MINIATURE
 M = MINIATURE
 I = INTERMEDIATE
 S = STANDARD.

DIMENSIONS IN BRACKETS ARE METRIC.

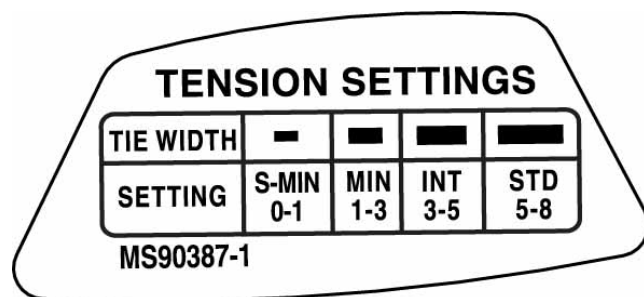

(B)

REV	DATE	BY	CHK	APR	DESCRIPTION	ECN
03	9-7-16	JEH	ABJ	JADE	ADDED: (B) MIL SPEC NUMBER TO THE LABEL	10636
02	10-29-15	JEH	ABJ	ABJ	WAS: (A) 10.49 oz 298.2 GRAMS	4769
01	8-26-15	JEH	ABJ	ABJ	ADDED TENSION LABEL VIEW	4769
00	1-26-15	JEH	ABJ	ABJ	RELEASED	4769

TITLE		CD, GTS-E	
ITEM REVISION NAME		Customer/Military Drawing	
DATASET FILE NAME		R27575AA/03	
DRAWING NUMBER:		WB27575B01	
MATERIAL:		-	
UNLESS OTHERWISE SPECIFIED, DIMENSIONAL TOLERANCES ARE: IN [mm]		.x ± .1 [2.54] .xxx ± .005 [.127]	
.xx ± .01 [.25] ANGLES ± 5°		THIRD ANGLE PROJECTION	
DRAWN BY	DATE	CHK	SCALE
JEH	1-26-15	ABJ	1:2
SHT 1 OF 1			SIZE B