



Chipsmall Limited consists of a professional team with an average of over 10 year of expertise in the distribution of electronic components. Based in Hongkong, we have already established firm and mutual-benefit business relationships with customers from,Europe,America and south Asia,supplying obsolete and hard-to-find components to meet their specific needs.

With the principle of “Quality Parts,Customers Priority,Honest Operation,and Considerate Service”,our business mainly focus on the distribution of electronic components. Line cards we deal with include Microchip,ALPS,ROHM,Xilinx,Pulse,ON,Everlight and Freescale. Main products comprise IC,Modules,Potentiometer,IC Socket,Relay,Connector.Our parts cover such applications as commercial,industrial, and automotives areas.

We are looking forward to setting up business relationship with you and hope to provide you with the best service and solution. Let us make a better world for our industry!



## Contact us



Tel: +86-755-8981 8866 Fax: +86-755-8427 6832

Email & Skype: info@chipsmall.com Web: www.chipsmall.com

Address: A1208, Overseas Decoration Building, #122 Zhenhua RD., Futian, Shenzhen, China

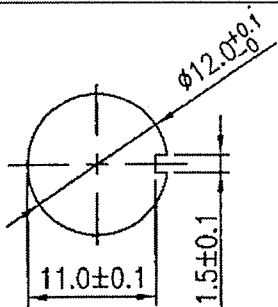
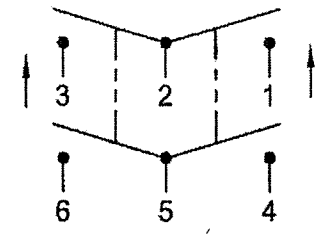

THIS INFORMATION IS CONFIDENTIAL AND PROPRIETARY TO CW INDUSTRIES INCORPORATED AND ITS AFFILIATES. IT MAY NOT BE DISCLOSED TO ANYONE, OTHER THAN CW INDUSTRIES PERSONNEL, WITHOUT WRITTEN AUTHORIZATION FROM CW INDUSTRIES INCORPORATED, SOUTHAMPTON, PENNSYLVANIA USA.

Ratings		12 (4) A 250V AC			Mounting Hole	Circuit
Contact Resistance	50m ohm max.					
Insulation Resistance	DC 500V 100M ohm Min.					
Dielectric Strength	AC 1500V 1 minute					
Operation Temperature	0° C ~ 85° C					
Switch Function	6P DPDT (ON) - OFF - (ON)					

( ) = Momentary Function

**MATERIAL:**

Frame: Nylon 6/6, Black  
 UL Flame: 94-V0  
 Lever: Metal  
 Terminal: Copper Alloy

Water proof and Dust Proof  
 to fit IP-56

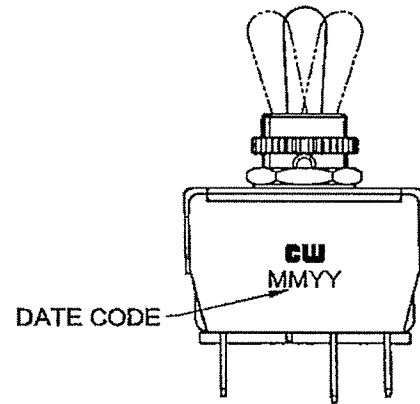
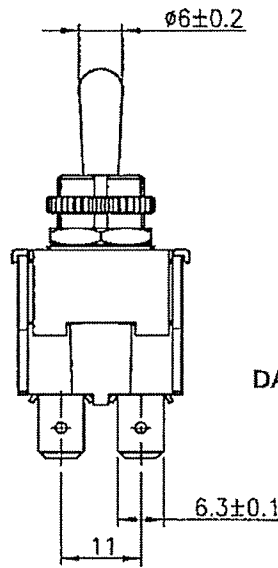
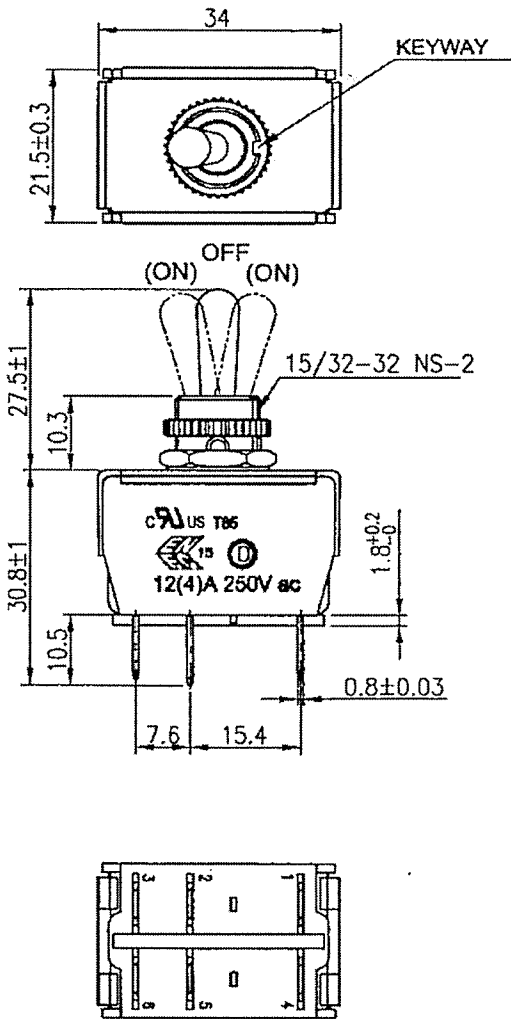

Tolerances Unless Otherwise Specified +/-0.5.

RoHS Compliant

6 Updated material notes & views. 3-21-13.

**CW INDUSTRIES**  
 Southampton, Pa. 18966  
 Tel 215.355.7080/www.cwind.com

Date Drawn: 1/28/11

Rev. 6

Unit: mm

Checked By: *G. Guld*

Title: **TOGGLE SWITCH**

CW P/N: **GTS448K101AHR**