



Chipsmall Limited consists of a professional team with an average of over 10 year of expertise in the distribution of electronic components. Based in Hongkong, we have already established firm and mutual-benefit business relationships with customers from,Europe,America and south Asia,supplying obsolete and hard-to-find components to meet their specific needs.

With the principle of “Quality Parts,Customers Priority,Honest Operation,and Considerate Service”,our business mainly focus on the distribution of electronic components. Line cards we deal with include Microchip,ALPS,ROHM,Xilinx,Pulse,ON,Everlight and Freescale. Main products comprise IC,Modules,Potentiometer,IC Socket,Relay,Connector.Our parts cover such applications as commercial,industrial, and automotives areas.

We are looking forward to setting up business relationship with you and hope to provide you with the best service and solution. Let us make a better world for our industry!



## Contact us

Tel: +86-755-8981 8866 Fax: +86-755-8427 6832

Email & Skype: info@chipsmall.com Web: www.chipsmall.com

Address: A1208, Overseas Decoration Building, #122 Zhenhua RD., Futian, Shenzhen, China





*RoHS compliant*

## Ethernet Serial Server

■ ■ GW51C-MAXI

- 1-port DIN-Rail model (IP50 Standard)
- Selectable RS-232/422/485 serial interface (15 KV ESD protection)
- 10/100Mbps Fast Ethernet full duplex auto negotiation
- Support with TCP Server/Client, UDP and Virtual COM mode
- Configurable via serial console, Telnet, Web server, or Windows based utilities
- Upgradeable firmware via network

The Industrial Serial Server GW51C-MAXI is a gateway between Ethernet (TCP/IP) and RS-232/422/485 communications. It allows almost any serial device to be connected to a new or existing Ethernet network.

By encapsulating serial data and transporting it over Ethernet, GW51C-MAXI offers full-duplex, bi-directional data transmission transparent between serial port and Ethernet network.

In industrial and manufacturing automation fields, GW51C-MAXI is used as a field device to connect Ethernet through TCP/IP protocol directly. It is also specially designed for conjunction with PLCs, HMIs, Barcode Scanners, Data Terminals, Electronic Kanbans, Shop Floor Control Systems, and Pick-to-Light Systems.

Terminal Server (main control program executed in this unit) makes most use of Ethernet connectivity to drive serial devices. It transforms whatever serial data received to TCP/UDP format then enables a host computer to drive the serial devices through the Ethernet.

Atop Virtual COM software provides existing Windows based applications to access serial-Ethernet devices by mapping to remote serial server over Ethernet.

Flexible configuration options enable this unit to be setup over Ethernet by Telnet, web browser, serial console, or other Windows utilities. Packed in a rugged metal housing with DIN Rail-mountable case and 9~30VDC wide power input range, GW51C-MAXI is ideal for almost any industrial and manufacturing automation.

# Industrial Serial Server



## Specifications

System	
CPU	16-bit x86 Embedded CPU
Flash	512 KBytes
RAM	512 KBytes SDRAM
EEPROM	512 Bytes
Watchdog	Hardware built-in
Ethernet	
Compliance	IEEE802.3
Port	1-port
Transmission Rate	10/100Mbps Auto-detection
Connector	RJ-45
Auto MDI/MDI-X	No
Link Mode	
TCP Server	Up to 4 connections or Virtual Com mode
TCP Client	Single destination
UDP	Single destination
Serial	
Interface	RS-232/422/485 switch selectable
Ports	1-port
Baud Rate	1200bps~230Kbps
Parity	None, Odd, Even, Mark, Space
Data Bits	7, 8
Stop Bits	1, 2
Flow Control	None, Software: Xon/Xoff, Hardware: RTS/CTS
Connector	5-pin 5.08mm terminal block / 8-pin Mini DIN
Protection	15KV ESD
Power	
Input	DC 9 ~ 30V
Consumption	Max. 2.8W
Environment	
Operating	0°C~60°C
Storage	-40° ~ 85°C ( -40°~ 185°F ), 5 ~ 95%RH
Dimension	
W x H x D	45mm x 91mm x 80mm
Software	
Configuration	Web Page / Telnet / Serial console / Windows utility
Virtual Com	Windows port redirection software
Support Protocol	ICMP, TCP(UDP) / IP, DHCP client, SNMP, SMTP, HTTP, Telnet
Ordering Information	
GW51C-MAXI-WDT	1-port switch selectable RS-232/422/485 (Terminal Block) serial server

## TCP Server Mode

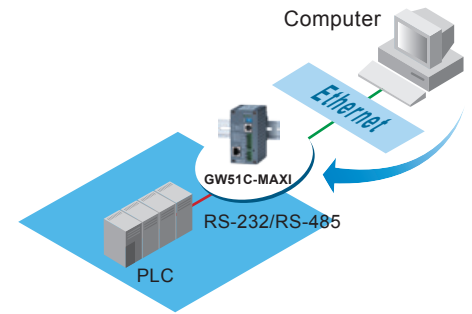

## TCP Client mode

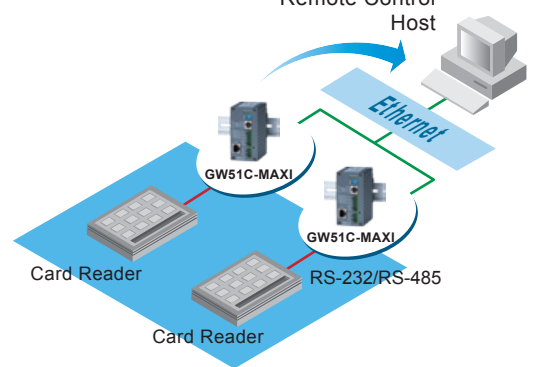

## UDP mode

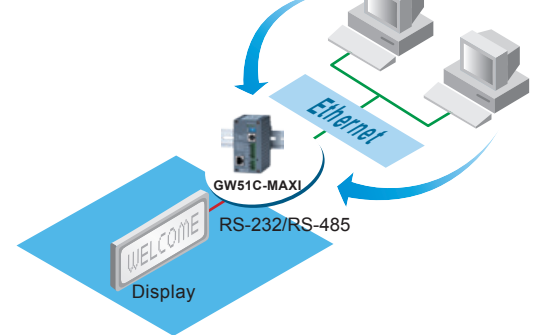

## Tunneling mode

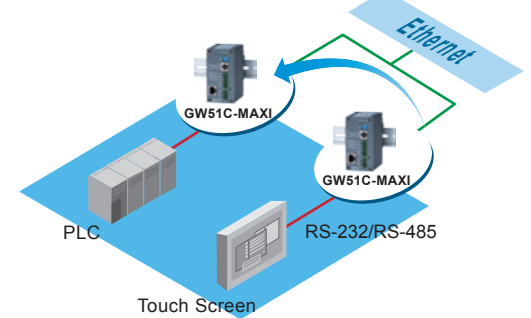

## GW51C-MAXI Front Panel

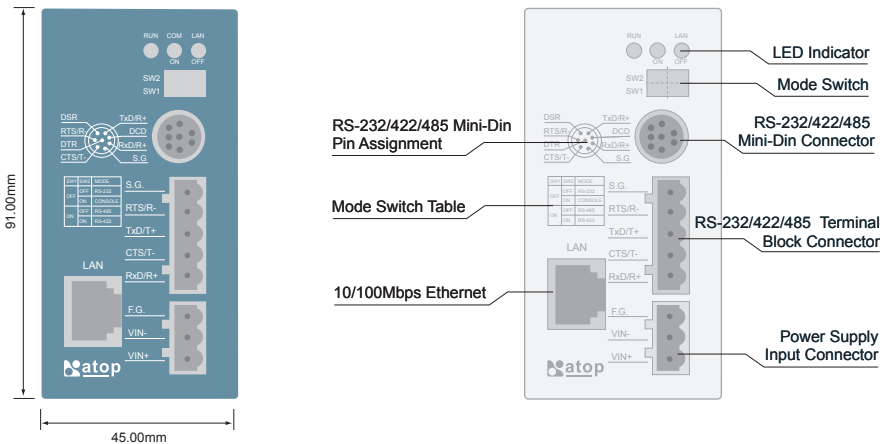

## Atop Technologies, Inc.

TEL : +886-3-5508137  
 FAX : +886-3-5508131  
 sales@atop.com.tw  
 http : //www.atop.com.tw

Design and specification are subject to change without notice.  
 All product names referenced herein are registered trademarks of their respective companies.



CA\_GW51C-MAXI\_E : v2-040730