



Chipsmall Limited consists of a professional team with an average of over 10 year of expertise in the distribution of electronic components. Based in Hongkong, we have already established firm and mutual-benefit business relationships with customers from,Europe,America and south Asia,supplying obsolete and hard-to-find components to meet their specific needs.

With the principle of “Quality Parts,Customers Priority,Honest Operation,and Considerate Service”,our business mainly focus on the distribution of electronic components. Line cards we deal with include Microchip,ALPS,ROHM,Xilinx,Pulse,ON,Everlight and Freescale. Main products comprise IC,Modules,Potentiometer,IC Socket,Relay,Connector.Our parts cover such applications as commercial,industrial, and automotives areas.

We are looking forward to setting up business relationship with you and hope to provide you with the best service and solution. Let us make a better world for our industry!



## Contact us

Tel: +86-755-8981 8866 Fax: +86-755-8427 6832

Email & Skype: info@chipsmall.com Web: www.chipsmall.com

Address: A1208, Overseas Decoration Building, #122 Zhenhua RD., Futian, Shenzhen, China



# PART NUMBER CODING

## G E DHRQ-T941

REVISIONS				
REV.	ECO. NO	DESCRIPTION	DATE	BY
E	2536	UPDATE PROCESSING FOR "N" MTL	3/30/2012	JH
F	2740	REMOVE 'NYLON 46' MATERIAL OPTION	04/24/2013	LH
H	3463	ADD NOTE 15	06/06/2016	LH

### PLATING POSITIONS

CONTACT SURFACE	TERMINATION	POSITIONS
W = GOLD FLASH	.000100" PURE TIN, MATTE	18
B = .000010" GOLD	.000100" PURE TIN, MATTE	32
C = .000030" GOLD	.000100" PURE TIN, MATTE	49
		82

(ALL PLATINGS ARE LEAD FREE AND HAVE .000050" MIN NICKEL UNDERPLATE)

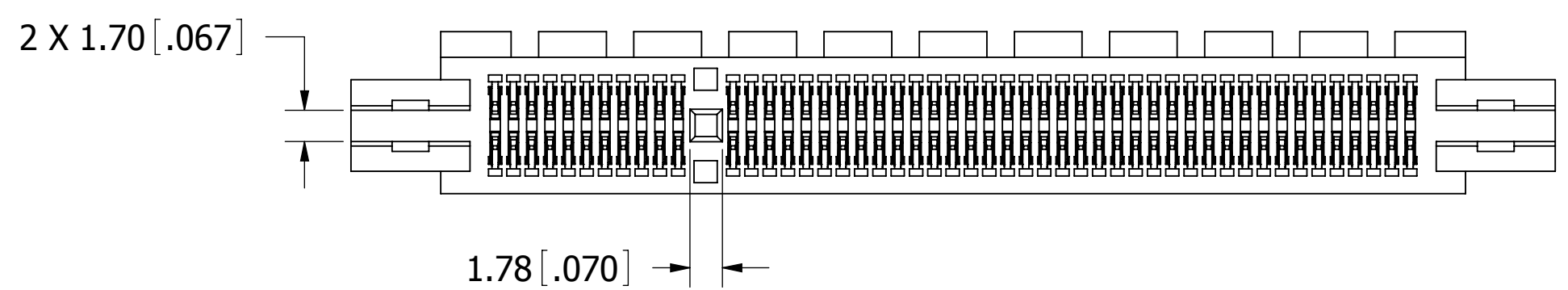
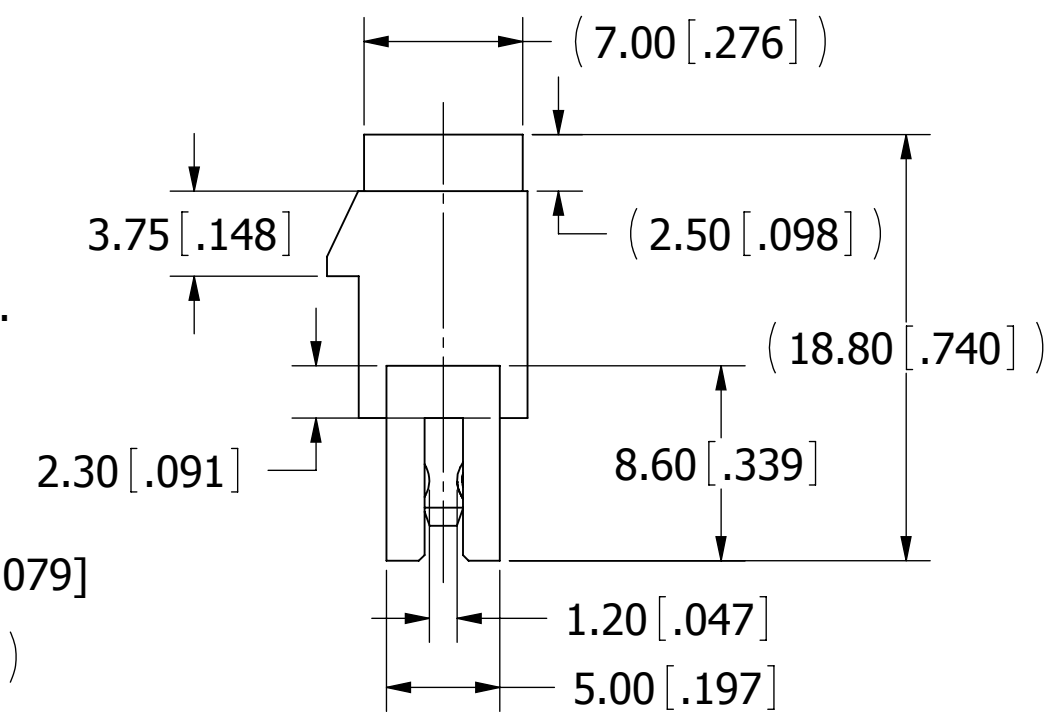
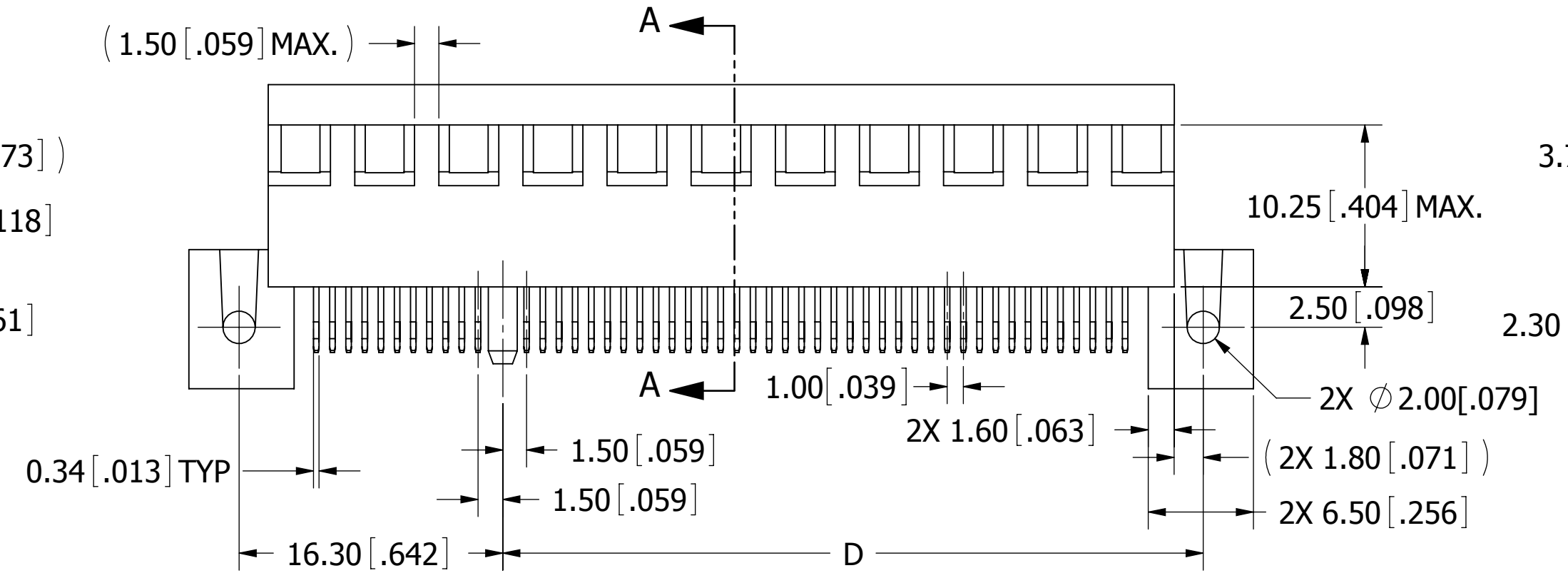
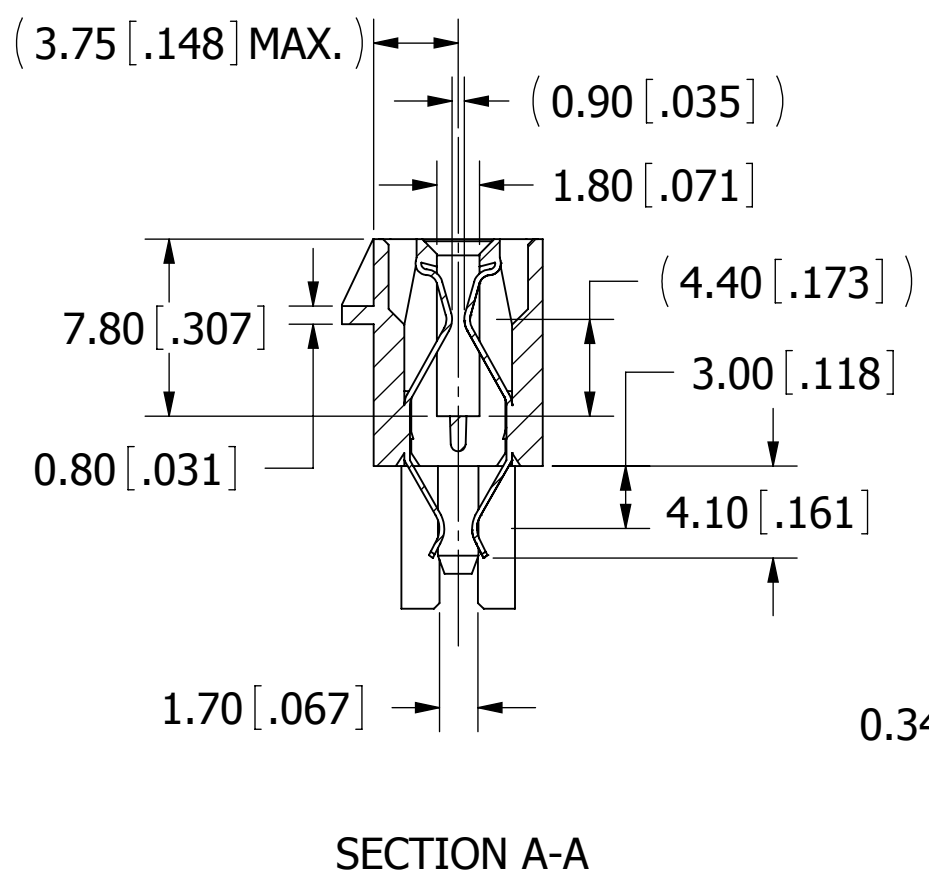
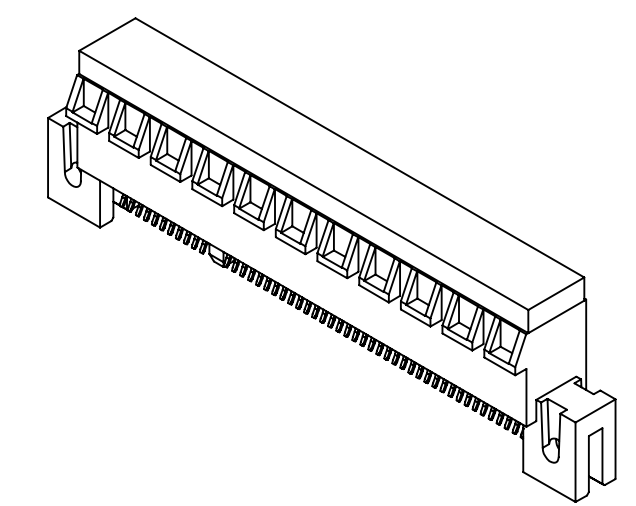
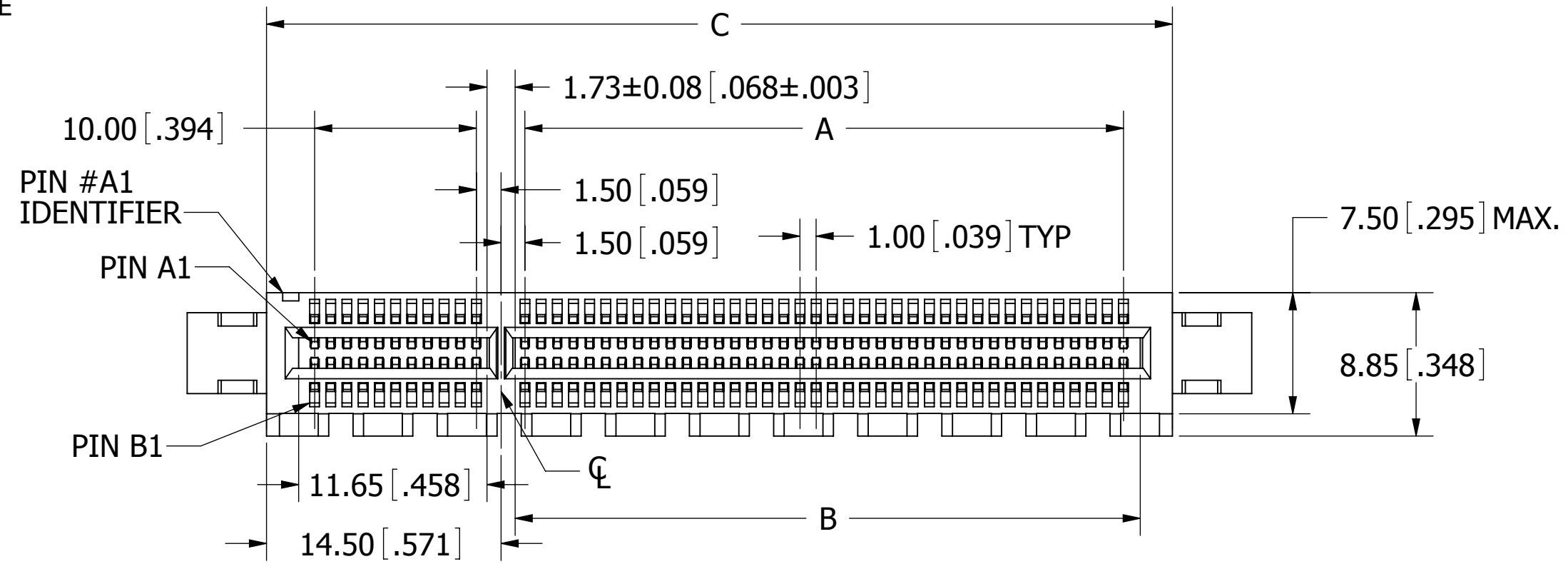

- NOTES:
- INSULATOR MATERIAL: NYLON 9T, UL 94V-0, COLOR: BLACK.
  - CONTACT MATERIAL: PHOSPHOR BRONZE.
  - CONTACT PLATING: SEE PART NUMBER CODING.
  - CURRENT RATING: 1.1 AMPS PER CONTACT.
  - VOLTAGE RATING: 50 VAC/DC.
  - INSULATOR RESISTANCE: 1000 MEGOHMS MIN.
  - CONTACT RESISTANCE: 30 MILLI OHMS MAX.
  - DIELECTRIC WITHSTANDING: 500 VAC.
  - OPERATING TEMP.: -10°C TO + 85°C.
  - PROCESSING TEMP.: 260°C FOR 10 SEC. MAX.
  - BOARD THICKNESS ACCOMMODATED: 1.57mm±0.13[.062±.005]
  - INSERTION FORCE: 117.3g(1.173 N) MAX PER CONTACT PAIR USING A 1.70mm (.067") STEEL CARD.
  - WITHDRAWAL FORCE: 15.31g(0.153 N) MIN PER CONTACT PAIR USING A 1.44mm (.057") STEEL CARD.
  - CAP NEEDS TO BE ON DURING IR REFLOW PROCESS TO PREVENT WARPAGE.
  - MATERIAL CODE "N" EQUIVALENT TO "G".

PART NUMBER	POSITIONS/ CONTACTS	A		B		C		D	
		MM	[INCH]	MM	[INCH]	MM	[INCH]	MM	[INCH]
G_E18DHRQ-T941	18/36	6.00	0.236	7.65	0.301	25.00	0.984	12.30	0.484
G_E32DHRQ-T941	32/64	20.00	0.787	21.65	0.852	39.00	1.535	26.30	1.035
G_E49DHRQ-T941	49/98	37.00	1.457	38.65	1.522	56.00	2.205	43.30	1.705
G_E82DHRQ-T941	82/164	70.00	2.756	71.65	2.821	89.00	3.504	76.30	3.004



UNLESS OTHERWISE SPECIFIED:  
DIMENSIONS ARE IN MM[INCHES]

TOLERANCES:

ANGULAR: ± 3°

.X± .35 [.014]  
.XX± .25 [.010]  
.XXX± .080 [.0031]

DRAWN	DATE	NAME	
	07/07/09	JH	
<small>THE INFORMATION HEREIN CONTAINS PROPRIETARY INFORMATION OF SULLINS ELECTRONICS AND IS NOT TO BE REPRODUCED, USED OR DISCLOSED TO OTHERS FOR ANY PURPOSE EXCEPT AS SPECIFICALLY AUTHORIZED IN WRITING BY AN OFFICER OF SULLINS ELECTRONICS.</small>			<b>TITLE</b> PCI E, 1.00mm[.039"] CC, STRADDLE, CLIPS
<b>PART NUMBER</b> G_E_DHRQ-T941			<b>SIZE</b> C
<b>CAGE CODE</b> 54453		<b>DWG. NO.</b> 11042	<b>REV</b> H
<b>SCALE:</b> 2:1			SHEET 1 OF 2

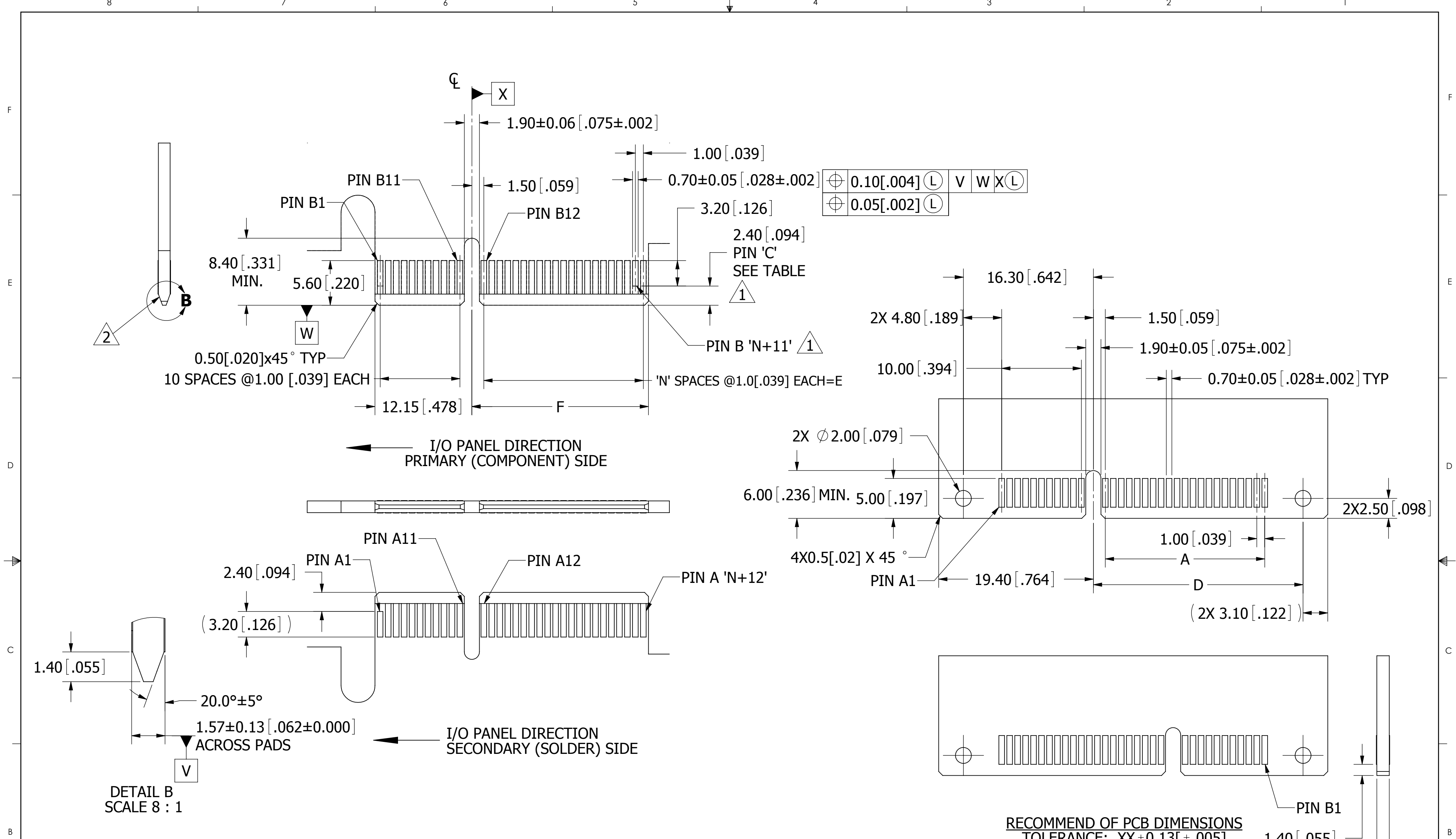

⊕ 0.10 [.004] (L)	V	W	X (L)
⊕ 0.05 [.002] (L)			

- NO TIE BAR PERMITTED FROM CARD EDGE TO LEADING EDGE OF PAD FOR PINS A1 AND 'C'.
- CHAMFER EDGE MUST BE FREE OF CUTTING BURRS.

POSITIONS/ CONTACT	DAUGHTER CARD LAYOUT					
	SPACES 'N'	E		F		PIN 'C'
		MM	[INCH]	MM	[INCH]	
18/36	6	6.00	0.236	8.15	0.321	B17
32/64	20	20.00	0.787	22.15	0.872	B31
49/98	37	37.00	1.457	39.15	1.541	B48
82/164	70	70.00	2.756	72.15	2.841	B81

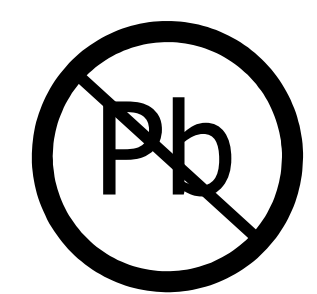

RoHS COMPLIANT

UNLESS OTHERWISE SPECIFIED: DIMENSIONS ARE IN MM[INCHES]	DRAWN	DATE	NAME	
		07/07/09	JH	
TOLERANCES: ANGULAR: ± 3°  .X = ± .35 [.014] .XX = ± .25 [.010] .XXX = ± .080 [.0031]	<small>THE INFORMATION HEREIN CONTAINS PROPRIETARY INFORMATION OF SULLINS ELECTRONICS AND IS NOT TO BE REPRODUCED, USED OR DISCLOSED TO OTHERS FOR ANY PURPOSE EXCEPT AS SPECIFICALLY AUTHORIZED IN WRITING BY AN OFFICER OF SULLINS ELECTRONICS.</small>			TITLE
				PCI E, 1.00mm [.039"] CC, STRADDLE, CLIPS
PART NUMBER				G_E_DHRQ-T941
SIZE	CAGE CODE	DWG. NO.	REV	
C	54453	11042	H	
SCALE: 2:1		SHEET 2 OF 2		