



Chipsmall Limited consists of a professional team with an average of over 10 year of expertise in the distribution of electronic components. Based in Hongkong, we have already established firm and mutual-benefit business relationships with customers from,Europe,America and south Asia,supplying obsolete and hard-to-find components to meet their specific needs.

With the principle of “Quality Parts,Customers Priority,Honest Operation,and Considerate Service”,our business mainly focus on the distribution of electronic components. Line cards we deal with include Microchip,ALPS,ROHM,Xilinx,Pulse,ON,Everlight and Freescale. Main products comprise IC,Modules,Potentiometer,IC Socket,Relay,Connector.Our parts cover such applications as commercial,industrial, and automotives areas.

We are looking forward to setting up business relationship with you and hope to provide you with the best service and solution. Let us make a better world for our industry!



Contact us

Tel: +86-755-8981 8866 Fax: +86-755-8427 6832

Email & Skype: info@chipsmall.com Web: www.chipsmall.com

Address: A1208, Overseas Decoration Building, #122 Zhenhua RD., Futian, Shenzhen, China



Dual 20V N-Channel Power MOSFET

GWS9294

The GWS9294 is a dual 20V, 12mΩ, N-channel power MOSFET used for Li-ion battery protection. It is offered in a 2mmx2mm MLPD with a very low thickness profile, 1mm maximum thickness. The device has extremely high power density, reducing the board size of the Li-ion battery power system. Designed for handheld devices with a high level of ESD protection.

Features

- Monolithic dual MOSFET
- Low $r_{DS(ON)}$ in a small footprint
- Ultra low gate charge and figure of merit
- MLPD 2mmx2mm package
- Low thermal resistance

Applications

- Li-ion battery protection
- Portable devices, cell phones, PDA
- Rated for short-circuit and overcurrent protection
- Integrated gate diodes provide ESD protection of 2.5kV HBM

PRODUCT SUMMARY

$V_{(BR)DSS}$	$I_D = 250\mu A$	20V	Minimum
$r_{DS(ON)}$	$V_{GS} = 4.5V$	12mΩ	Typical

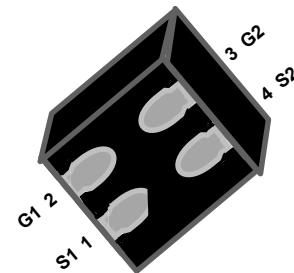
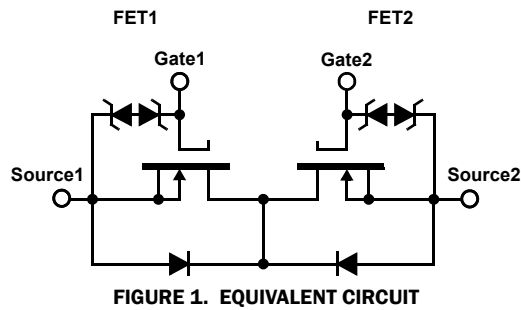

GWS9294

Ordering Information

PART NUMBER	PART MARKING	TEMP RANGE (°C)	PACKAGE (RoHS Compliant)
GWS9294	94	-55 to +150	4 Ld QFN

Pin Configuration

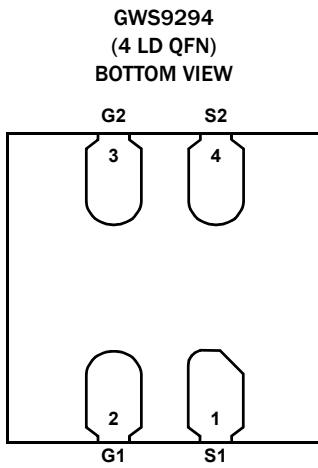

Pin Descriptions

PIN #	PIN NAME	DESCRIPTION
1	S1	Source of FET1
2	G1	Gate of FET1
3	G2	Gate of FET2
4	S2	Source of FET2

GWS9294

Absolute Maximum Ratings [\(Note 1\)](#)

Drain-to-Source Voltage (V_{DS})	20V
Gate-to-Source Voltage (V_{GS})	$\pm 12V$
Drain Current (I_D) (Note 2)	
$T_A = +25^\circ C$	10.1A (10s), 6.5A (Steady State)
$T_A = +70^\circ C$	8.1A (10s), 5.2A (Steady State)
Drain Current ($R_{thjFoot}$)	
$T_F = +25^\circ C$	15A (Steady State)
Pulsed Drain Current (I_{DM})	60A
ESD Rating	
Human Body Model	2.5kV

Thermal Information

Thermal Resistance (Typical)	θ_{JA} ($^\circ C/W$)	θ_{JF} ($^\circ C/W$)
$t \leq 10s$	35	
Steady State	85	16
Maximum Power Dissipation (P_D) (Note 2)		
$T_A = +25^\circ C$	3.6W (10s)	1.47W (Steady State)
$T_A = +70^\circ C$	2.29W (10s)	0.94W (Steady State)
Junction and Storage Temperature Range (T_J, T_{stg})	$-55^\circ C$ to $+150^\circ C$	
Pb-Free Reflow Profile	see TB493	

CAUTION: Do not operate at or near the maximum ratings listed for extended periods of time. Exposure to such conditions may adversely impact product reliability and result in failures not covered by warranty.

NOTES:

- $T_J = +25^\circ C$ unless otherwise noted.
- Surface mounted on FR4 board.

Electrical Characteristics $T_J = +25^\circ C$ unless otherwise noted

SYMBOL	PARAMETER	TEST CONDITIONS	MIN (Note 3)	TYP (Note 4)	MAX (Note 3)	UNIT
STATIC						
$V_{(BR)SSS}$	Drain-to-Source Breakdown Voltage	$V_{GS} = 0V, I_D = 250\mu A$	20			V
I_{SSS}	Zero Gate Voltage Drain Current	$V_{GS} = 0V, V_{DS} = 20V$			1	μA
I_{GSS}	Gate Body Leakage	$V_{DS} = 0V, V_{GS} = \pm 8V$			± 10	μA
$V_{GS(th)}$	Gate Threshold Voltage	$V_{DS} = V_{GS}, I_D = 1mA$	0.5	0.6	1.5	V
$r_{DS(ON)}$	Drain-to-Source On-State Resistance (Note 5) (per MOSFET)	$V_{GS} = 4.5V, I_D = 6.5A$	6	12	13	m Ω
		$V_{GS} = 4.0V, I_D = 6.5A$	7	13	14	m Ω
		$V_{GS} = 3.1V, I_D = 6.0A$	8	14	18	m Ω
		$V_{GS} = 2.5V, I_D = 5.5A$	9	16	20	m Ω
$r_{SS(ON)}$	Source-to-Source On-State Resistance (Note 5) (both MOSFETs in series)	$V_{GS} = 4.5V, I_D = 6.5A$	12	24	26	m Ω
		$V_{GS} = 4.0V, I_D = 6.5A$	13	25	28	m Ω
		$V_{GS} = 3.1V, I_D = 6.0A$	16	28	35	m Ω
		$V_{GS} = 2.5V, I_D = 5.5A$	17	32	40	m Ω
V_{SD}	Source-to-Drain Diode Voltage	$V_{GS} = 0, I_S = 6.5A$	0.5	0.8	1	V
DYNAMIC						
Q_g	Total Gate Charge	$V_{DS} = 10V, I_D = 5.0A, V_{GS} = 4.0V$		11		nC
C_{iss}	Input Capacitance	$V_{DS} = 10V, V_{GS} = 0V, f = 1MHz$		900		pF
C_{oss}	Output Capacitance			300		pF
C_{rss}	Reverse Transfer Capacitance			150		pF

NOTES:

- Compliance to datasheet limits is assured by one or more methods: production test, characterization and/or design.
- Typical values are for $T_A = +25^\circ C$.
- Good Kelvin measurement required.

Test Circuit Examples for Measuring FET1 Key Parameters

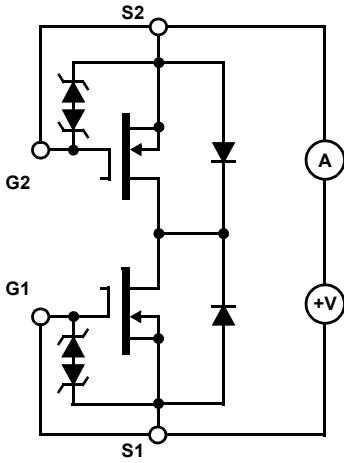

FIGURE 3. I_{SSS} TEST CIRCUIT

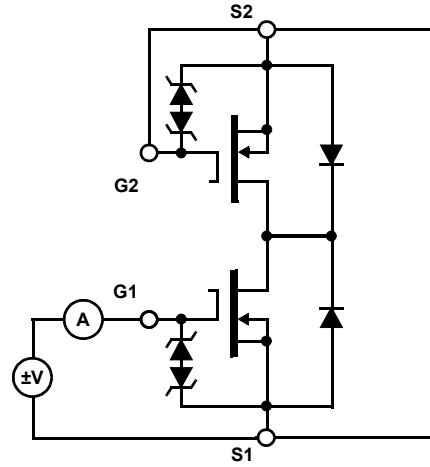

FIGURE 4. I_{GSS} TEST CIRCUIT

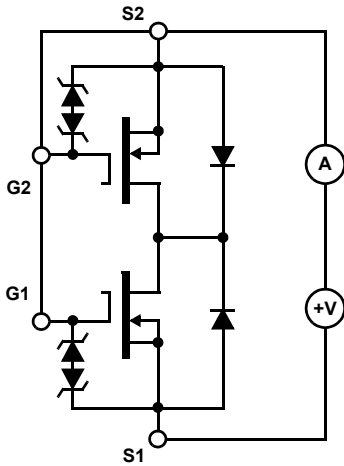

FIGURE 5. $V_{GS(th)}$ TEST CIRCUIT

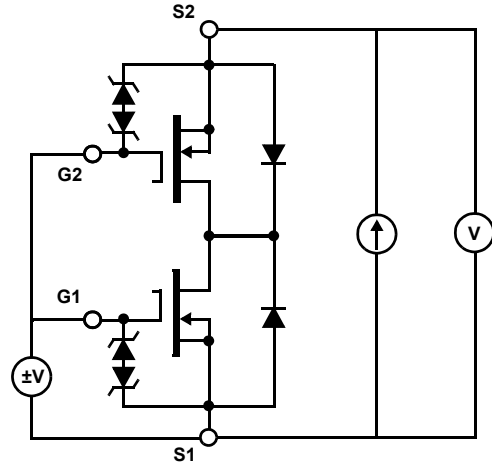

FIGURE 6. $r_{SS(ON)}$ TEST CIRCUIT

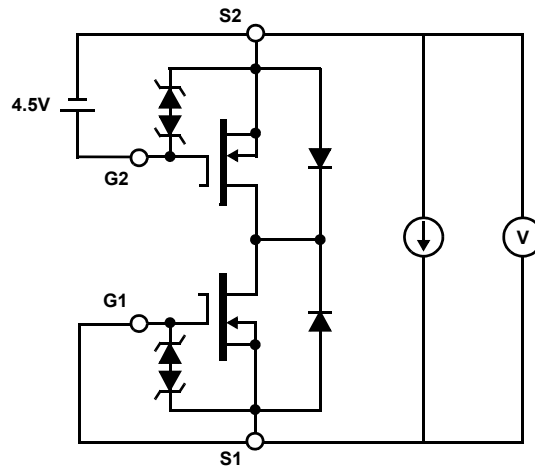

FIGURE 7. V_{FS-S} TEST CIRCUIT

Typical Performance Curves

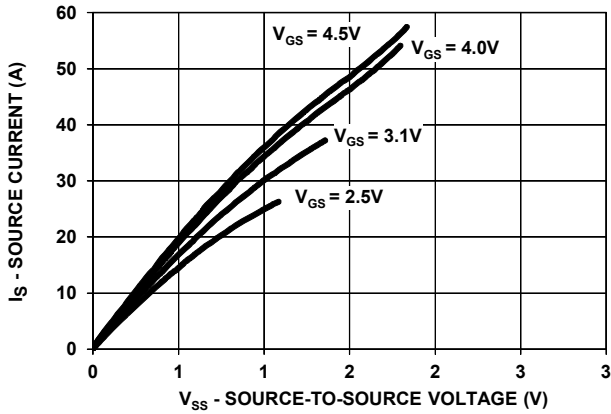

FIGURE 8. OUTPUT CHARACTERISTICS

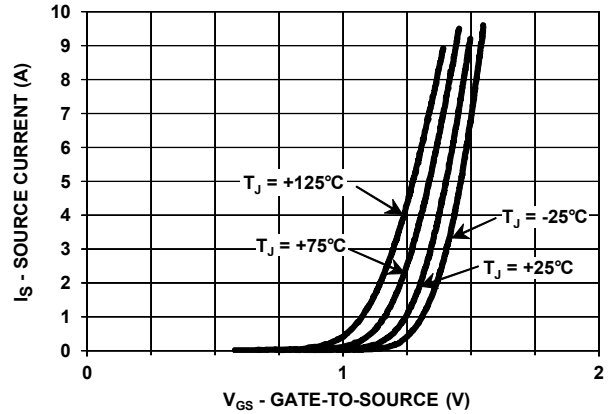

FIGURE 9. TRANSFER CHARACTERISTICS

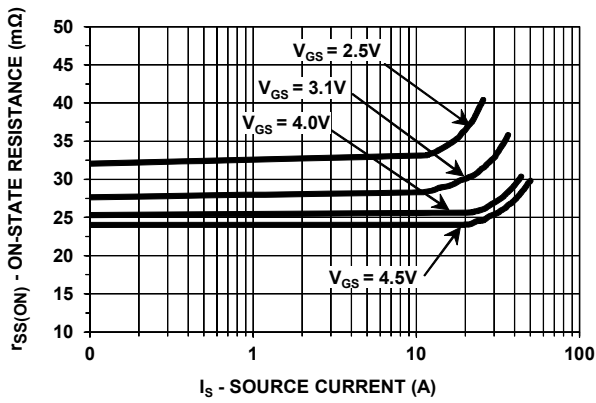

FIGURE 10. SOURCE-TO-SOURCE ON-STATE RESISTANCE vs SOURCE CURRENT

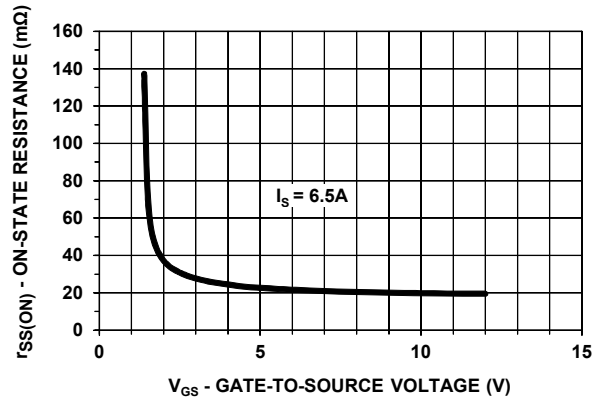

FIGURE 11. SOURCE-TO-SOURCE ON-STATE RESISTANCE vs GATE-TO-SOURCE VOLTAGE

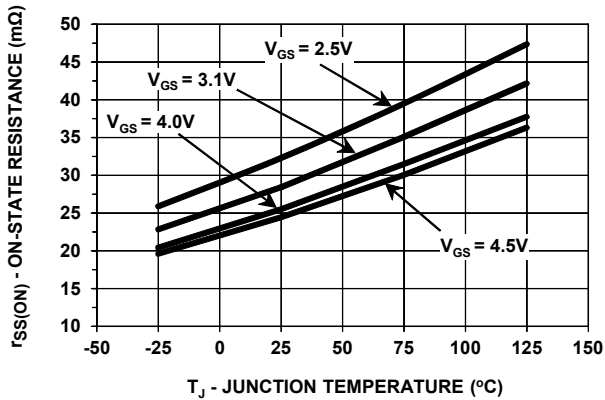

FIGURE 12. SOURCE-TO-SOURCE ON-STATE RESISTANCE vs JUNCTION TEMPERATURE

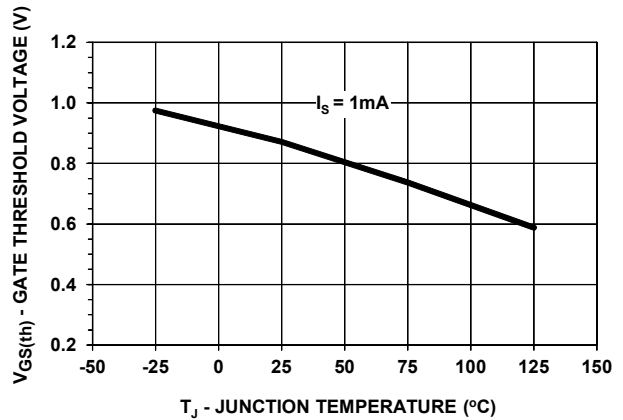

FIGURE 13. GATE THRESHOLD VOLTAGE vs JUNCTION TEMPERATURE

Typical Performance Curves (Continued)

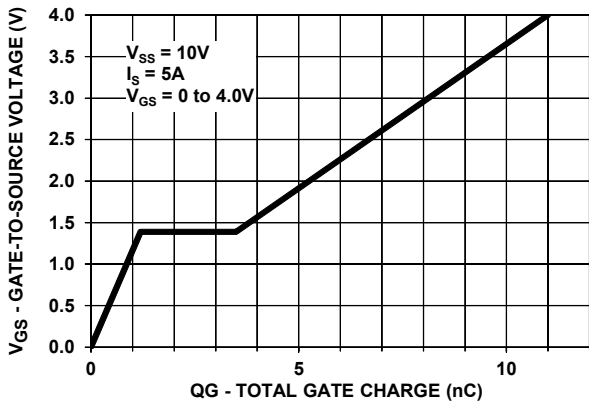

FIGURE 14. GATE CHARGE

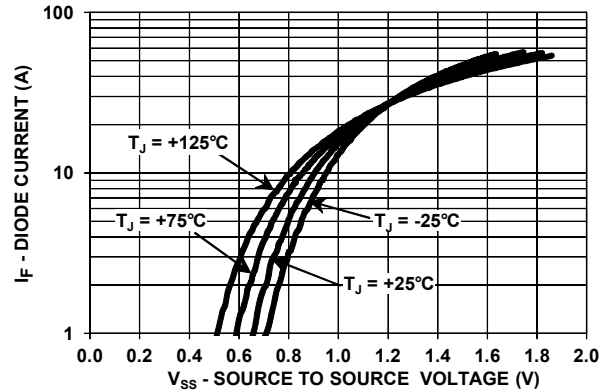

FIGURE 15. SOURCE-TO-SOURCE DIODE FORWARD VOLTAGE

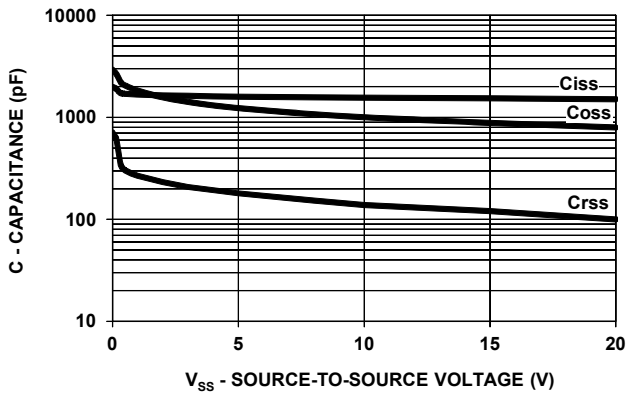

FIGURE 16. CAPACITANCE

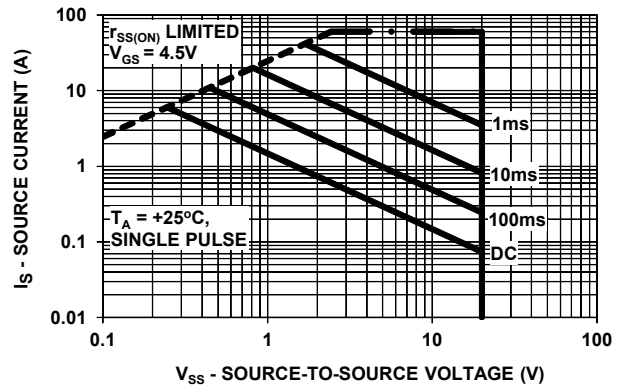

FIGURE 17. MAXIMUM RATED FORWARD BIASED SAFE OPERATING AREA

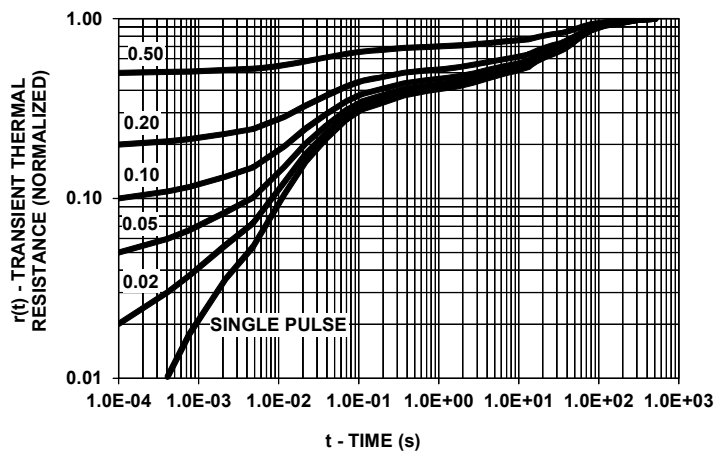

FIGURE 18. TRANSIENT THERMAL RESPONSE, JUNCTION-TO-AMBIENT

Revision History

The revision history provided is for informational purposes only and is believed to be accurate, but not warranted. Please go to the web to make sure that you have the latest revision.

DATE	REVISION	CHANGE
December 22, 2015	FN8786.1	Added "Note 1. $T_J = +25^\circ\text{C}$ unless otherwise noted." to Abs Max on page 3.
October 30, 2015	FN8786.0	Initial release.

About Intersil

Intersil Corporation is a leading provider of innovative power management and precision analog solutions. The company's products address some of the largest markets within the industrial and infrastructure, mobile computing and high-end consumer markets.

For the most updated datasheet, application notes, related documentation and related parts, please see the respective product information page found at www.intersil.com.

You may report errors or suggestions for improving this datasheet by visiting www.intersil.com/ask.

Reliability reports are also available from our website at www.intersil.com/support.

For additional products, see www.intersil.com/en/products.html

Intersil products are manufactured, assembled and tested utilizing ISO9001 quality systems as noted in the quality certifications found at www.intersil.com/en/support/qualandreliability.html

Intersil products are sold by description only. Intersil Corporation reserves the right to make changes in circuit design, software and/or specifications at any time without notice. Accordingly, the reader is cautioned to verify that data sheets are current before placing orders. Information furnished by Intersil is believed to be accurate and reliable. However, no responsibility is assumed by Intersil or its subsidiaries for its use; nor for any infringements of patents or other rights of third parties which may result from its use. No license is granted by implication or otherwise under any patent or patent rights of Intersil or its subsidiaries.

For information regarding Intersil Corporation and its products, see www.intersil.com

Package Outline and Dimensions

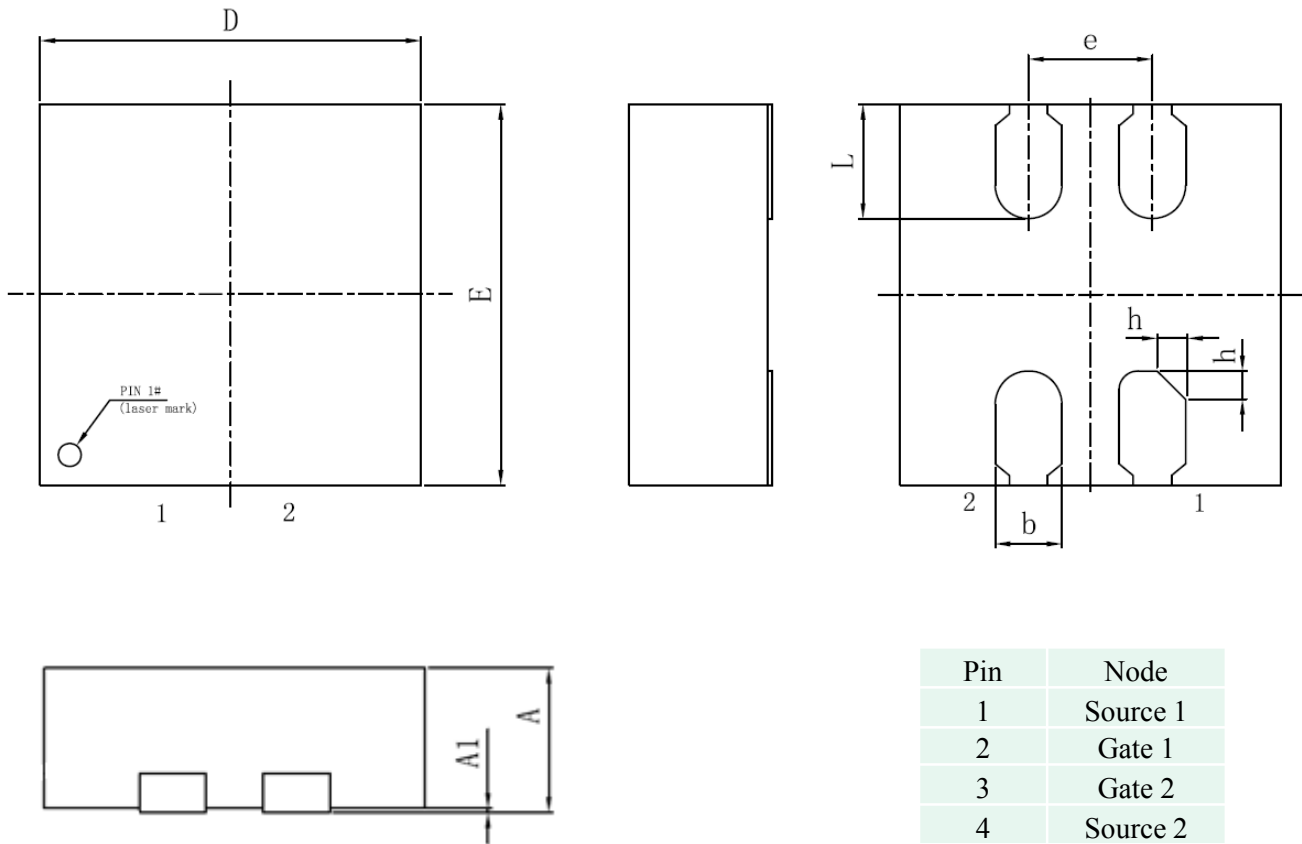

Symbol	Min	Nom	Max
A	0.70		1.00
A1		0.02	0.05
b	0.275		0.400
D	2.00 BSC		
E	2.00 BSC		
e	0.65 BSC		
L	0.55	0.60	0.65
h	0.10	0.15	0.20

All dimensions in mm

Mounting Pad Layout and Dimensions

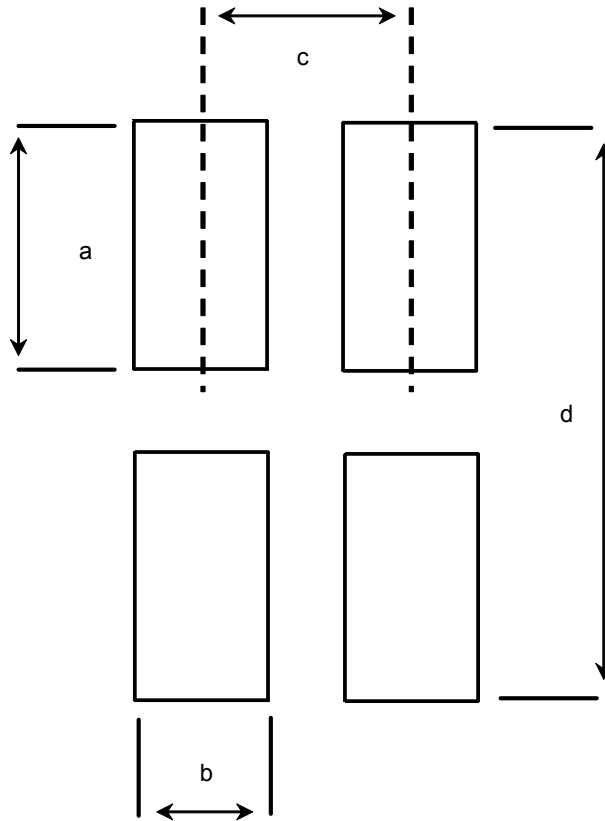

Symbol	Min	Nom	Max
a	0.788	0.838	0.888
b	0.358	0.381	0.404
c	0.65 BSC		
d	2.22	2.365	2.50

All dimensions in mm