



Chipsmall Limited consists of a professional team with an average of over 10 year of expertise in the distribution of electronic components. Based in Hongkong, we have already established firm and mutual-benefit business relationships with customers from,Europe,America and south Asia,supplying obsolete and hard-to-find components to meet their specific needs.

With the principle of “Quality Parts,Customers Priority,Honest Operation,and Considerate Service”,our business mainly focus on the distribution of electronic components. Line cards we deal with include Microchip,ALPS,ROHM,Xilinx,Pulse,ON,Everlight and Freescale. Main products comprise IC,Modules,Potentiometer,IC Socket,Relay,Connector.Our parts cover such applications as commercial,industrial, and automotives areas.

We are looking forward to setting up business relationship with you and hope to provide you with the best service and solution. Let us make a better world for our industry!



Contact us

Tel: +86-755-8981 8866 Fax: +86-755-8427 6832

Email & Skype: info@chipsmall.com Web: www.chipsmall.com

Address: A1208, Overseas Decoration Building, #122 Zhenhua RD., Futian, Shenzhen, China





Features

- No backlash
- Compact - requires minimal panel space (22.2 mm diameter requirement)
- For use with precision potentiometers or other rotating devices, up to 15 turns
- Designed for metal shaft
- High Force "Click Brake"
- Black on polished chrome background
- RoHS compliant*

H-23 Turns-Counting Dial

Mechanical and Physical Characteristics

Number of Turns	0 to 15
Dial Divisions.....	50 per turn
Readability - Over 10 Turns	2 parts in 1000
Torque With Brake Engaged	6.95 oz-in. (500 g-cm) minimum
Markings	Black on polished chrome background
Locking Brake	Yes
Weight	15 grams (0.53 oz.)
Set Screw.....	UNC N2-56, one included
Set Screw Tightening Torque.....	16.94 N-cm (1.5 lbs.-in.) minimum
Hex Key Size.....	0.05 in. hex

Shaft and Bushing Requirements

Shaft Diameter Requirements.....	Refer to chart below
Shaft Extension Beyond Panel	18.1 mm (0.712 in.) minimum
	22.2 mm (0.875 in.) maximum
Bushing Extension Beyond Panel.....	9.53 mm (0.375 in.) maximum

H-23 MOUNTING INSTRUCTIONS

1. Insert potentiometer in panel.
2. Install anti-rotation device using hardware supplied with potentiometer.
3. Turn potentiometer shaft counterclockwise to minimum resistance or voltage ratio.
4. Set the dial to "0.0" and brake on.
5. Insert the dial on the potentiometer shaft lightly against the panel.
6. Tighten set screw to potentiometer shaft.

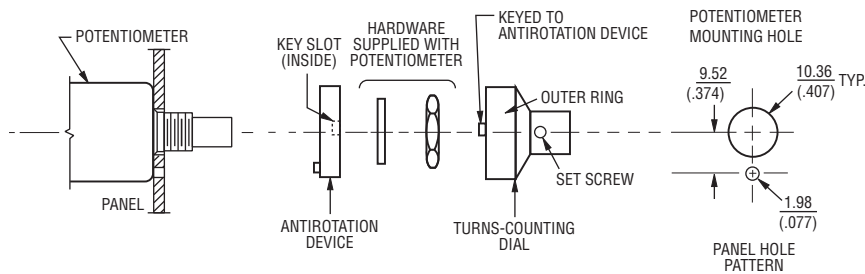

Dimensional Drawings

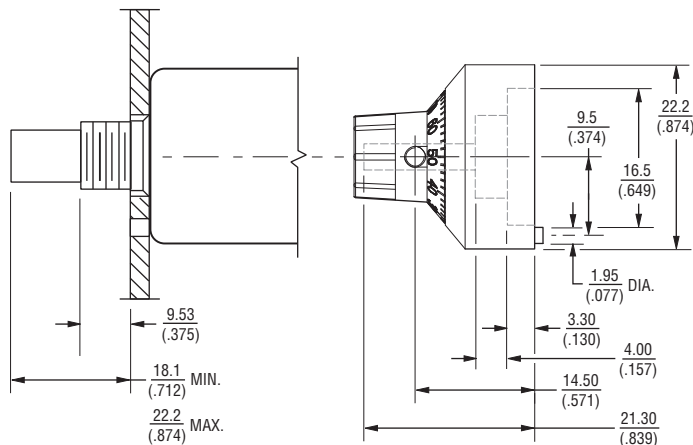

How To Order

Part Number	Accepts Shaft Diameter	Finish
H-23-6A	6.35 (.250)	Polished chrome
H-23-6M	6.0 (.236)	Polished chrome
H-23-3A	3.17 (.124)	Polished chrome

DIMENSIONS: $\frac{\text{MM}}{\text{(INCHES)}}$

REV. 10/12

*RoHS Directive 2002/95/EC Jan. 27, 2003 including annex and RoHS Recast 2011/65/EU June 8, 2011.
Specifications are subject to change without notice.
Customers should verify actual device performance in their specific applications.