



Chipsmall Limited consists of a professional team with an average of over 10 year of expertise in the distribution of electronic components. Based in Hongkong, we have already established firm and mutual-benefit business relationships with customers from,Europe,America and south Asia,supplying obsolete and hard-to-find components to meet their specific needs.

With the principle of “Quality Parts,Customers Priority,Honest Operation,and Considerate Service”,our business mainly focus on the distribution of electronic components. Line cards we deal with include Microchip,ALPS,ROHM,Xilinx,Pulse,ON,Everlight and Freescale. Main products comprise IC,Modules,Potentiometer,IC Socket,Relay,Connector.Our parts cover such applications as commercial,industrial, and automotives areas.

We are looking forward to setting up business relationship with you and hope to provide you with the best service and solution. Let us make a better world for our industry!



Contact us

Tel: +86-755-8981 8866 Fax: +86-755-8427 6832

Email & Skype: info@chipsmall.com Web: www.chipsmall.com

Address: A1208, Overseas Decoration Building, #122 Zhenhua RD., Futian, Shenzhen, China



QT-Brightek Opto-Coupler Series

6-PIN DIP PHOTOCOUPLER SCHMITT TRIGGER

Part No.: H11L1_H11L2_H11L3



Table of Contents:

Introduction3

Absolute Maximum Rating6

Electrical Characteristic: (T=25 °C)7

Isolation Characteristics7

Characteristic Curves.....9

Test Circuit for Response Time.....10

Solder Profile & Footprint13

Device Marking14

Tape and Reel Packing Specifications.....15

Ordering Information16

Revision History17

Disclaimer17

Product: H11L1 H11L2 H11L3	Date: February 09, 2018	Page 2 of 18
	Version# 1.4	

Introduction

Feature:

- High data rate, 1MHz typ. (NRZ)
- Microprocessor compatible drive
- Free from latch up and oscillation throughout voltage and temperature ranges
- Wide supply voltage capability, compatible with all popular logic systems
- High Isolation voltage between input and output (Viso = 5000V rms)
- Logic compatible output sinks 16mA at 0.4V max.
- Guaranteed on/off threshold hysteresis
- Available packaged in Tube or Tape and reel

Certification & Compliance:

- Pb free and RoHS Compliant
- UL recognized (File #E338132)



Schematic:

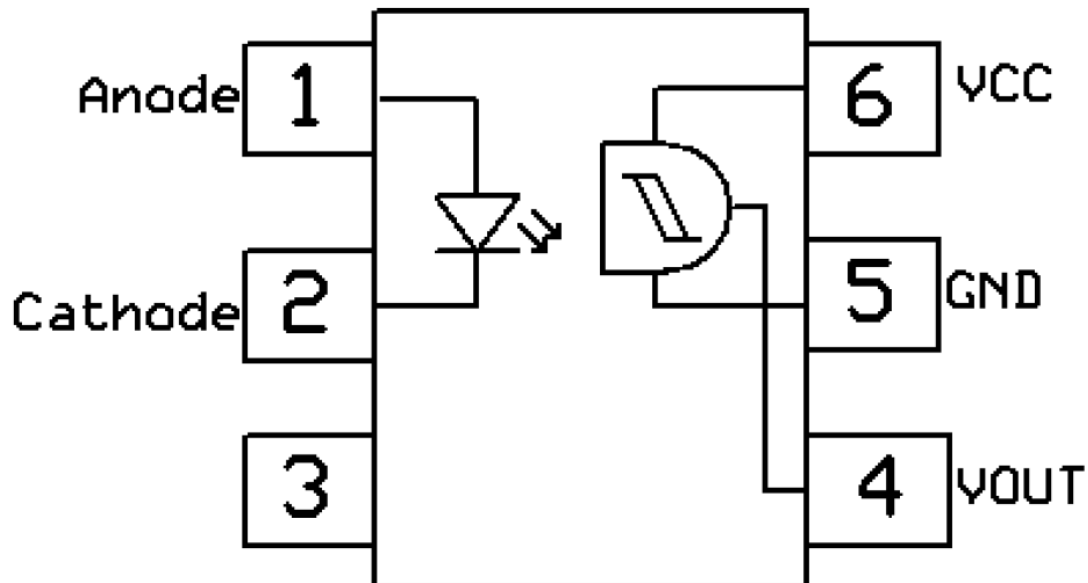

Dimension: (Dot location indicates pin 1)

6-Pin Dip (standard):

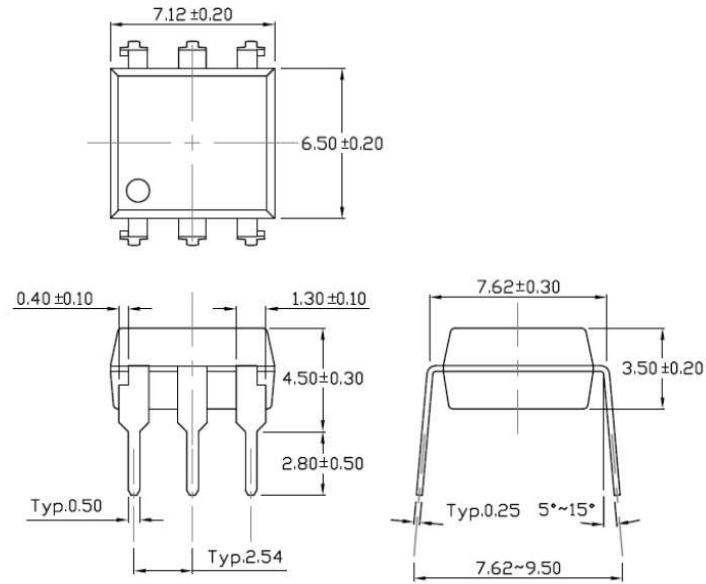

Wide lead bend (Option W):

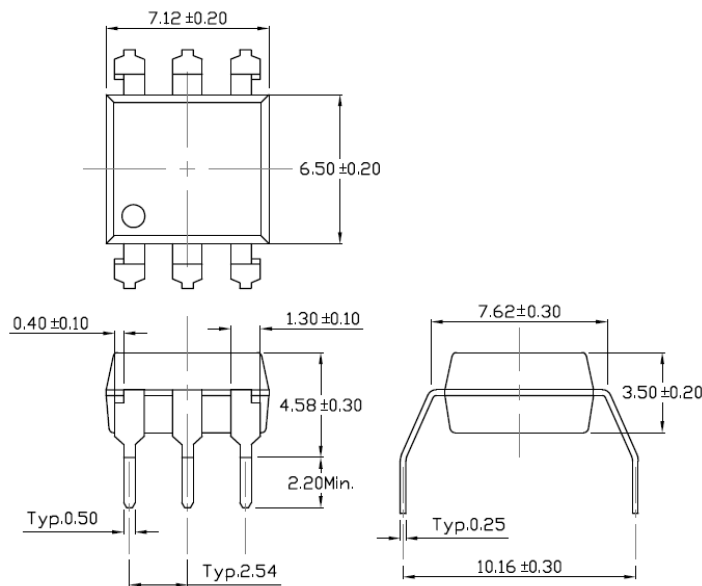

All Dimensions are in mm
Tolerance = +/- 0.1mm

Product: H11L1 H11L2 H11L3	Date: February 09, 2018	Page 4 of 18
	Version# 1.4	

SMD lead bend (Option S):

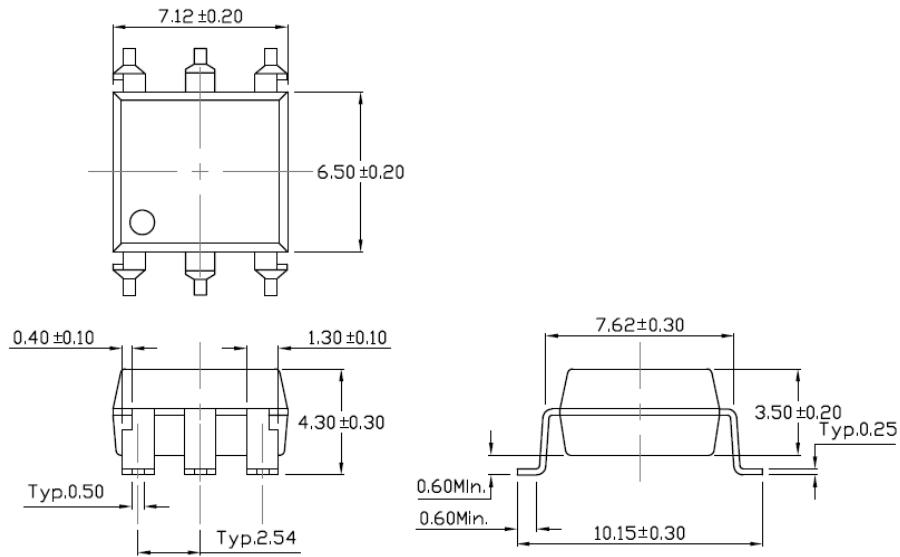

SMD (Low Profile) bend (Option SL):

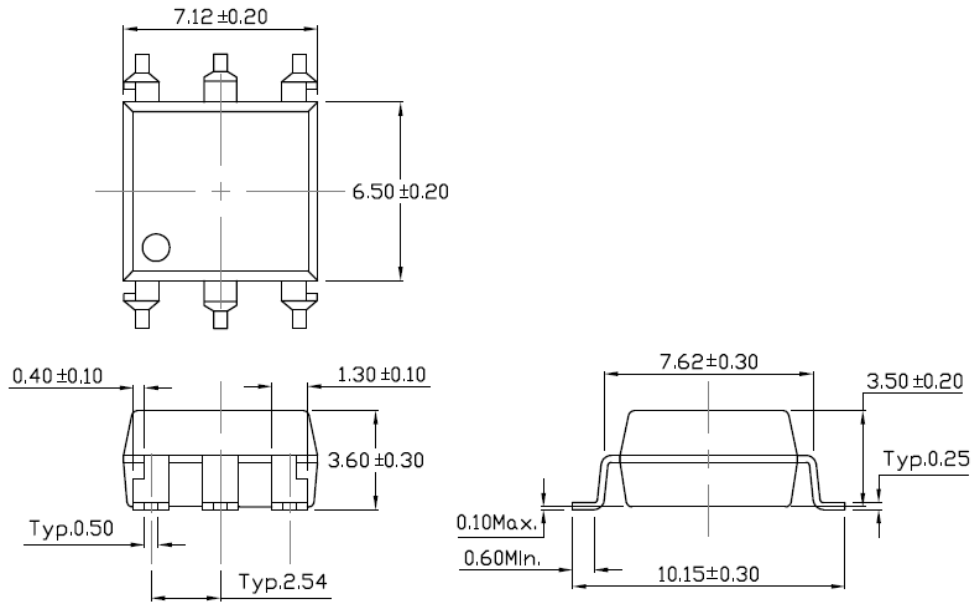

All Dimensions are in mm
Tolerance = +/- 0.1mm

Absolute Maximum Rating

Symbol	Parameter	Rating	Units
		H11L1 H11L2 H11L3	
T _{STG}	Storage Temperature	-55 ~ +150	°C
T _{OPR}	Operating Temperature	-40 ~ +100	°C
T _{SOL}	Lead Solder Temperature	260	°C
V _{ISO}	Isolation voltage	5000	VRMS
EMITTER			
I _F	Continuous Forward Current	60	mA
I _{PF}	Peak Forward Current (300us pulse, ≤1 μs P.W)	1	A
V _R	Reverse Voltage	6	V
P _D	Power Dissipation	100	mW
DETECTOR			
V _O	Output Voltage	0 to 16	V
V _{CC}	Supply Voltage	3 to 16	V
I _O	Output Current	50	mA
P _D	Power Dissipation	150	mW

**Electrical Characteristic: (T=25 °C)
Emitter**

Symbol	Characteristic	Device	Test Condition	Range			Unit
				Min	Typ	Max	
V _F	Forward voltage	H11L1 H11L2 H11L3	I _F = 10mA	-	1.2	1.4	V
I _R	Reverse current	H11L1 H11L2 H11L3	V _R = 6V	-	-	5	μA
C _J	Capacitance	H11L1 H11L2 H11L3	V = 0, f = 1KHz	-	45	-	pF

Detector

Symbol	Characteristic	Device	Test Condition	Range			Unit
				Min	Typ	Max	
V _{CC}	Operation Voltage Range	H11L1 H11L2 H11L3		3	-	15	V
I _{CCH}	Logic High Supply Current	H11L1 H11L2 H11L3	I _F = 0mA, V _{CC} = 5v	-	1.5	5	mA
I _{OH}	Logic High Output Current	H11L1 H11L2 H11L3	I _F = 0mA, V _{CC} = V _O = 15V	-	-	100	μA

Isolation Characteristics

R _{ISO}	Isolation Resistance	H11L1 H11L2 H11L3	V _{LO} = 500VCD	10 ¹¹	-	-	Ω
C _{IO}	Isolation Capacitance		f=1 MHz	-	0.25	-	pF

Symbol	Characteristic	Device	Test Condition	Range			Unit
				Min	Typ	Max	
DC Transfer Characteristic							
I_{CCL}	Logic Low Supply Current	H11L1 H11L2 H11L3	$I_F = 10\text{mA}, V_{CC} = 5\text{V}$	-	1.5	5	mA
V_{OL}	Logic Low Output Voltage	H11L1 H11L2 H11L3	$V_{CC} = 5\text{V}, I_F = I_{FON(max)}, R_L = 270\Omega$	-	-	0.4	V
I_{FON}	Turn on Threshold Current ¹	H11L1	$V_{CC} = 5\text{V}, R_L = 270\Omega$	-	-	1.6	mA
		H11L2		-	-	10	mA
		H11L3		-	-	5	mA
I_{FOFF}	Turn off Threshold Current	H11L1 H11L2 H11L3	$V_{CC} = 5\text{V}, R_L = 270\Omega$	0.3	1	-	mA
I_{fon}/I_{foo}	Hysteresis Ratio	H11L1 H11L2 H11L3	$V_{CC} = 5\text{V}, R_L = 270\Omega$	0.5	-	0.9	
AC Transfer Characteristic							
T_{on}	Turn on Time	H11L1 H11L2 H11L3	$V_{CC} = 5\text{V}, I_F = I_{FON}, R_L = 270\Omega$	-	-	3.8	μS
T_r	Rise Time	H11L1 H11L2 H11L3	$V_{CC} = 5\text{V}, I_F = I_{FON}, R_L = 270\Omega$	-	0.1	-	μS
T_{off}	Turn off Time	H11L1 H11L2 H11L3	$V_{CC} = 5\text{V}, I_F = I_{FON}, R_L = 270\Omega$	-	-	3.8	μS
T_f	Fall Time	H11L1 H11L2 H11L3	$V_{CC} = 5\text{V}, I_F = I_{FON}, R_L = 270\Omega$	-	0.1	-	μS
	Data Rate	H11L1 H11L2 H11L3		-	1	-	MHz

¹. Max. $I_{F(on)}$ is the maximum current required to trigger the output. For examples, a 1.6mA maximum trigger current would require the LED to be driven at a current greater than 1.6mA to guarantee the device will turn on. A 10% guard band is recommended to account for degradation of the LED over its lifetime. The maximum allowable LED drive current is 60mA

Characteristic Curves

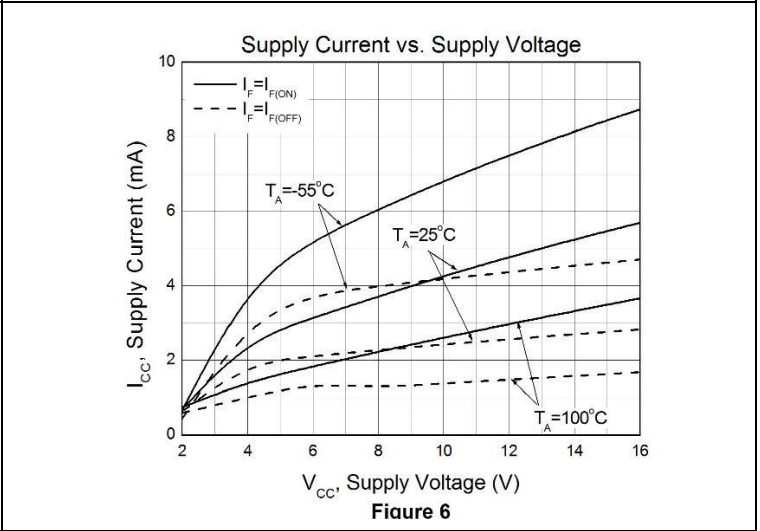
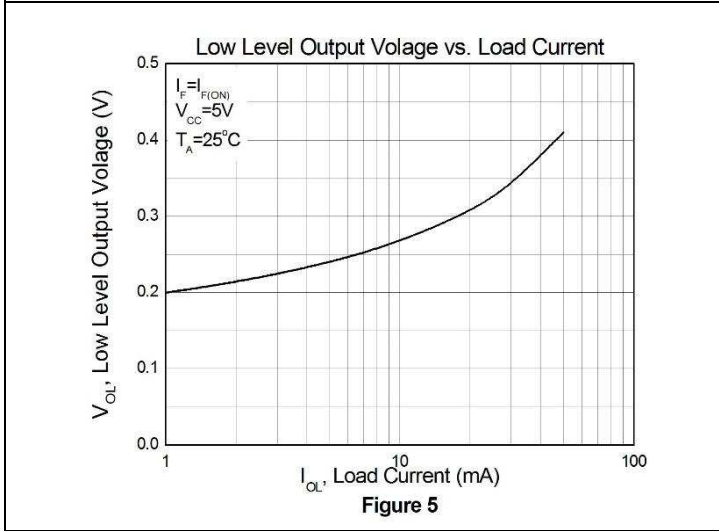
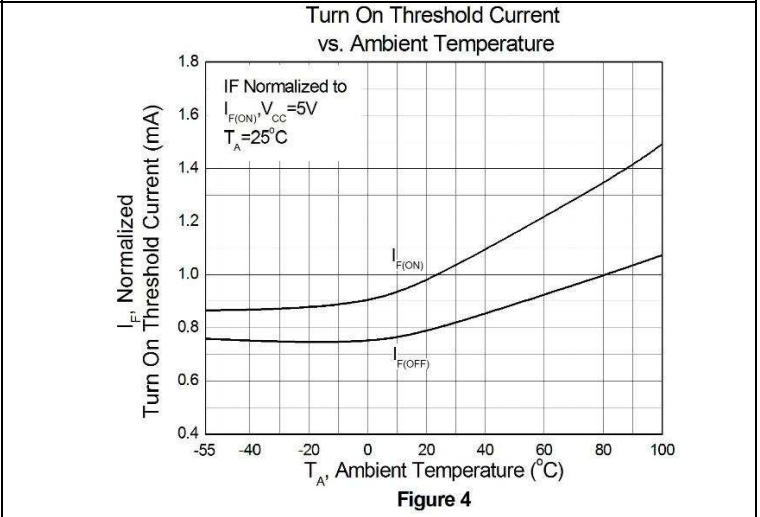
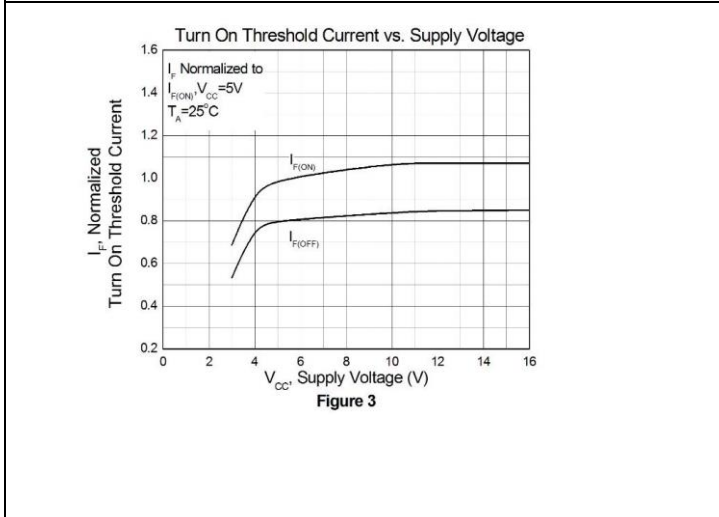
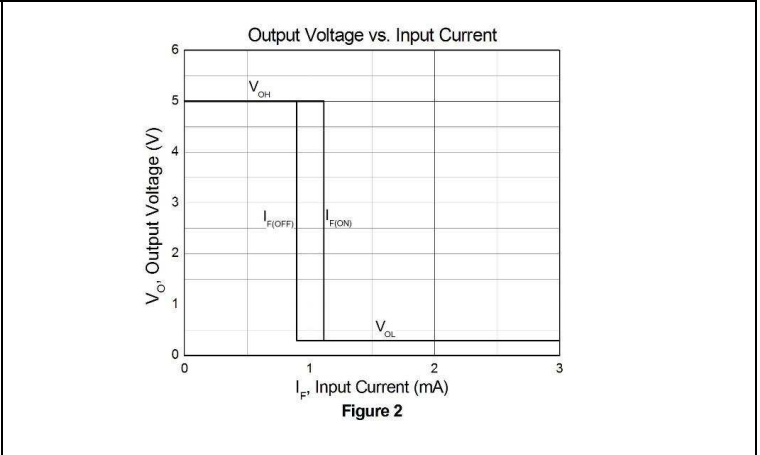
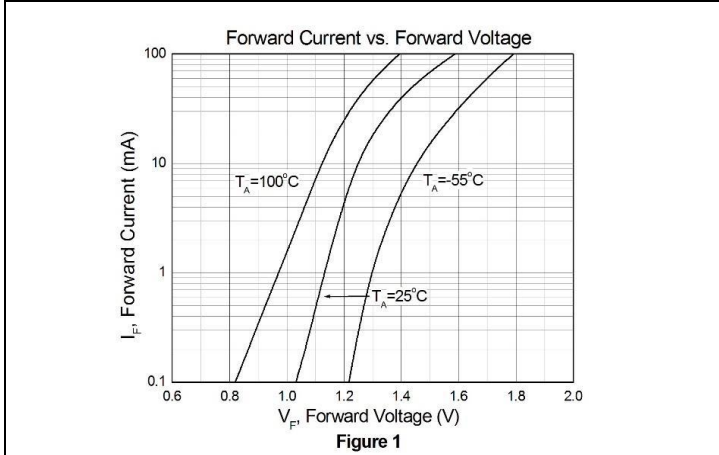

Test Circuit for Response Time

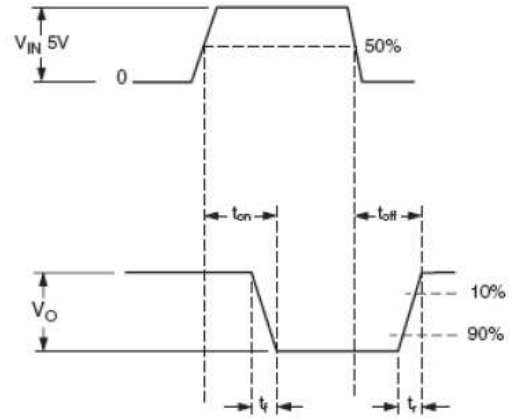
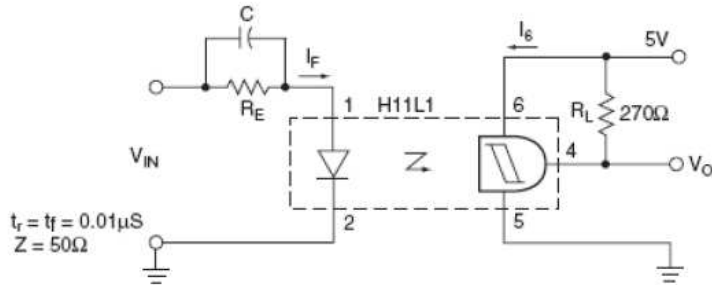

Solder Profile & Footprint

Wave soldering

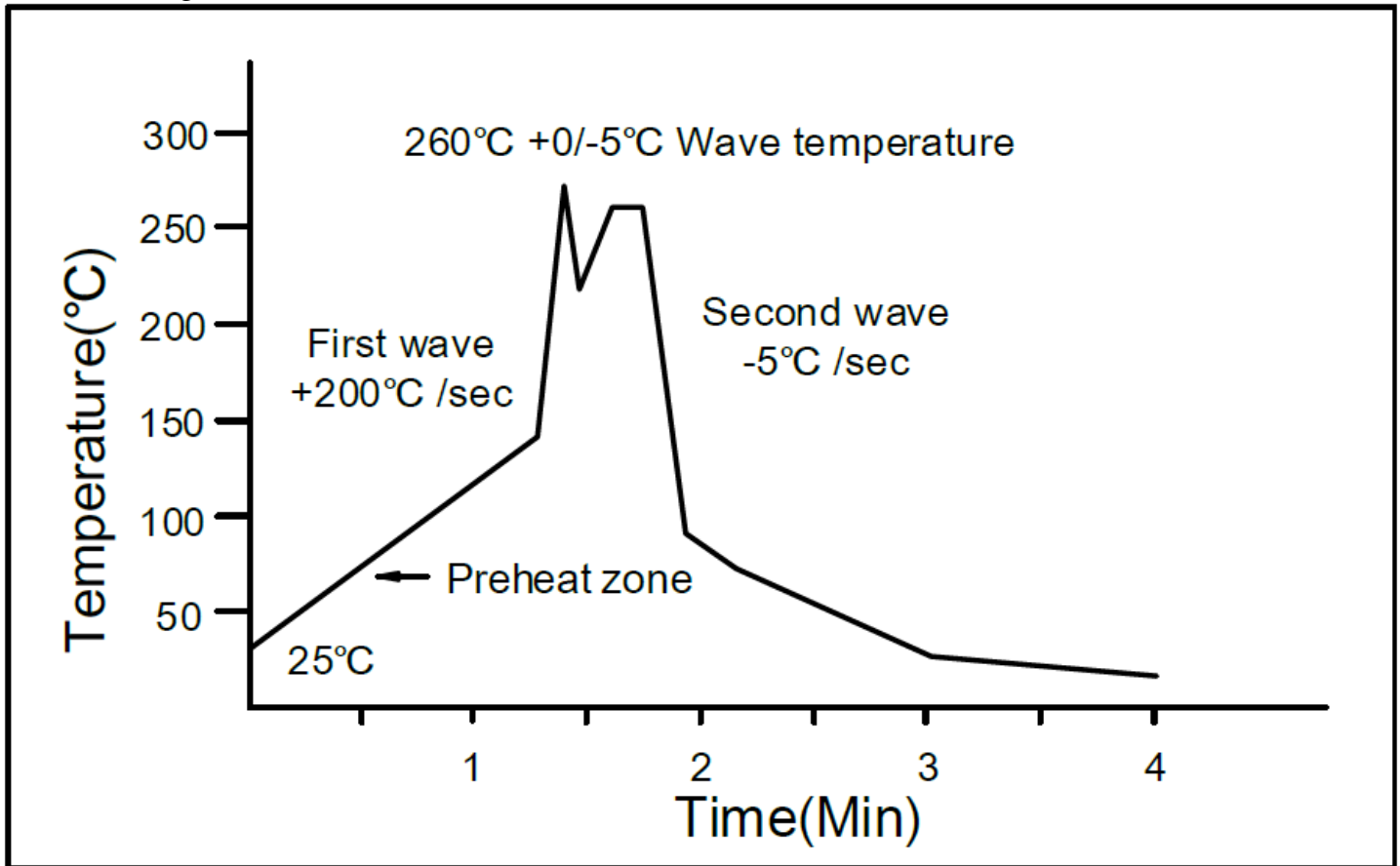

Temperature: 260 +0/-5 °C

Time: 10 Sec

Preheat temperature: 25 to 140 °C

Preheat time: 30 to 80 sec.

Reflow soldering

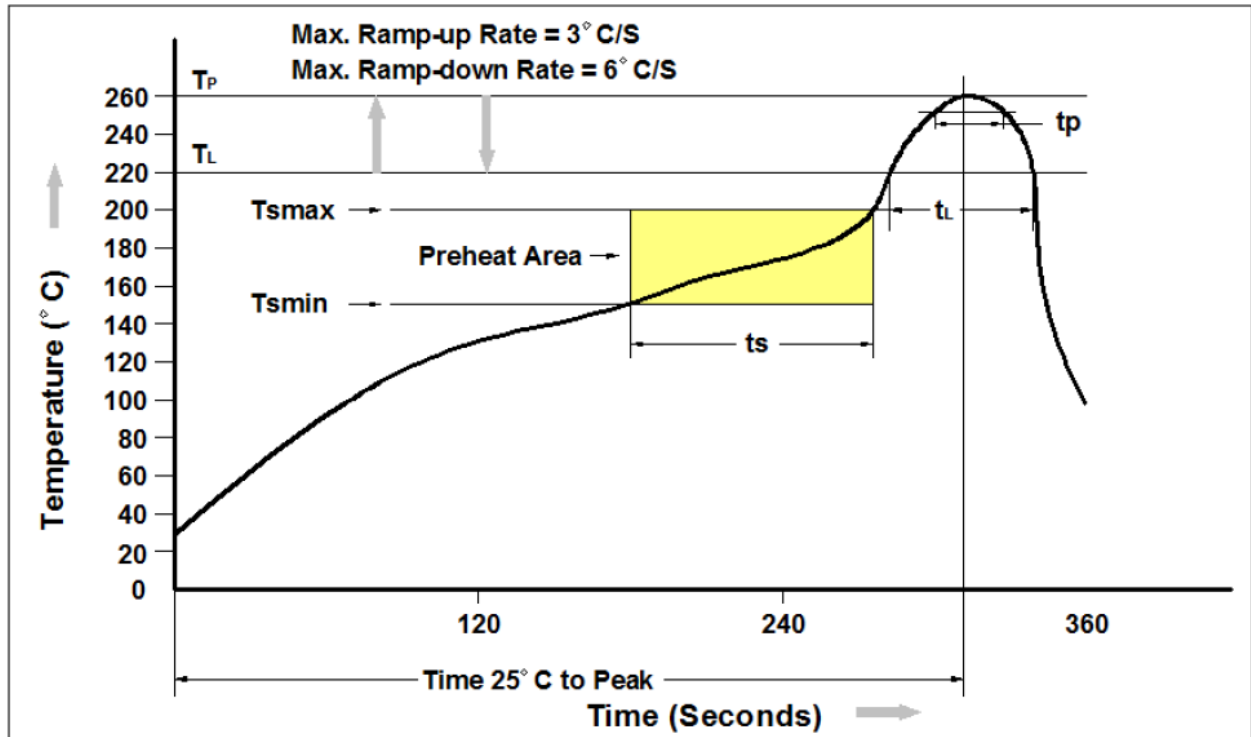

Profile Feature	Pb-Free Assembly Profile
Temperature Min. (T _{smin})	150 °C
Temperature Max. (T _{smax})	200 °C
Time (t _s) from (T _{smin} to T _{smax})	60-120 seconds
Ramp-up Rate (t _L to t _P)	3°C/second max.
Liquidous Temperature (T _L)	217 °C
Time (t _L) Maintained Above (T _L)	60 – 150 seconds
Peak Body Package Temperature	260 °C +0 °C / -5 °C
Time (t _P) within 5 °C of 260 °C	30 seconds
Ramp-down Rate (T _P to T _L)	6°C/second max
Time 25 °C to Peak Temperature	8 minutes max.

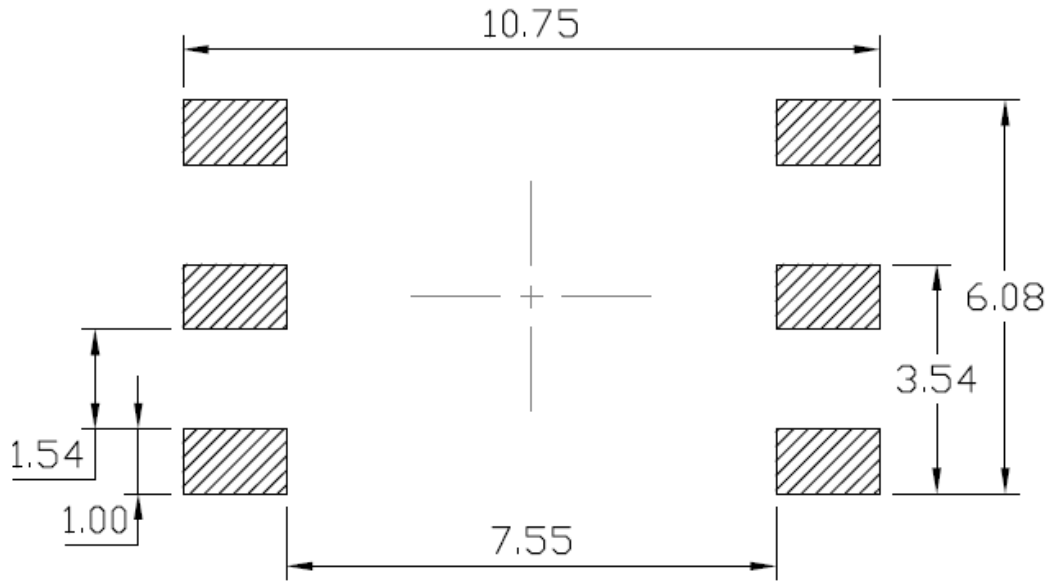
Solder Profile & Footprint

Recommended Solder Footprint for SMD Leadform

Units: mm

tolerance: +/- 0.1mm

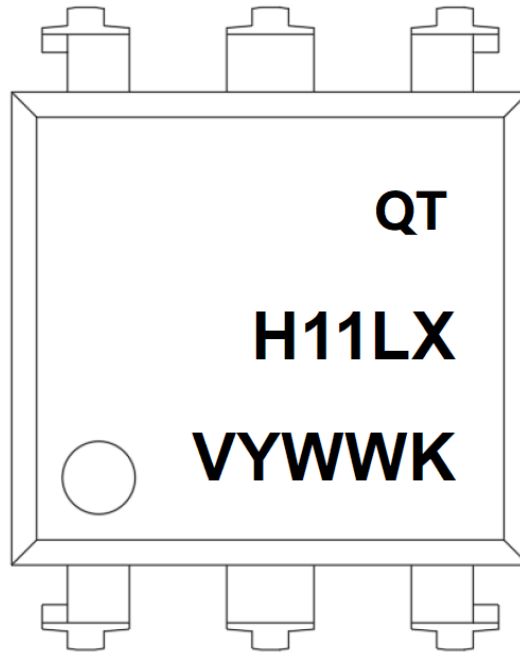
Device Marking

QT = QT-Brightek Corporation
H11LX = part number (X=1, 2, or 3)
Y = Year
WW = Week
V = VDE Option
K = Manufacturing code

Product: H11L1 H11L2 H11L3	Date: February 09, 2018	Page 14 of 18
	Version# 1.4	

Tape and Reel Packing Specifications

Option S(T1) & SL(T1)

Input Direction
→

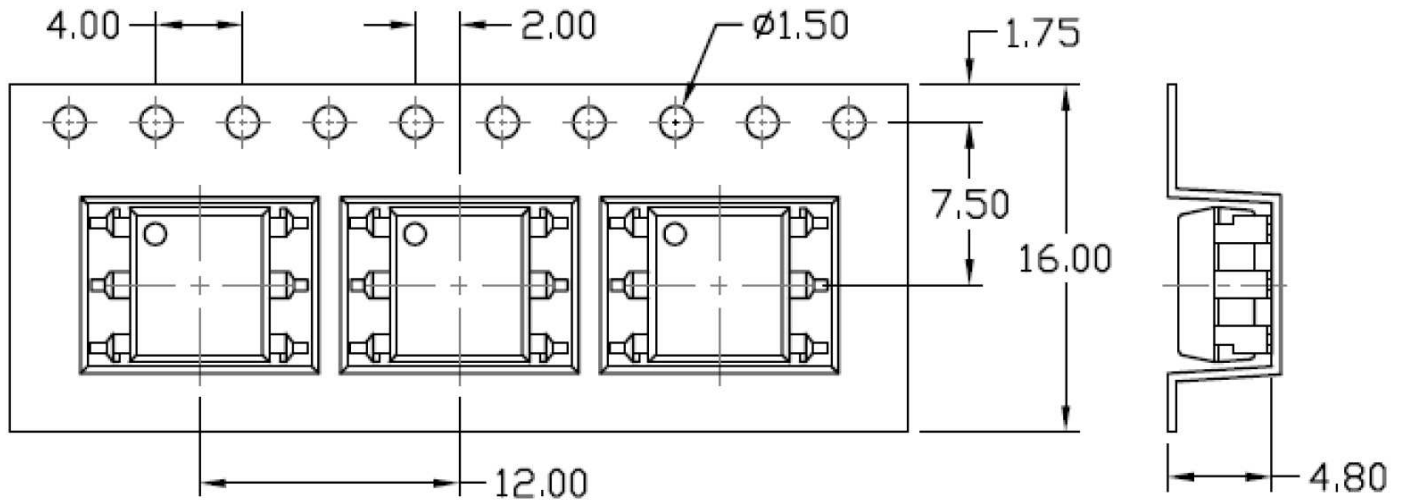

Option S(T2) & SL(T2)

Input Direction
→

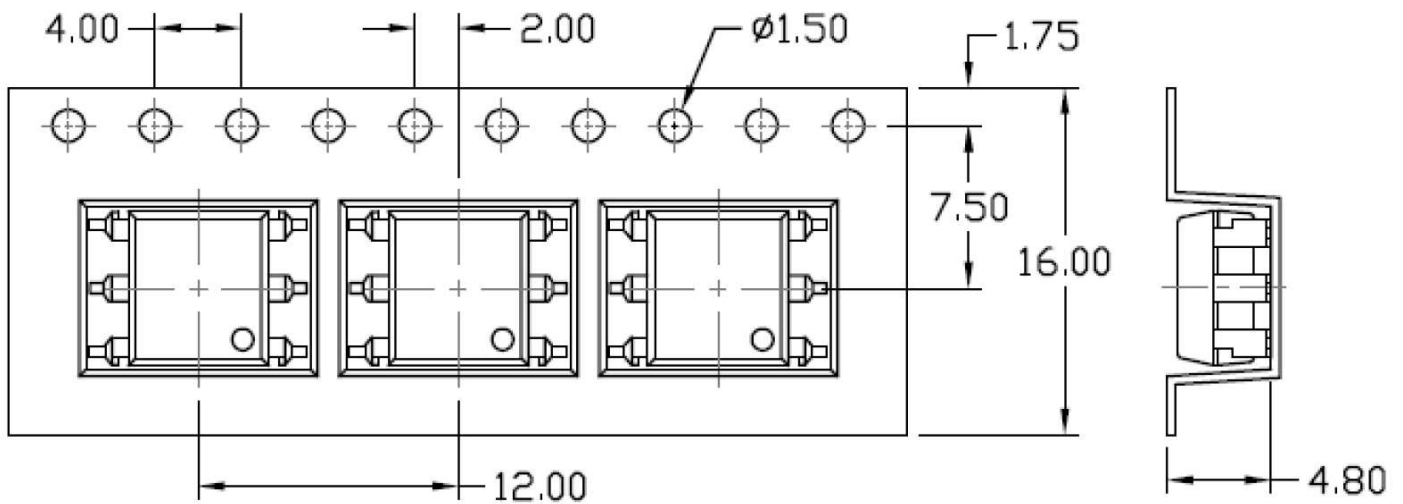



Ordering Information

H11LX(V)(Y)(Z)

X= Part number (X=1, 2, or 3)

V = VDE option (V or None)

Y = Lead form option (S, SL or none)

Z=Tape and reel option (T1 or T2 or none)

Option	Description	Quantity
None	Standard 6-Pin DIP	50 Units/Tube
M	Gullwing	50 Units/Tube
S(T1)	Surface Mount Lead Forming – with Option 1 Taping	1000 pcs/ reel
S(T2)	Surface Mount Lead Forming – with Option 2 Taping	1000 pcs/ reel
SL(T1)	SMD (Low Profile) Lead Forming – with Option 1 Taping	1000 pcs/ reel
SL(T2)	SMD (Low Profile) Lead Forming – with Option 2 Taping	1000 pcs/ reel



Revision History

Description:	Revision #	Revision Date
Initial release of H11L1 H11L2 H11L3	1.0	4/22/2010
Information updates	1.1	04/07/2011
Amend packing information	1.2	12/16/2011
Update to new format/update packing spec	1.3	07/17/2012
Amend the spec and packing information	1.4	02/09/2018

Disclaimer

QT-BRIGHTTEK reserves the right to make changes without further notice to any products herein to improve reliability, function or design. QT-BRIGHTTEK does not assume any liability arising out of the application or use of any product or circuit described herein; neither does it convey any license under its patent rights, nor the rights of others.

Life Support Policy

QT-BRIGHTTEK's products are not authorized for use as critical components in life support devices or systems without the express written approval of QT-BRIGHTTEK. As used herein:

1. Life support devices or systems are devices or systems which, (a) are intended for surgical implant into the body, or (b) support or sustain life, and (c) whose failure to perform when properly used in accordance with instructions for use provided in the labeling, can be reasonably expected to result in a significant injury of the user.
2. A critical component in any component of a life support device or system whose failure to perform can be reasonably expected to cause the failure of the life support device or system, or to affect its safety or effectiveness.

Product: H11L1 H11L2 H11L3	Date: February 09, 2018	Page 17 of 18
	Version# 1.4	



H11L1 H11L2 H11L3

6-PIN DIP PHOTOCOUPLER
SCHMITT TRIGGER

Product: H11L1 H11L2 H11L3	Date: February 09, 2018	Page 18 of 18
	Version# 1.4	