



Chipsmall Limited consists of a professional team with an average of over 10 year of expertise in the distribution of electronic components. Based in Hongkong, we have already established firm and mutual-benefit business relationships with customers from,Europe,America and south Asia,supplying obsolete and hard-to-find components to meet their specific needs.

With the principle of "Quality Parts,Customers Priority,Honest Operation,and Considerate Service",our business mainly focus on the distribution of electronic components. Line cards we deal with include Microchip,ALPS,ROHM,Xilinx,Pulse,ON,Everlight and Freescale. Main products comprise IC,Modules,Potentiometer,IC Socket,Relay,Connector.Our parts cover such applications as commercial,industrial, and automotives areas.

We are looking forward to setting up business relationship with you and hope to provide you with the best service and solution. Let us make a better world for our industry!



Contact us

Tel: +86-755-8981 8866 Fax: +86-755-8427 6832

Email & Skype: info@chipsmall.com Web: www.chipsmall.com

Address: A1208, Overseas Decoration Building, #122 Zhenhua RD., Futian, Shenzhen, China



STEP 14

Please tighten with respect of the 0.39 in / 10 mm length

Visser en respectant bien la cote de 0.39 in / 10 mm

Atornillar con el respecto de la distancia de 0.39 in / 10 mm

30.9 - 33.6 lb-in
3,5 - 3,8 Nm
Allen key size 2.5
6 pans de 2,5

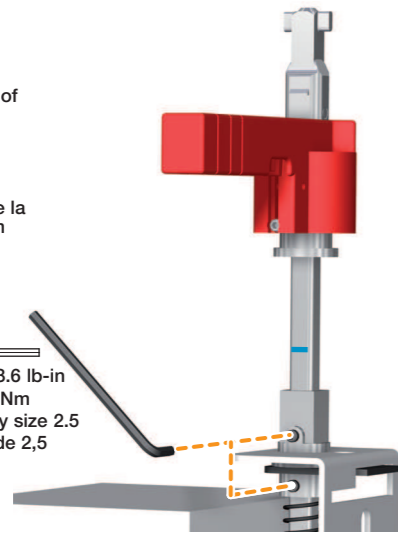

STEP 15

Set the position of the handle
Régler la position de la poignée
Reglar la posición de la mando

30.9 - 33.6 lb-in
3,5 - 3,8 Nm
Allen key size 2.5
6 pans de 2,5

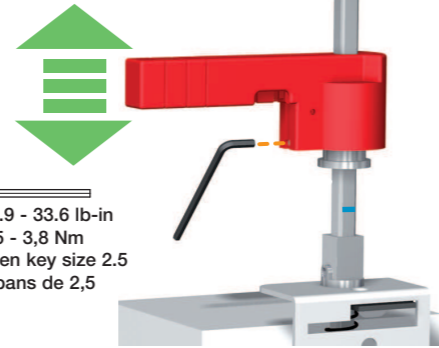

**OPEN TEST
TEST HORS COFFRET
TEST SIN CARGA**

**ENCLOSED TEST
TEST SOUS COFFRET
TEST EN UN CARGA**

1 Press
Appuyer
Apretar

2 Turn 90°
Tourner de 90°
Girar de 90°

3 The operation is possible only if the mounting has been well.

La manoeuvre est possible que si le montage a été bien effectué.

La rotación del mando solo es posible si el montaje ha sido bien hecho.

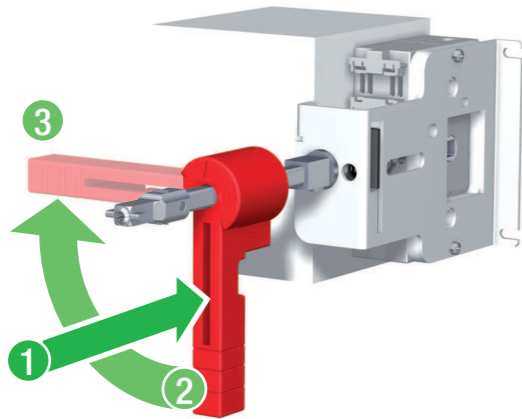

Please check H length when the product is in 0 (OFF) position
Le produit en position 0, vérifier la cote H
Cuando el producto esta en la posición 0, verificar la distancia H



min. 1.08 in
min. 27,5 mm
max. 1.24 in
max. 31,5 mm

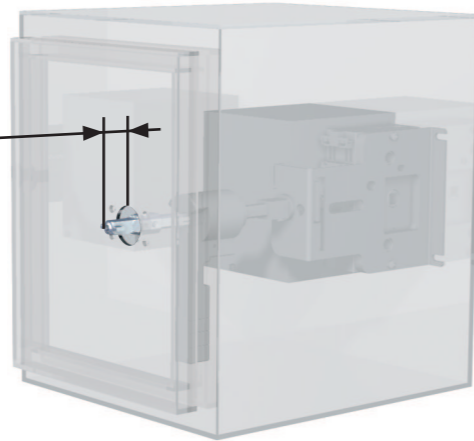

**PADLOCKING
CADENASSAGE
CANDADO**

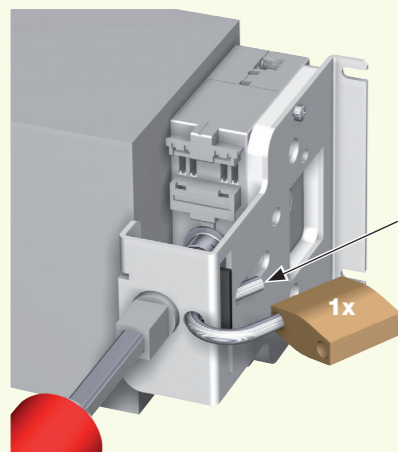

max. Ø 0.31 in / Ø 8 mm
min. Ø 0.19 in / Ø 5 mm

1x

⚠ DANGER / DANGER / PELIGRO

HAZARDOUS VOLTAGE

- This equipment must be installed and serviced only by qualified electrical personnel.
- Turn off all power supplying this equipment before working on or inside equipment.
- Always use a properly rated voltage sensing device to confirm power is OFF.
- Replace all devices, doors, and covers before turning on power to this equipment.
- Maintain electrical clearances between cable and live parts.

Failure to follow these instructions will result in death or serious injury.

TENSION DANGEREUSE

- L'installation et l'entretien de cet appareil ne doivent être effectués que par du personnel qualifié.
- Coupez l'alimentation de cet appareil avant d'y travailler.
- Utilisez toujours un dispositif de détection de tension à valeur nominale approprié pour confirmer que toute alimentation est coupée.
- Remplacez tous les dispositifs, les portes et les couvercles avant de mettre cet appareil sous tension.
- Maintenez les distances d'isolement électrique entre le câble et les pièces sous tension.

Si ces précautions ne sont pas respectées, cela entraînera la mort ou des blessures graves.

TENSION PELIGROSA

- Solamente el personal de mantenimiento eléctrico especializado deberá instalar y prestar servicios de mantenimiento a este equipo.
- Desenergice el equipo antes de realizar cualquier trabajo en él.
- Siempre utilice un dispositivo detector de tensión adecuado para confirmar la desenergización del equipo.
- Vuelva a colocar todos los dispositivos, las puertas y las cubiertas antes de energizar este equipo.
- Mantenga un espacio adecuado para la instalación eléctrica entre el cable y las piezas energizadas.

El incumplimiento de estas precauciones podrá causar la muerte o lesiones serias.

**NFPA kit
Kit NFPA
Opción NFPA**

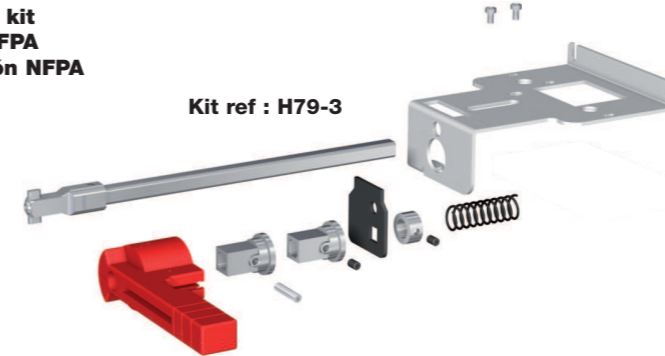

Kit ref : H79-3

**DANGER AND WARNING
DANGER ET AVERTISSEMENT - ADVERTENCIA**

This equipment must be mounted only by professionals. The manufacturer shall not be held responsible for failure to comply with the instructions in this manual.

Le montage de ces matériels ne peut être effectué que par des professionnels. Le non respect des indications de la présente notice ne saurait engager la responsabilité du constructeur.

El montaje de esto materiales sólo puede ser efectuado por profesionales. No respetar las indicaciones del presente manual exime de responsabilidad al fabricante.

**Mounting steps to respect
Etapas de montage à respecter
Respectar las etapas de montaje**



STEP 1

**Shaft preparation
Préparation de l'axe
Preparación del prologado**

SWITCHES REFERENCES		
RDF400J-2 / RDF400J-3 / RDF400J-4	STEP 12	 L min. = H - 3.09 in L min. = H - 78,5 mm L max. = H - 2.93 in L max. = H - 74,5 mm

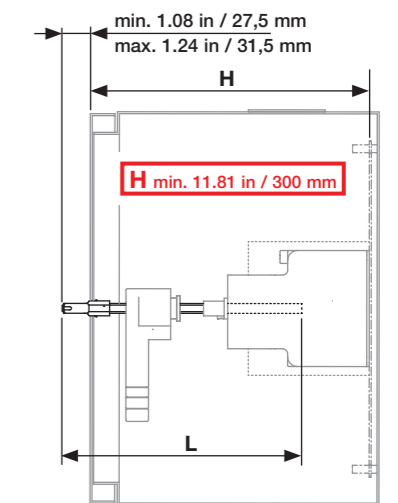

Dual dimensions in/mm
Double dimensions in/mm
Doble dimensiones in/mm

**Mounting
Montage
Montaje**

STEP 2

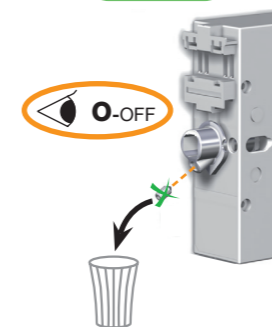

STEP 3

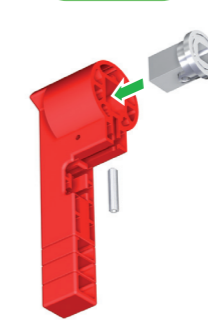

STEP 4

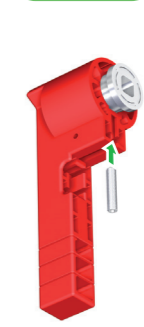

STEP 5



Tighten a little
Pré visser
Atornillar un poco

STEP 6

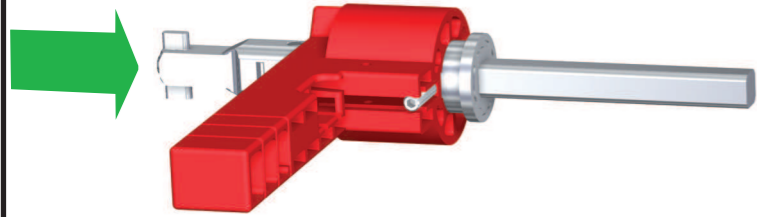

STEP 7

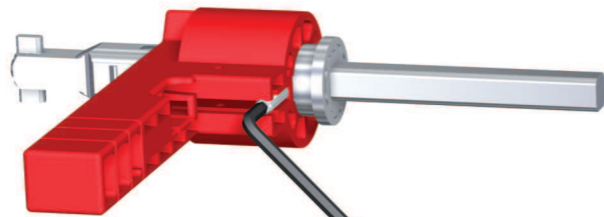

30.9 - 33.6 lb-in
3,5 - 3,8 Nm
Allen key size 2.5
6 pans de 2,5

STEP 8

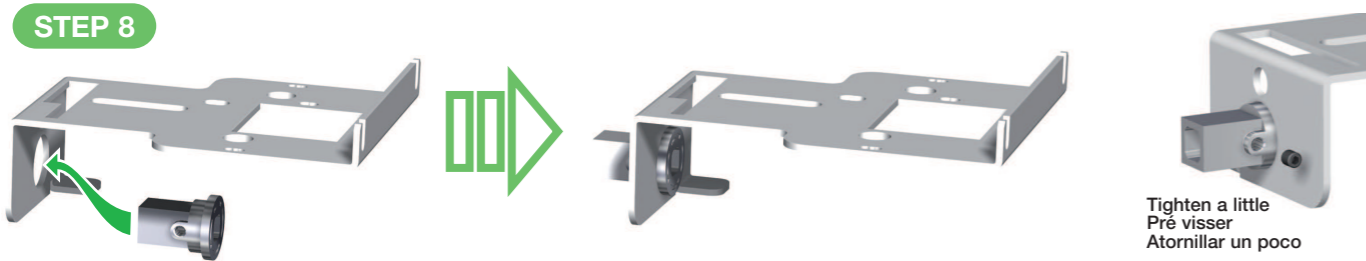

Tighten a little
Pré visser
Atornillar un poco

STEP 9

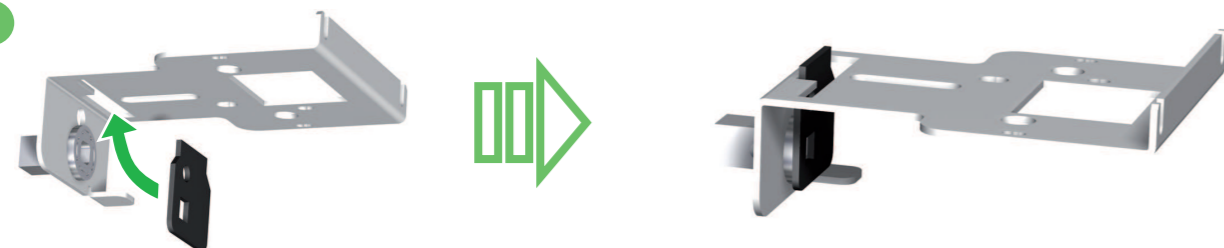

STEP 10

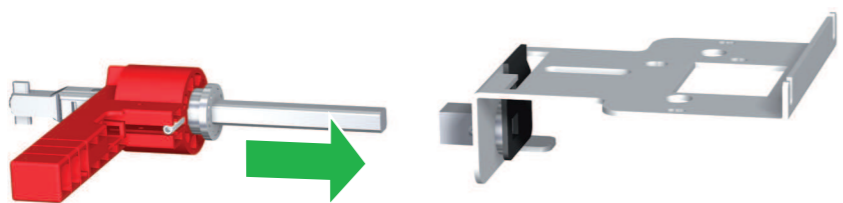

STEP 11

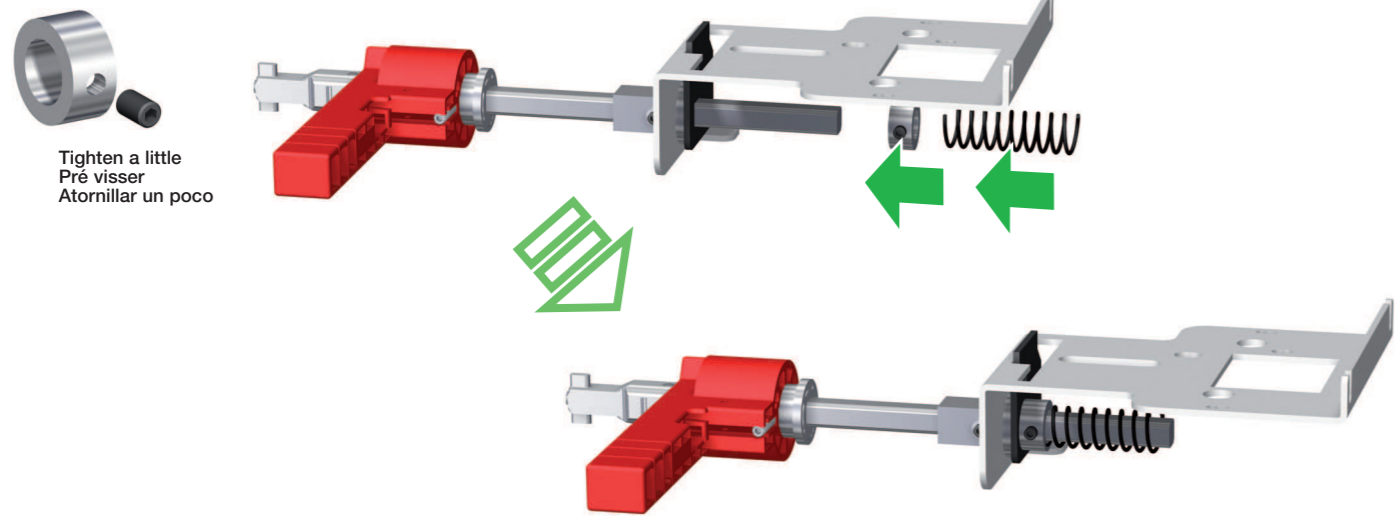

Tighten a little
Pré visser
Atornillar un poco

STEP 12

See page 1
Voir page 1
Véase pagina 1

The NFPA kit can be mounted on different products. Please check your configuration: spacer and tightening

Le kit NFPA peut se monter sur différents types de produits. Veiller à bien déterminer votre configuration: cale et vissage

La opción NFPA puede ser montada en diferentes productos. Por favor verifique su configuración: cuña y tornillería

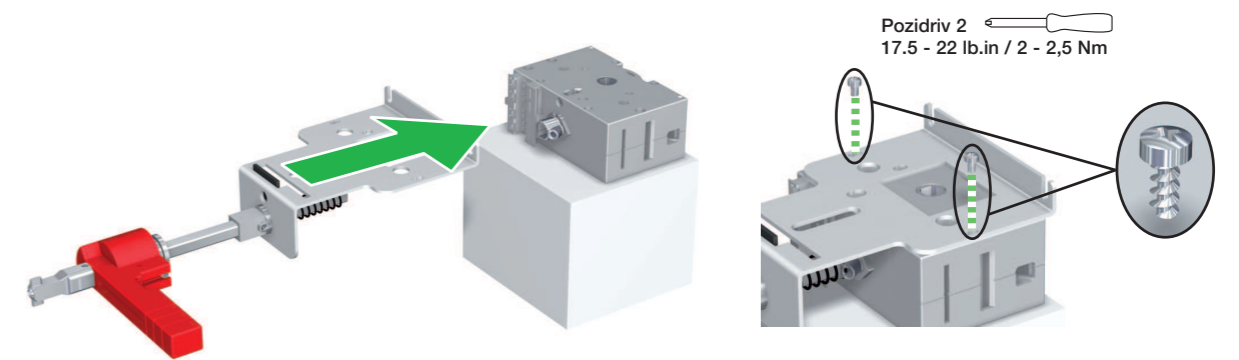

Pozidriv 2
17.5 - 22 lb.in / 2 - 2,5 Nm

STEP 13

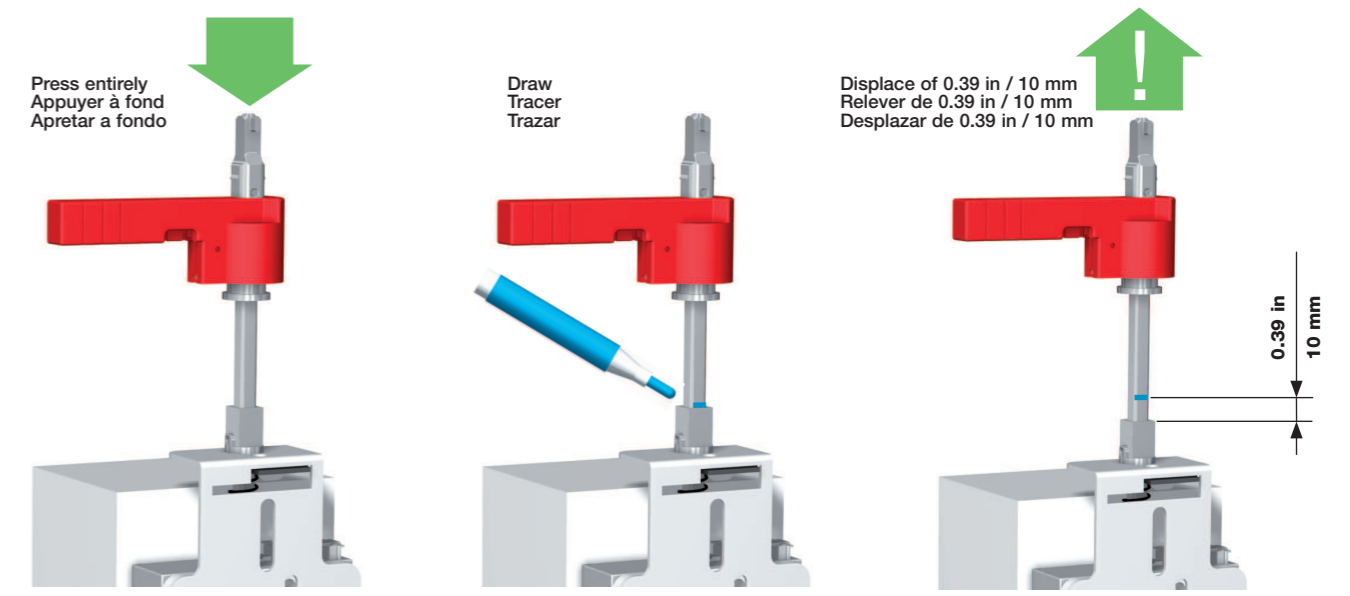

Press entirely
Appuyer à fond
Apretar a fondo

Draw
Tracer
Trazar

Displace of 0.39 in / 10 mm
Relever de 0.39 in / 10 mm
Desplazar de 0.39 in / 10 mm

0.39 in
10 mm