



Chipsmall Limited consists of a professional team with an average of over 10 year of expertise in the distribution of electronic components. Based in Hongkong, we have already established firm and mutual-benefit business relationships with customers from,Europe,America and south Asia,supplying obsolete and hard-to-find components to meet their specific needs.

With the principle of "Quality Parts,Customers Priority,Honest Operation,and Considerate Service",our business mainly focus on the distribution of electronic components. Line cards we deal with include Microchip,ALPS,ROHM,Xilinx,Pulse,ON,Everlight and Freescale. Main products comprise IC,Modules,Potentiometer,IC Socket,Relay,Connector.Our parts cover such applications as commercial,industrial, and automotives areas.

We are looking forward to setting up business relationship with you and hope to provide you with the best service and solution. Let us make a better world for our industry!



Contact us

Tel: +86-755-8981 8866 Fax: +86-755-8427 6832

Email & Skype: info@chipsmall.com Web: www.chipsmall.com

Address: A1208, Overseas Decoration Building, #122 Zhenhua RD., Futian, Shenzhen, China



REVISIONS

P	LTR	DESCRIPTION	DATE	DWN	APVD
A		INITIAL RELEASE	16DEC2014	DW	CW
B		ECR-15-013750	19SEP2015	DW	CW
B1		ECR-15-016224	05NOV2015	DW	CW
B2		ECR-16-017507	12DEC2016	QY	CW

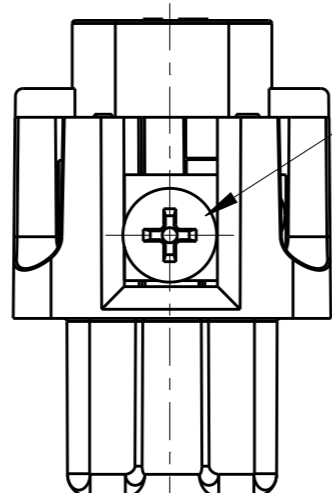
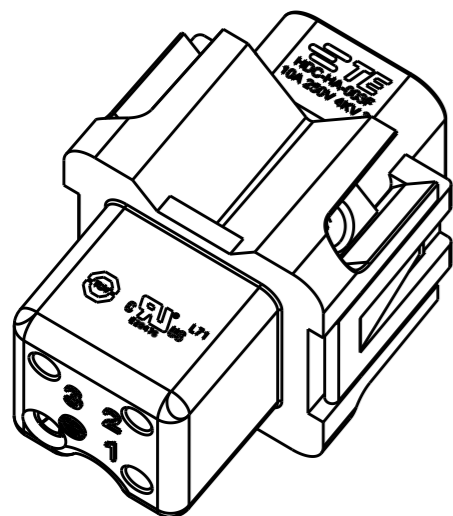

M3 SCREW, RECOMMENDED
TIGHTENING TORQUE 0.5Nm
M3 螺丝, 推荐锁紧力矩0.5Nm

TYPE-1, T2010032201-000, TE LOGO
类型-1, T2010032201-000, TE LOGO

NOTES:

- 1. TECHNICAL CHARACTERISTICS:
INSULATION MATERIAL: PC
RATED VOLTAGE: 250 V
RATED CURRENT: 10 A
INSULATION RESISTANCE: $\geq 400M\Omega$
RATED IMPULSE VOLTAGE: 4 KV
POLLUTION DEGREE: 3
FLAMMABILITY: UL94V-0
MATING CYCLES: 500 CYCLES
WIRE RANGE: 0.5-2.5 mm² (20-14 AWG)
CONTACT FINISH: SILVER PLATED
CONTACT TYPE: SCREW CONTACT

注释:

- 1. 技术参数:
绝缘材料: PC
额定电压: 250V
额定电流: 10A
绝缘电阻: $\geq 400M\Omega$
额定脉冲电压: 4 KV
污染等级: 3
阻燃等级: UL94V-0
插拔次数: 500 次
接线范围: 0.5-2.5 mm² (20-14 AWG)
端子表面处理: 镀银
接线类型: 螺丝连接

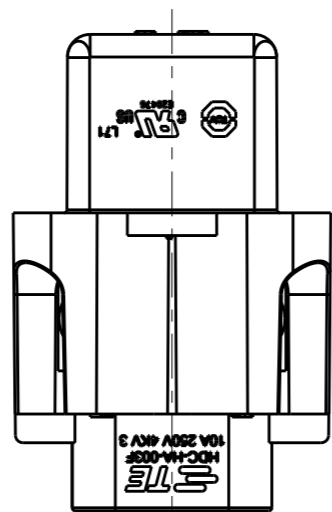
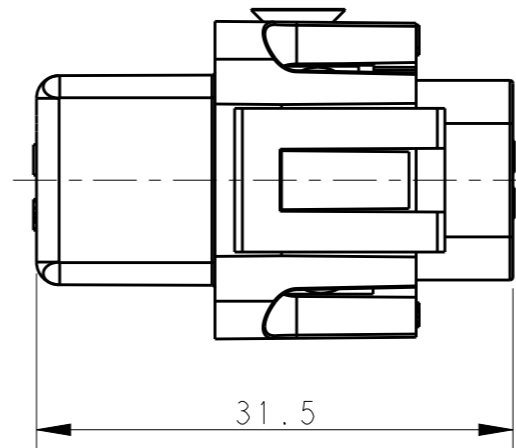
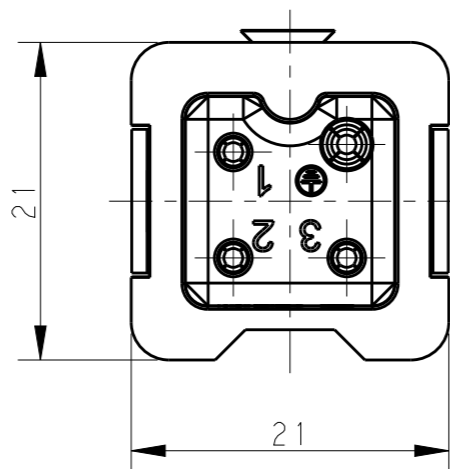

THIS DRAWING IS A CONTROLLED DOCUMENT.

DIMENSIONS:
mm

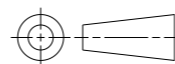

TOLERANCES UNLESS OTHERWISE SPECIFIED:

0 PLC	±-
1 PLC	±-
2 PLC	±-
3 PLC	±-
4 PLC	±-
ANGLES	±-

MATERIAL
-

FINISH
-

DWN 16DEC2014
DAVID WANG
CHK 16DEC2014
CHRIS WANG
APVD 16DEC2014
XU XIANG

PRODUCT SPEC
108-137045
APPLICATION SPEC
114-137045
WEIGHT
-



NAME
HA-003-F

SIZE	CAGE CODE	DRAWING NO	RESTRICTED TO
A3	00779	©-T2010032201000	-

Customer Drawing SCALE 2:1 SHEET 1 OF 2 REV B2

THIS DRAWING IS UNPUBLISHED.

RELEASED FOR PUBLICATION

20

© COPYRIGHT 20 BY -

ALL RIGHTS RESERVED.

REVISIONS

P	LTR	DESCRIPTION	DATE	DWN	APVD
-	-	SEE SHEET 1	-	-	-

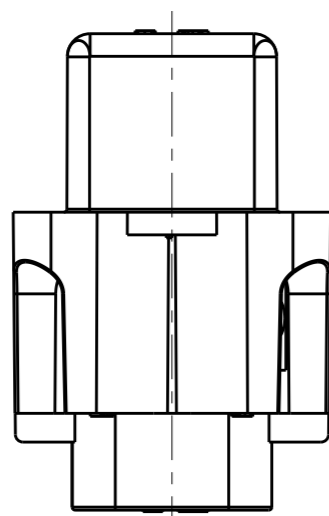
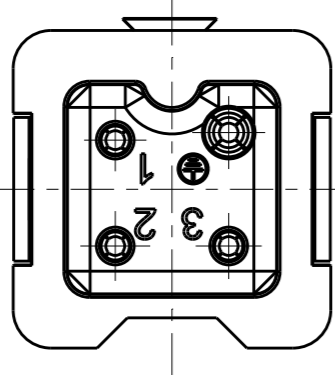
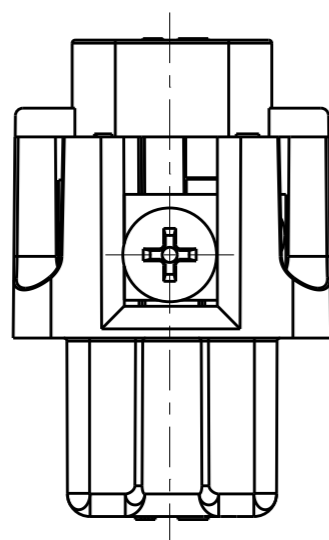

ALL DIMENSIONS ARE SAME AS TYPE 1,
EXCEPT THOSE DEFINED IN THIS TYPE.
除了在本类型中定义的尺寸外, 其它尺寸同类型 1

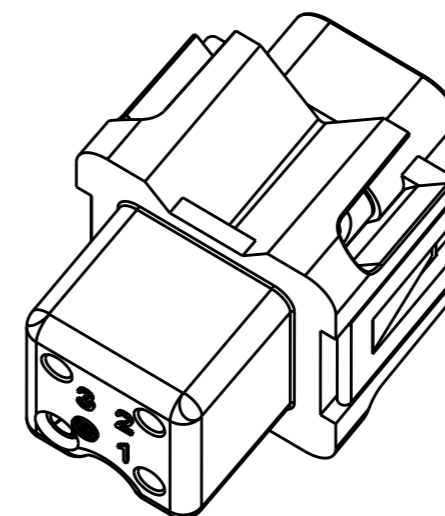
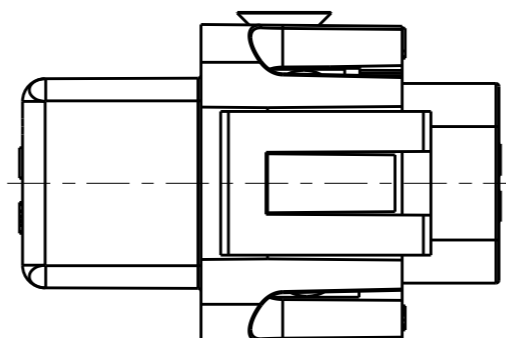

TYPE-2, T2010032201-001, NO LOGO
类型-2, T2010032201-001, 无 LOGO

NOTE:
SEE SHEET 1
注释:
见页 1

T2010032201-001	HA-003-F	HA-003 FEMALE INSERT, NO LOGO HA-003母插, 无LOGO	TYPE-2 类型-2
T2010032201-000	HA-003-F	HA-003 FEMALE INSERT HA-003母插	TYPE-1 类型-1
PART NUMBER 料号		PART DESCRIPTION 描述	TYPE 类型

THIS DRAWING IS A CONTROLLED DOCUMENT.		DWN 16DEC2014 DAVID WANG		
DIMENSIONS: mm		CHK 16DEC2014 CHRIS WANG		
TOLERANCES UNLESS OTHERWISE SPECIFIED:		APVD 16DEC2014 XU XIANG	NAME HA-003-F	
0 PLC ±-		PRODUCT SPEC 108-137045	SIZE CAGE CODE DRAWING NO RESTRICTED TO	
1 PLC ±-		APPLICATION SPEC 114-137045	A300779 © T2010032201000	
2 PLC ±-		WEIGHT -	SCALE 2:1 SHEET 2 OF 2 REV B2	
3 PLC ±-		Customer Drawing		
4 PLC ±-				
ANGLES ±-				
FINISH -				
MATERIAL -				