



Chipsmall Limited consists of a professional team with an average of over 10 year of expertise in the distribution of electronic components. Based in Hongkong, we have already established firm and mutual-benefit business relationships with customers from,Europe,America and south Asia,supplying obsolete and hard-to-find components to meet their specific needs.

With the principle of “Quality Parts,Customers Priority,Honest Operation,and Considerate Service”,our business mainly focus on the distribution of electronic components. Line cards we deal with include Microchip,ALPS,ROHM,Xilinx,Pulse,ON,Everlight and Freescale. Main products comprise IC,Modules,Potentiometer,IC Socket,Relay,Connector.Our parts cover such applications as commercial,industrial, and automotives areas.

We are looking forward to setting up business relationship with you and hope to provide you with the best service and solution. Let us make a better world for our industry!



Contact us

Tel: +86-755-8981 8866 Fax: +86-755-8427 6832

Email & Skype: info@chipsmall.com Web: www.chipsmall.com

Address: A1208, Overseas Decoration Building, #122 Zhenhua RD., Futian, Shenzhen, China



Data Sheet

HAL[®] 320

Differential Hall-Effect Sensor
IC Family

Copyright, Warranty, and Limitation of Liability

The information and data contained in this document are believed to be accurate and reliable. The software and proprietary information contained therein may be protected by copyright, patent, trademark and/or other intellectual property rights of Micronas. All rights not expressly granted remain reserved by Micronas.

Micronas assumes no liability for errors and gives no warranty representation or guarantee regarding the suitability of its products for any particular purpose due to these specifications.

By this publication, Micronas does not assume responsibility for patent infringements or other rights of third parties which may result from its use. Commercial conditions, product availability and delivery are exclusively subject to the respective order confirmation.

Any information and data which may be provided in the document can and do vary in different applications, and actual performance may vary over time.

All operating parameters must be validated for each customer application by customers' technical experts. Any new issue of this document invalidates previous issues. Micronas reserves the right to review this document and to make changes to the document's content at any time without obligation to notify any person or entity of such revision or changes. For further advice please contact us directly.

Do not use our products in life-supporting systems, aviation and aerospace applications! Unless explicitly agreed to otherwise in writing between the parties, Micronas' products are not designed, intended or authorized for use as components in systems intended for surgical implants into the body, or other applications intended to support or sustain life, or for any other application in which the failure of the product could create a situation where personal injury or death could occur.

No part of this publication may be reproduced, photocopied, stored on a retrieval system or transmitted without the express written consent of Micronas.

Micronas Trademarks

– HAL

Patents

Choppered Offset Compensation protected by Micronas patents no. US5406202A.

Third-Party Trademarks

All other brand and product names or company names may be trademarks of their respective companies.

Contents

Page	Section	Title
4	1.	Introduction
4	1.1.	Features:
4	1.2.	Marking Code
4	1.3.	Operating Junction Temperature Range (TJ)
5	1.4.	Hall Sensor Package Codes
5	1.5.	Solderability and Welding
5	1.6.	Pin Connections
6	2.	Functional Description
7	3.	Specifications
7	3.1.	Outline Dimensions
12	3.2.	Dimensions of Sensitive Area
12	3.3.	Package Parameters and Position of Sensitive Areas
12	3.4.	Absolute Maximum Ratings
12	3.4.1.	Storage and Shelf Life
13	3.5.	Recommended Operating Conditions
13	3.6.	Characteristics
15	3.7.	Magnetic Characteristics
20	4.	Application Notes
20	4.1.	Ambient Temperature
20	4.2.	Extended Operating Conditions
20	4.3.	Start-up Behavior
21	4.4.	EMC and ESD
22	5.	Data Sheet History

Differential Hall-Effect Sensor IC

Release Note: Revision bars indicate significant changes to the previous edition.

1. Introduction

The HAL 320 is a differential Hall switch produced in CMOS technology. The sensor includes two temperature-compensated Hall plates (2.25 mm apart) with active offset compensation, a differential amplifier with a Schmitt trigger, and an open-drain output transistor (see Fig. 2–1).

The HAL 320 is a differential sensor which responds to spatial differences of the magnetic field. The Hall voltages at the two Hall plates, S1 and S2, are amplified with a differential amplifier. The differential signal is compared with the actual switching level of the internal Schmitt trigger. Accordingly, the output transistor is switched on or off.

The sensor has a bipolar switching behavior and requires positive and negative values of $\Delta B = BS1 - BS2$ for correct operation.

Basically, there are two ways to generate the differential signal ΔB :

Rotating a multi-pole-ring in front of the branded side of the package (see Fig. 3–1, Fig. 3–2, and Fig. 3–3; Please use HAL 300 only).

- Back-bias applications: A magnet on the back side of the package generates a back-bias field at both Hall plates. The differential signal ΔB results from the magnetic modulation of the back-bias field by a rotating ferromagnetic target (Please use HAL 320 only).

The active offset compensation leads to constant magnetic characteristics over supply voltage and temperature.

The sensor is designed for industrial and automotive applications and operates with supply voltages from 4.5 V to 24 V in the ambient temperature range from –40 °C up to 150 °C.

The HAL 320 is an ideal sensor for target wheel applications, ignition timing, anti-lock brake systems, and revolution counting in extreme automotive and industrial environments

The HAL 320 is available in the SMD-package SOT89B-2 and in the leaded versions TO92UA-3 and TO92UA-4.

1.1. Features:

- Distance between Hall plates: 2.25 mm
- Operates from 4.5 V to 24 V supply voltage
- Switching offset compensation at 62 kHz
- Overvoltage protection
- Reverse-voltage protection at V_{DD} -pin
- Short-circuit protected open-drain output by thermal shutdown
- Operates with magnetic fields from DC to 10 kHz
- Output turns low with magnetic south pole on branded side of package and with a higher magnetic flux density in sensitive area S1 as in S2
- On-chip temperature compensation circuitry minimizes shifts of the magnetic parameters over temperature and supply voltage range
- The decrease of magnetic flux density caused by rising temperature in the sensor system is compensated by a built-in negative temperature coefficient of hysteresis

1.2. Marking Code

All Hall sensors have a marking on the package surface (branded side). This marking includes the name of the sensor and the temperature range.

Type	Temperature Range		
	A	I	C
HAL 320	320A	320I	320C

1.3. Operating Junction Temperature Range (T_J)

The Hall sensors from Micronas are specified to the chip temperature (junction temperature T_J).

The HAL 320 is available in following temperature ranges:

A: $T_J = -40\text{ °C to }+170\text{ °C}$

I: $T_J = -20\text{ °C to }+125\text{ °C}$

C: $T_J = 0\text{ °C to }+85\text{ °C}$

The relationship between ambient temperature (T_A) and junction temperature (T_J) is explained in section 4.1. on page 20.

1.4. Hall Sensor Package Codes

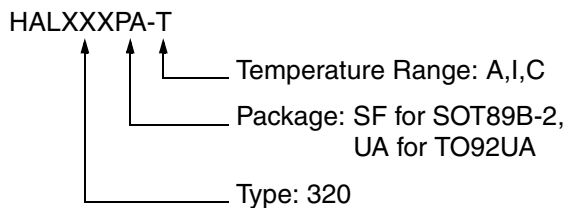

Example: **HAL320UA-A**

- Type: 320
- Package: TO92UA
- Temperature Range: $T_J = -40\text{ °C to }+170\text{ °C}$

Hall sensors are available in a wide variety of packaging versions and quantities. For more detailed information, please refer to the brochure: “Hall Sensors. Ordering Codes, Packaging, Handling”.

1.5. Solderability and Welding

Soldering

During soldering reflow processing and manual reworking, a component body temperature of 260 °C should not be exceeded.

Welding

Device terminals should be compatible with laser and electrical resistance welding. Please, note that the success of the welding process is subject to different welding parameters which will vary according to the welding technique used. A very close control of the welding parameters is absolutely necessary in order to reach satisfying results. Micronas, therefore, does not give any implied or express warranty as to the ability to weld the component.

1.6. Pin Connections

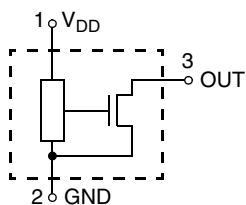

Fig. 1–1: Pin configuration

2. Functional Description

This Hall effect sensor is a monolithic integrated circuit with two Hall plates 2.25 mm apart that switches in response to differential magnetic fields. If magnetic fields with flux lines perpendicular to the sensitive areas are applied to the sensor, the biased Hall plates force Hall voltages proportional to these fields. The difference of the Hall voltages is compared with the actual threshold level in the comparator. The temperature-dependent bias increases the supply voltage of the Hall plates and adjusts the switching points to the decreasing induction of magnets at higher temperatures. If the differential magnetic field exceeds the threshold levels, the open drain output switches to the appropriate state. The builtin hysteresis eliminates oscillation and provides switching behavior of the output without oscillation.

Magnetic offset caused by mechanical stress at the Hall plates is compensated for by using the “switching offset compensation technique”: An internal oscillator provides a two phase clock (see Fig. 2–2). The difference of the Hall voltages is sampled at the end of the first phase. At the end of the second phase, both sampled differential Hall voltages are averaged and compared with the actual switching point. Subsequently, the open drain output switches to the appropriate state. The amount of time that elapses from crossing the magnetic switch level to the actual switching of the output can vary between zero and $1/f_{osc}$.

Shunt protection devices clamp voltage peaks at the Output-Pin and V_{DD} -Pin together with external series resistors. Reverse current is limited at the V_{DD} -Pin by an internal series resistor up to -15 V . No external reverse protection diode is needed at the V_{DD} -Pin for values ranging from 0 V to -15 V .

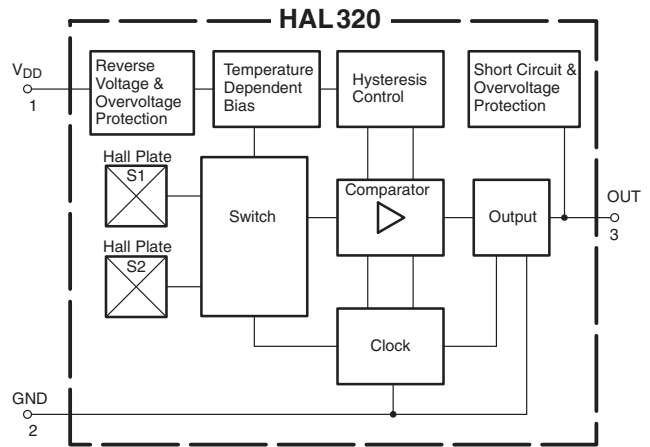

Fig. 2–1: HAL 320 block diagram

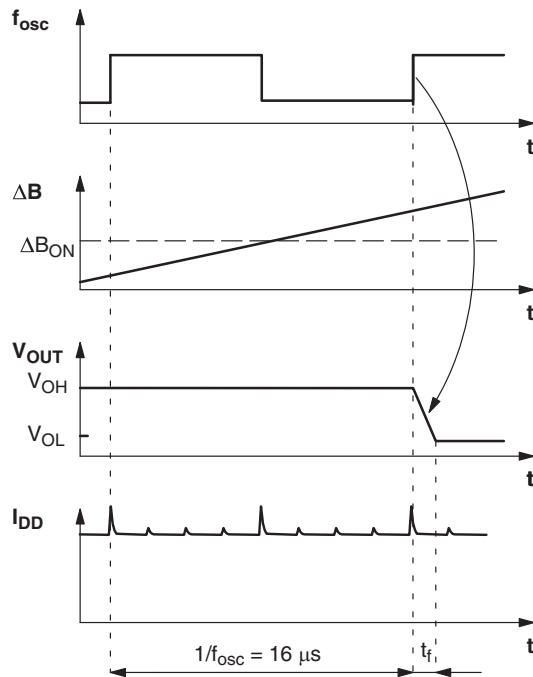

Fig. 2–2: Timing diagram

3. Specifications

3.1. Outline Dimensions

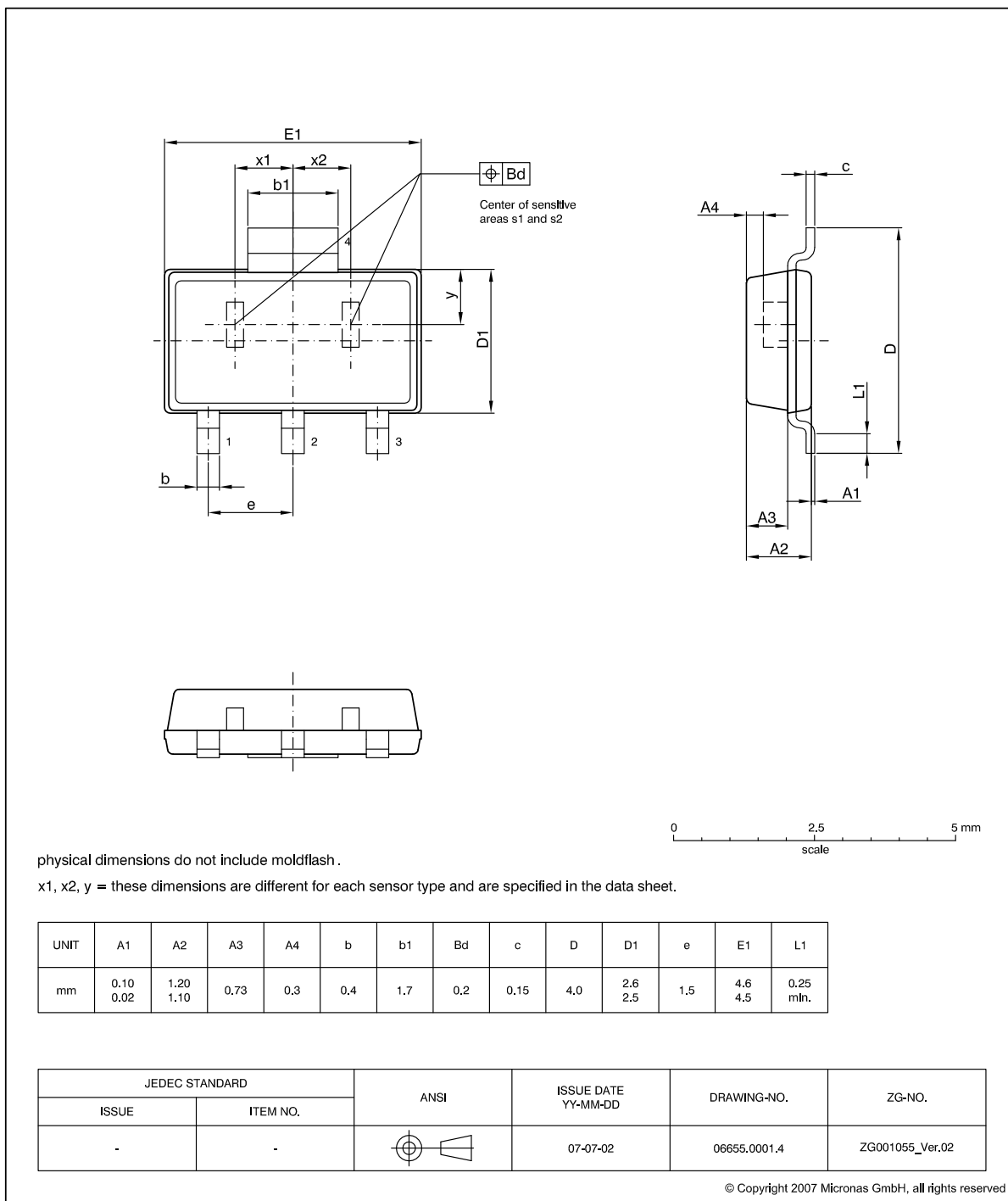

Fig. 3-1:
SOT89B-2: Plastic Small Outline Transistor package, 4 leads, with two sensitive areas
 Ordering code: SF
 Weight approximately 0.034 g

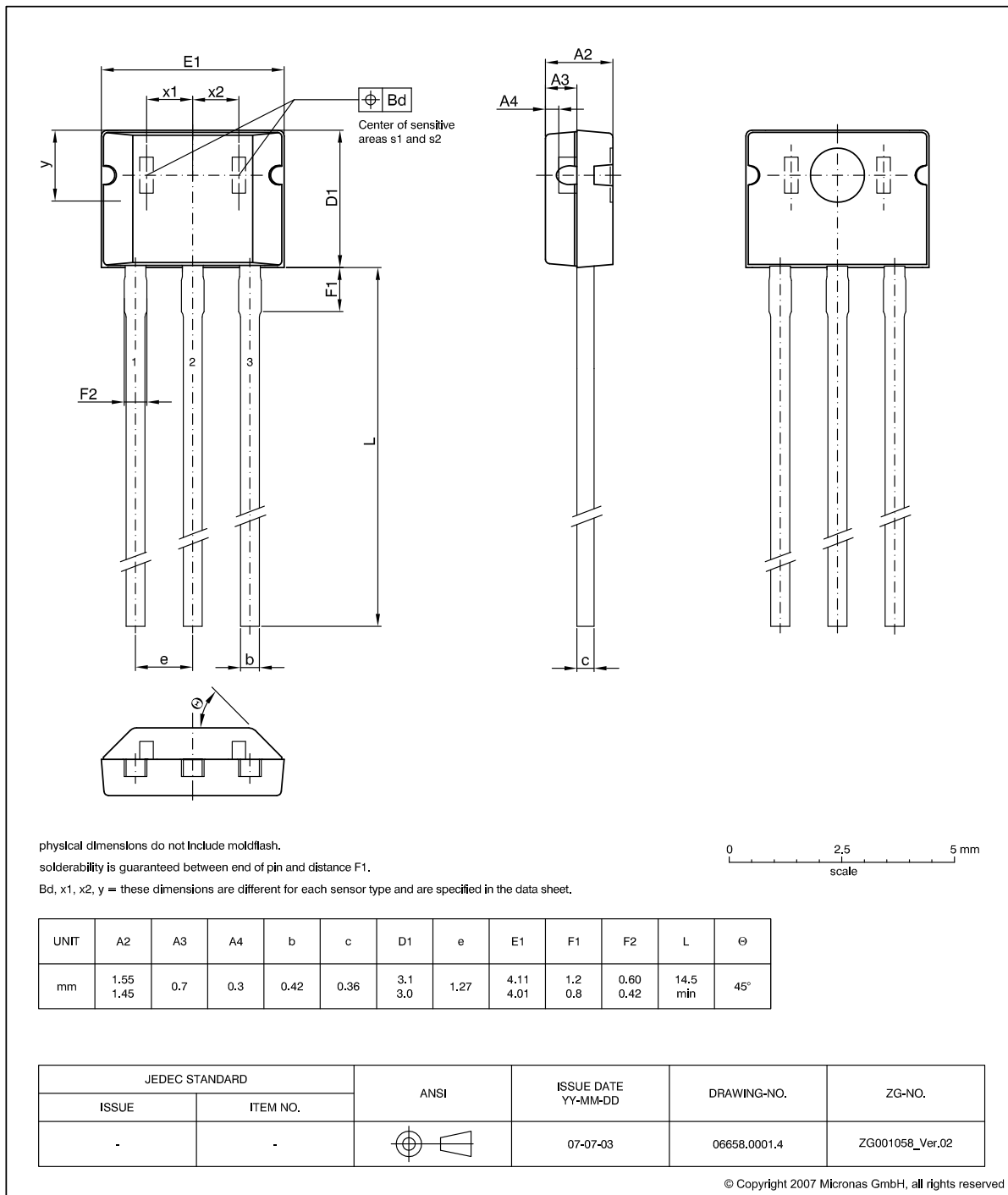

Fig. 3-2:
TO92UA-4: Plastic Transistor Standard UA package, 3 leads, spread
Weight approximately 0.105 g

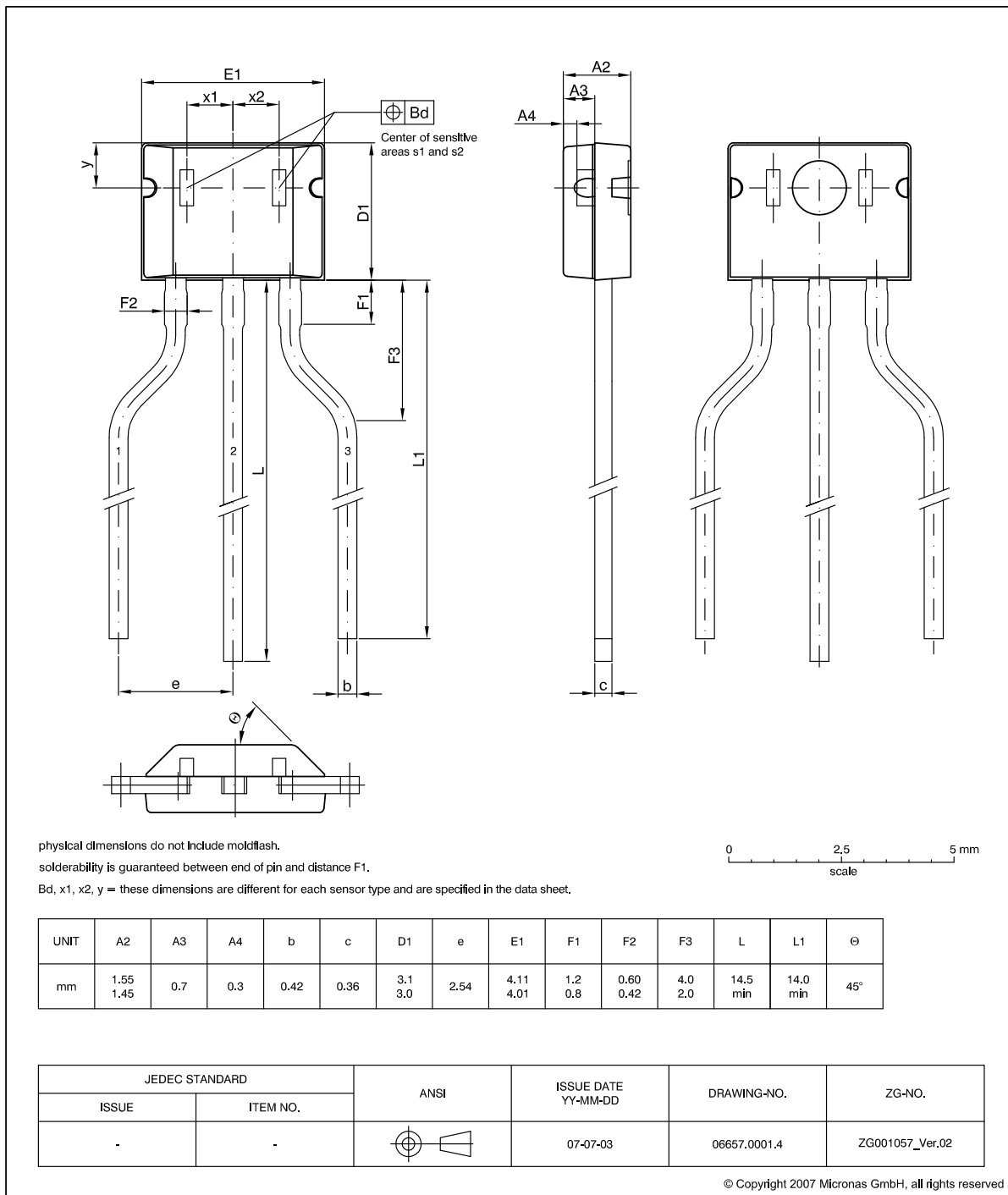

Fig. 3-3:
TO92UA-3: Plastic Transistor Standard UA package, 3 leads, spread
Weight approximately 0.105 g

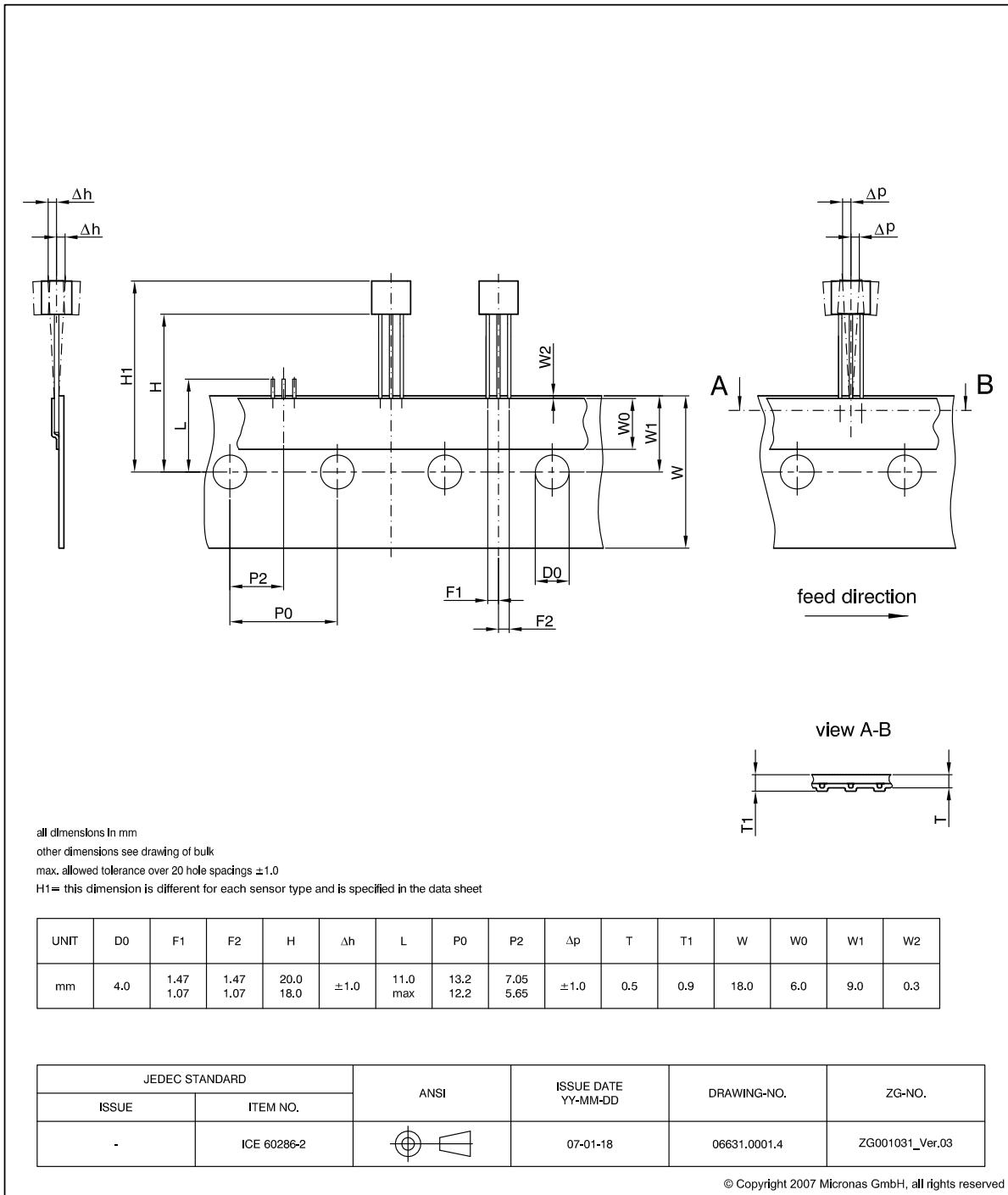

Fig. 3-4:
TO92UA/UT: Dimensions ammpack inline, not spread

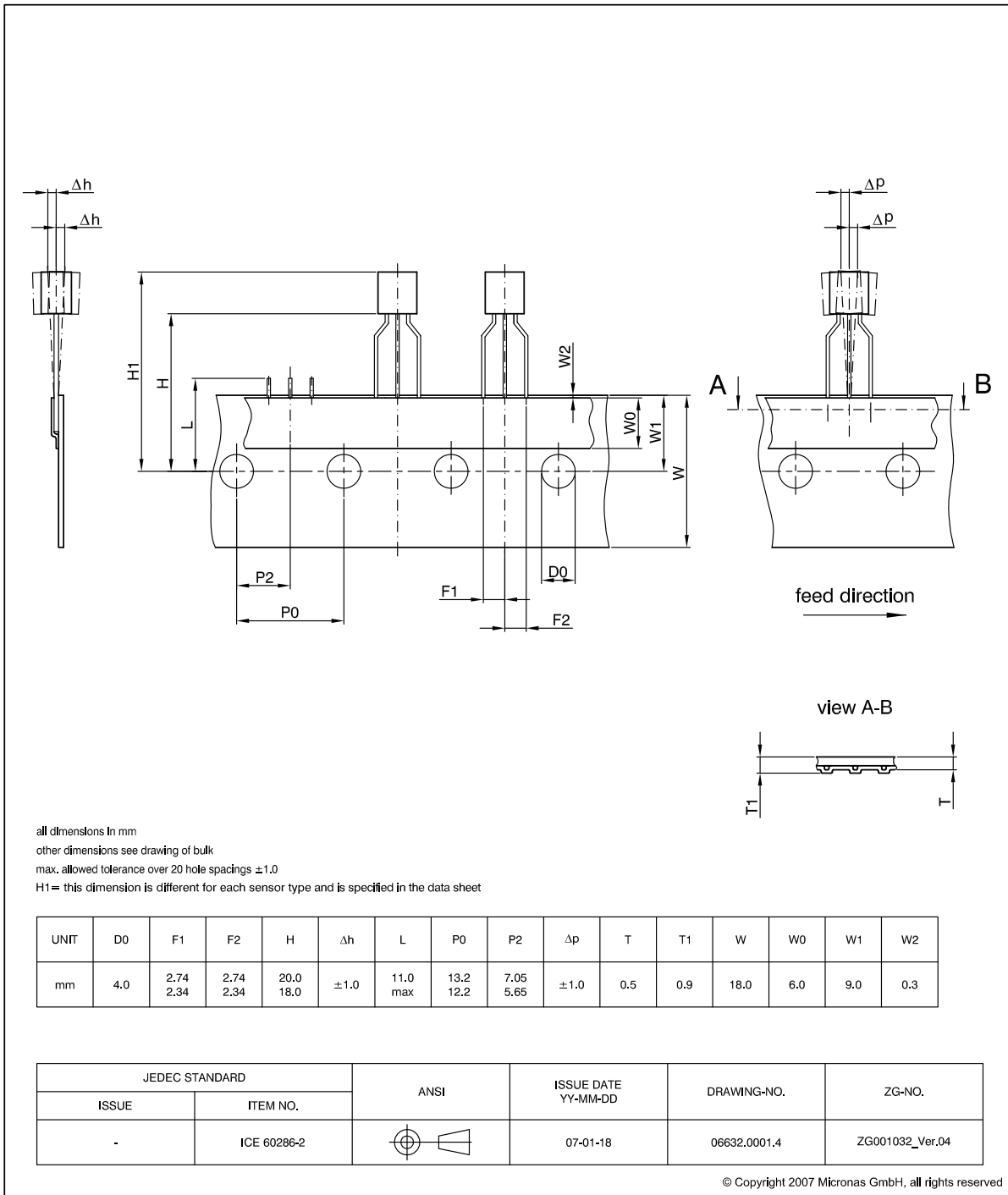

Fig. 3-5:
TO92UA/UT: Dimensions ammpack inline, spread

3.2. Dimensions of Sensitive Area

0.08 mm × 0.17 mm

3.3. Package Parameters and Position of Sensitive Areas

SOT89B-2	TO92UA-3/-4
$x_1 = -1.125$ mm (nominal values)	
$x_2 = 1.125$ mm (nominal values)	
$x_1 - x_2 = 2.25$ mm (nominal values)	
$y = 0.95$ mm (nominal values)	$y = 1.0$ mm (nominal values)
$Bd = 0.2$ mm	
n.a.	H1= min. 21 mm max. 23 mm

3.4. Absolute Maximum Ratings

Stresses beyond those listed in the “Absolute Maximum Ratings” may cause permanent damage to the device. This is a stress rating only. Functional operation of the device at these conditions is not implied. Exposure to absolute maximum rating conditions for extended periods will affect device reliability.

This device contains circuitry to protect the inputs and outputs against damage due to high static voltages or electric fields; however, it is advised that normal precautions be taken to avoid application of any voltage higher than absolute maximum-rated voltages to this high-impedance circuit.

All voltages listed are referenced to ground (GND).

Symbol	Parameter	Pin Name	Min.	Max.	Unit
V_{DD}	Supply Voltage	1	-15	28 ¹⁾	V
V_O	Output Voltage	3	-0.3	28 ¹⁾	V
I_O	Continuous Output On Current	3	-	30	mA
T_J	Junction Temperature Range		-40 -40	150 170 ²⁾	°C
¹⁾ as long as T_{Jmax} is not exceeded ²⁾ $t < 1000$ h					

3.4.1. Storage and Shelf Life

The permissible storage time (shelf life) of the sensors is unlimited, provided the sensors are stored at a maximum of 30 °C and a maximum of 85% relative humidity. At these conditions, no Dry Pack is required.

Solderability is guaranteed for one year from the date code on the package.

3.5. Recommended Operating Conditions

Functional operation of the device beyond those indicated in the “Recommended Operating Conditions/Characteristics” is not implied and may result in unpredictable behavior, reduce reliability and lifetime of the device.

All voltages listed are referenced to ground (GND).

Symbol	Parameter	Pin Name	Min.	Max.	Unit
V_{DD}	Supply Voltage	1	4.5	24	V
I_O	Continuous Output on Current	3	–	20	mA
V_O	Output Voltage	3	–	24	V

3.6. Characteristics

at $T_J = -40\text{ °C}$ to $+170\text{ °C}$, $V_{DD} = 4.5\text{ V}$ to 24 V , $GND = 0\text{ V}$

at Recommended Operation Conditions if not otherwise specified in the column “Conditions”.

Typical Characteristics for $T_J = 25\text{ °C}$ and $V_{DD} = 12\text{ V}$.

For all other temperatur ranges this table is also valid, but only in the junction temperature range defined by the temperatur grade (Example: For C-Type this table is limited to $T_J = 0\text{ °C}$ to $+85\text{ °C}$).

Symbol	Parameter	Pin No.	Min.	Typ.	Max.	Unit	Conditions
I_{DD}	Supply Current	1	2.8	4.7	6.8	mA	$T_J = 25\text{ °C}$
I_{DD}	Supply Current over Temperature Range	1	1.8	4.7	7.5	mA	
V_{DDZ}	Overvoltage Protection at Supply	1	–	28.5	32.5	V	$I_{DD} = 25\text{ mA}$, $T_J = 25\text{ °C}$, $t = 20\text{ ms}$
V_{OZ}	Overvoltage Protection at Output	3	–	28	32.5	V	$I_{OH} = 25\text{ mA}$, $T_J = 25\text{ °C}$, $t = 20\text{ ms}$
V_{OL}	Output Voltage over Temperature Range	3	–	180	400	mV	$I_{OL} = 20\text{ mA}$
I_{OH}	Output Leakage Current over Temperature Range	3	–	0.06	10	μA	$V_{OH} = 4.5\text{ V} \dots 24\text{ V}$, $\Delta B < \Delta B_{OFF}$, $T_J \leq 150\text{ °C}$,
f_{osc}	Internal Oscillator Chopper Frequency	–	–	62	–	kHz	
$t_{en(O)}$	Enable Time of Output after Setting of V_{DD}	3	–	35	–	μs	$V_{DD} = 12\text{ V}$, $\Delta B > \Delta B_{ON} + 2\text{ mT}$ or $\Delta B < \Delta B_{OFF} - 2\text{ mT}$
t_r	Output Rise Time	3	–	80	400	ns	$V_{DD} = 12\text{ V}$, $R_L = 820\ \Omega$, $C_L = 20\text{ pF}$
t_f	Output Fall Time	3	–	45	400	ns	$V_{DD} = 12\text{ V}$, $R_L = 820\ \Omega$, $C_L = 20\text{ pF}$
$R_{th_{JSB}}$ case SOT89B-2	Thermal Resistance Junction to Substrate Backside		–	150	200	K/W	Fiberglass Substrate 30 mm x 10 mm x 1.5 mm (see Fig. 3–6)
$R_{th_{JS}}$ case TO92UA-3 TO92UA-4	Thermal Resistance Junction to Soldering Point		–	150	200	K/W	

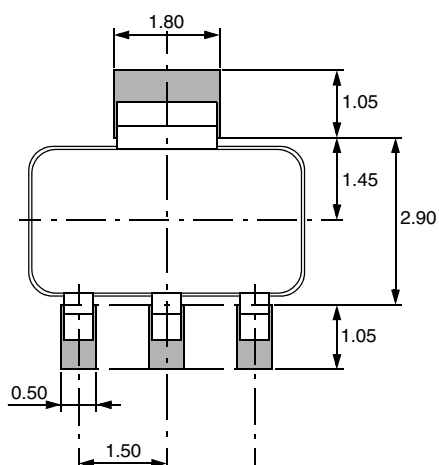

Fig. 3-6: Recommended footprint SOT89B,
Dimensions in mm

Note: All dimensions are for reference only. The pad size may vary depending on the requirements of the soldering process.

3.7. Magnetic Characteristics

at $T_J = -40\text{ °C}$ to $+170\text{ °C}$, $V_{DD} = 4.5\text{ V}$ to 24 V ,
 Typical Characteristics for $V_{DD} = 12\text{ V}$.

Magnetic flux density values of switching points (Condition: $-10\text{ mT} < B_0 < 10\text{ mT}$).

Positive flux density values refer to the magnetic south pole at the branded side of the package. $\Delta B = B_{S1} - B_{S2}$

Parameter	-40 °C			25 °C			85 °C			125 °C			170 °C			Unit
	Min.	Typ.	Max	Min.	Typ.	Max	Min.	Typ.	Max	Min.	Typ.	Max	Min.	Typ.	Max	
On point ΔB_{ON} $\Delta B > \Delta B_{ON}$	-1.5	1.2	2.5	-1.5	1.2	2.5	-2.5	1.1	3.5	-2.5	1.1	3.5	-2.5	1.1	3.5	mT
Off point ΔB_{OFF} $\Delta B > \Delta B_{OFF}$	-2.5	-0.6	1.5	-2.5	-0.6	1.5	-3.5	-0.4	2.5	-3.5	-0.4	2.5	-3.5	-0.4	2.5	mT
Hysteresis $\Delta B_{HYS} = \Delta B_{ON} - \Delta B_{OFF}$	1	1.8	4	1	1.8	4	0.8	1.5	4	0.8	1.5	4	0.8	1.5	4	mT
Offset $\Delta B_{OFFSET} = (\Delta B_{ON} + \Delta B_{OFF})/2$	-2	0.3	2	-2	0.3	2	-3	0.4	3	-3	0.4	3	-3	0.4	3	mT

In back-biased applications, sensitivity mismatch between the two Hall plates S_1 and S_2 can lead to an additional offset of the magnetic switching points. In back-biased applications with the magnetic preinduction B_0 , this sensitivity mismatch generates the magnetic offset $\Delta B_{OFFSETbb} = |S1 - S2|/S1 \cdot B_0 + \Delta B_{OFFSET}$.

Parameter	-40 °C	25 °C	170 °C	Unit
Sensitivity mismatch ¹⁾ $ S1 - S2 /S1$	1.5 ²⁾	1.0 ²⁾	0.5 ²⁾	%
¹⁾ Mechanical stress from packaging can influence sensitivity mismatch. ²⁾ All values are typical values.				

The magnetic switching points are checked at room temperature at a magnetic preinduction of $B_0 = 150\text{ mT}$. These magnetic parameters may change under external pressure and during the lifetime of the sensor.

Parameter	25 °C			Unit
	Min.	Typ.	Max.	
On point ΔB_{ONbb}	-4.5	1.5	5.5	mT
Off point ΔB_{OFFbb}	-5.5	-0.3	4.5	mT
Hysteresis ΔB_{HYS}	1	1.8	4	mT
Offset $\Delta B_{OFFSETbb}$	-5	0.6	+5	mT

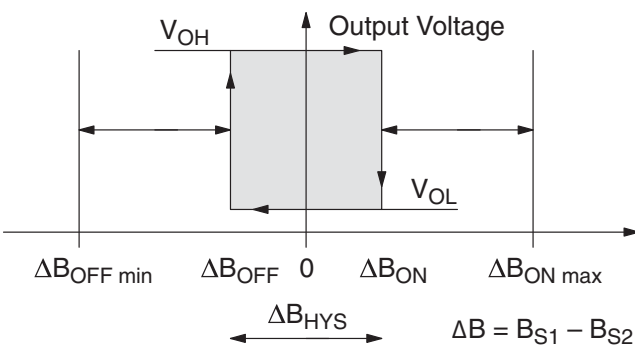
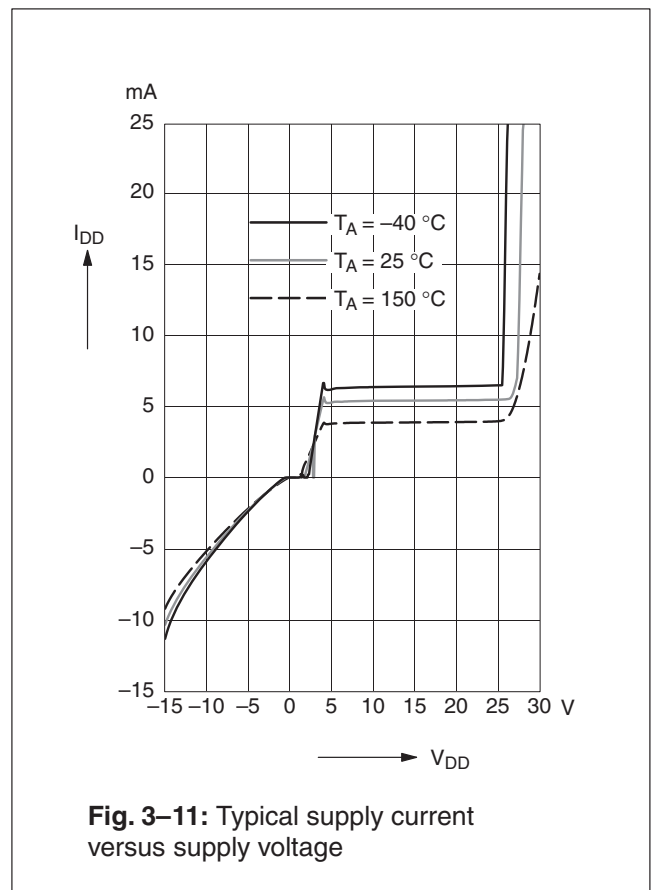
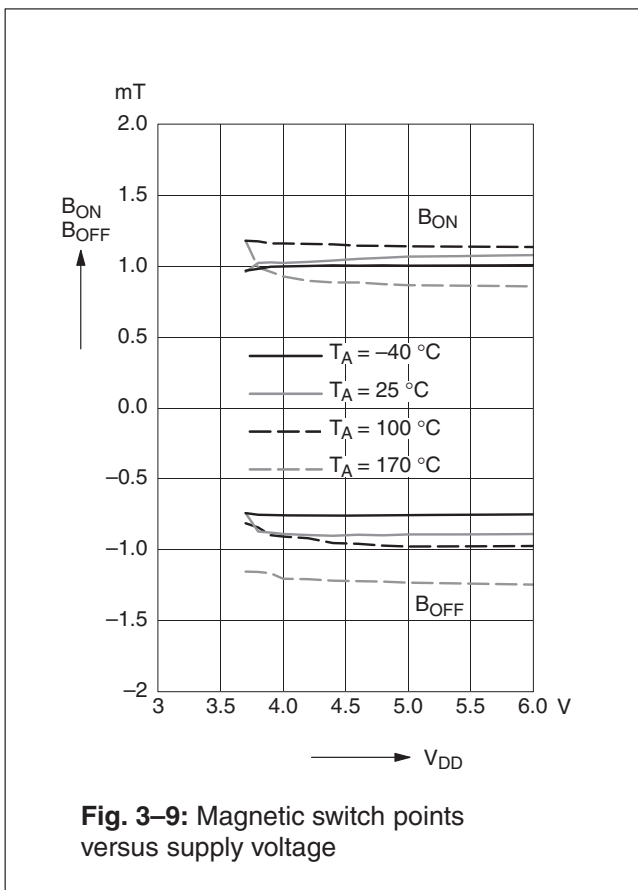
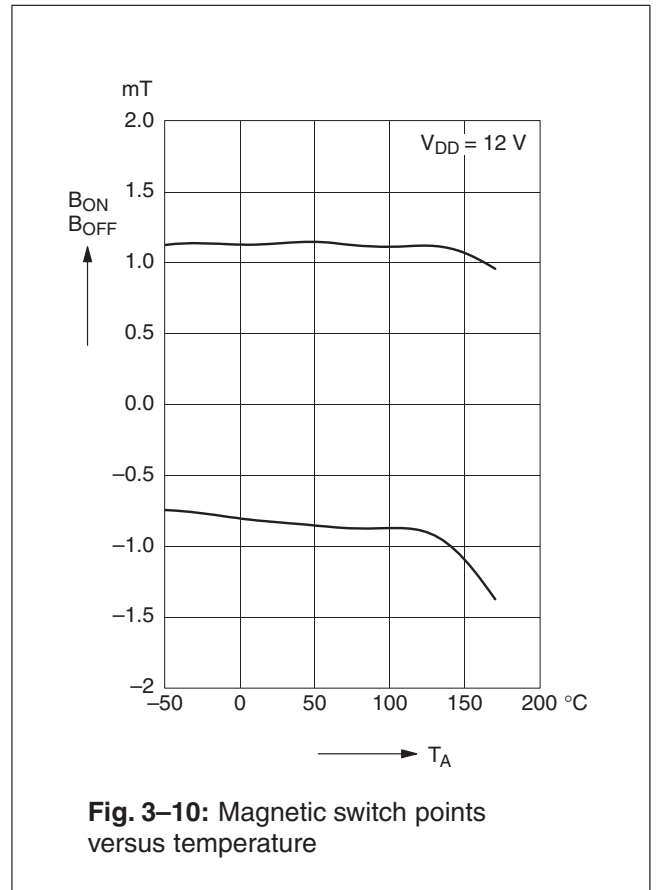
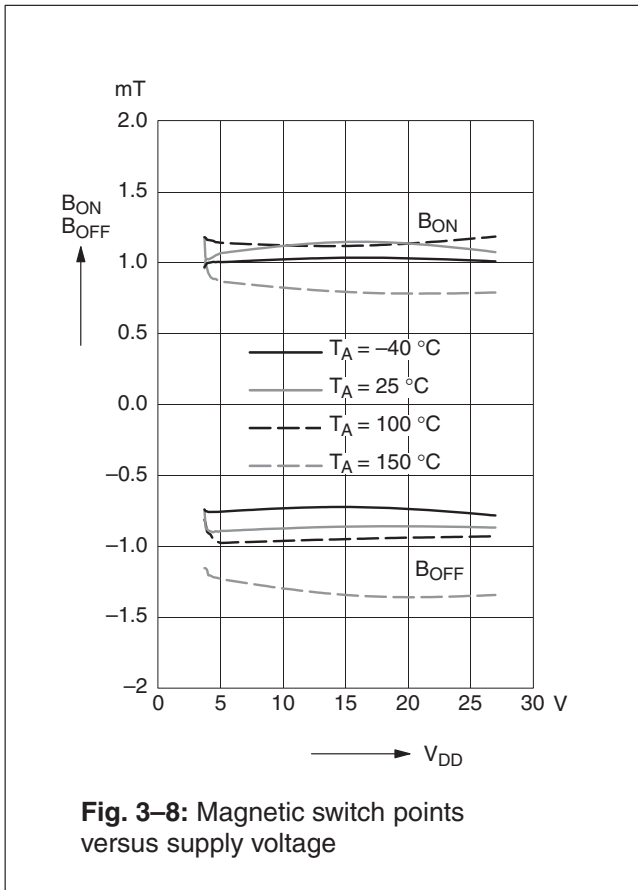
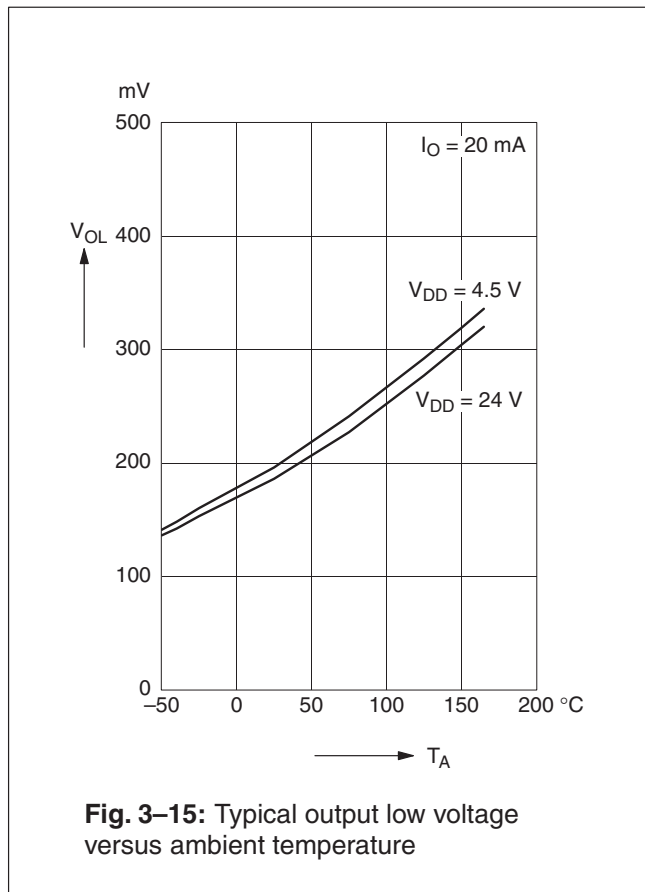
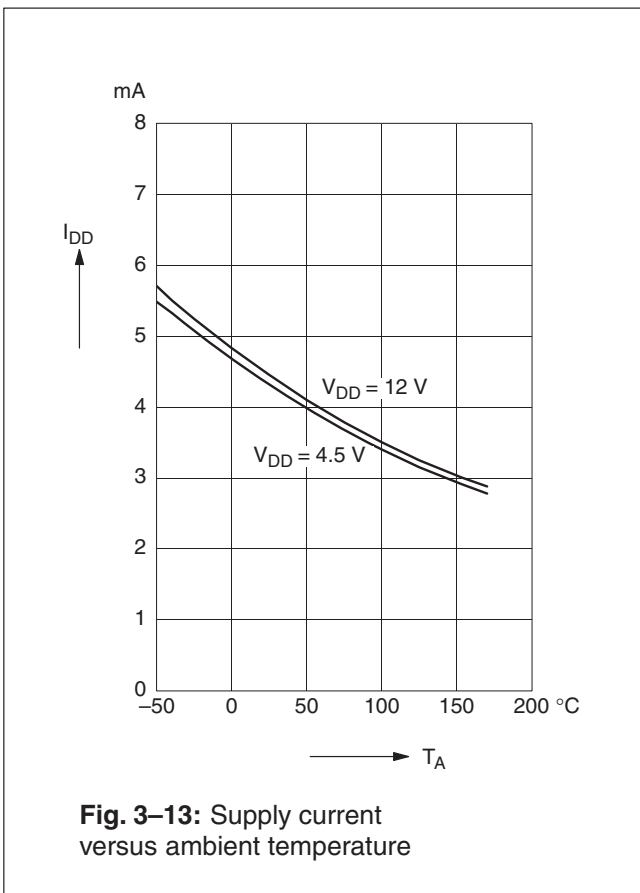
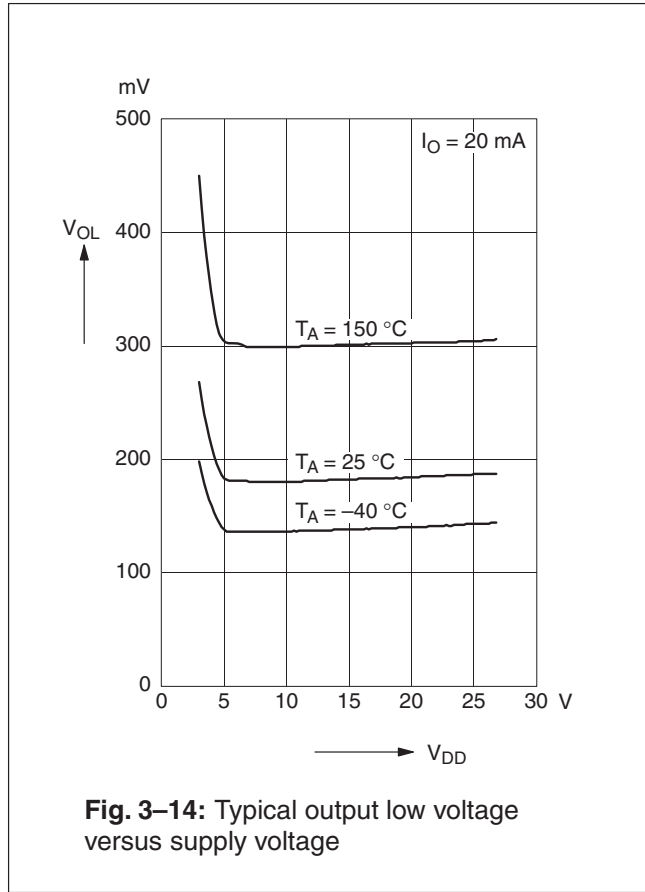
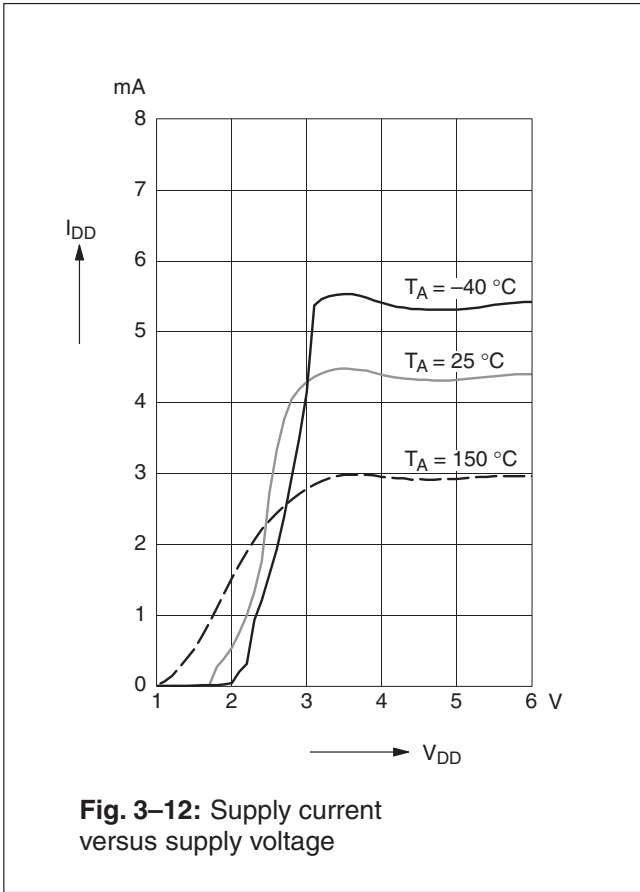

Fig. 3-7: Definition of switching points and hysteresis





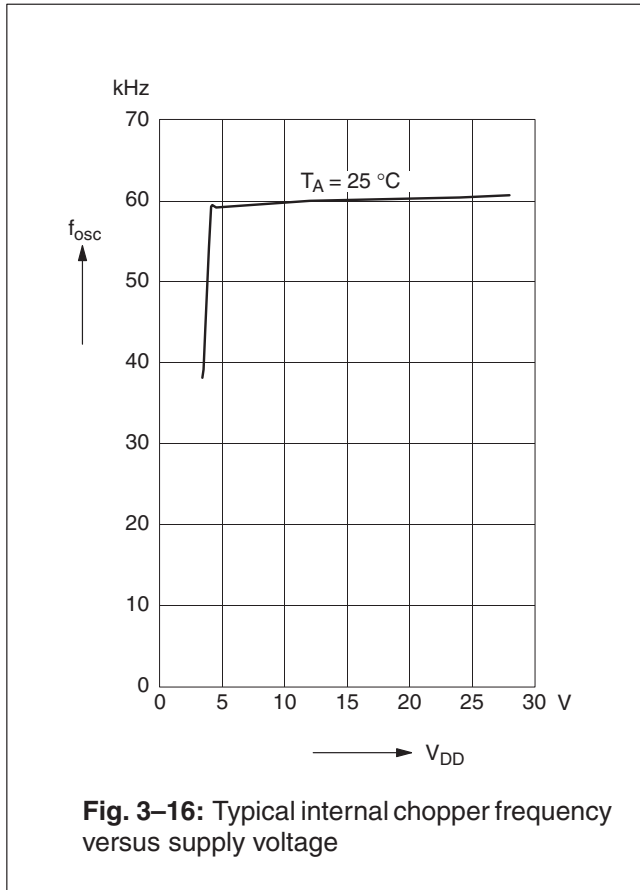

Fig. 3-16: Typical internal chopper frequency versus supply voltage

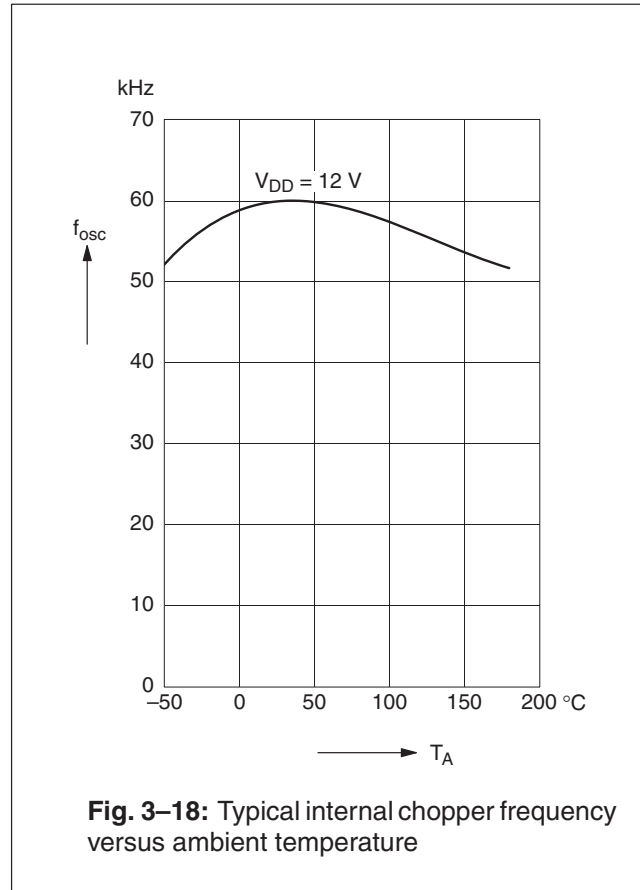

Fig. 3-18: Typical internal chopper frequency versus ambient temperature

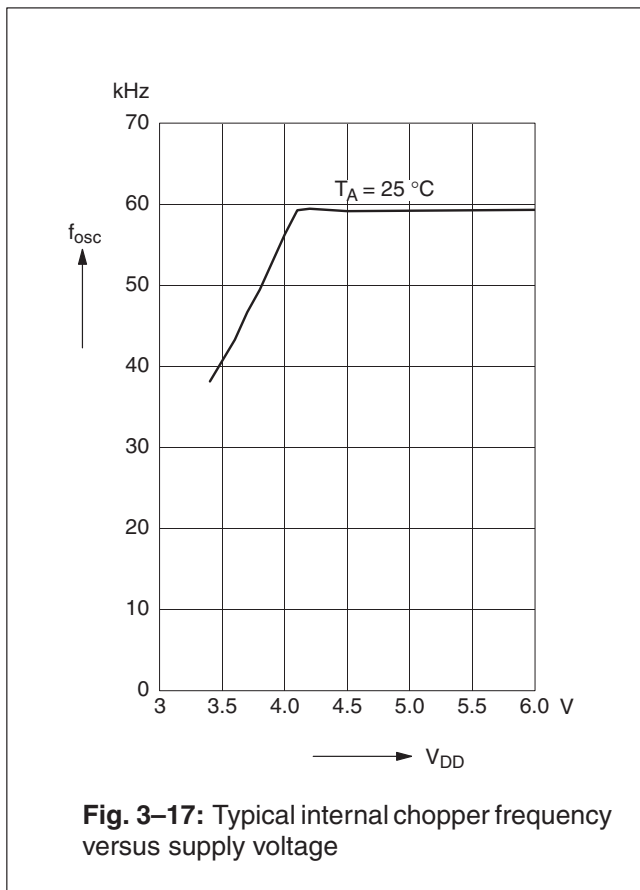

Fig. 3-17: Typical internal chopper frequency versus supply voltage

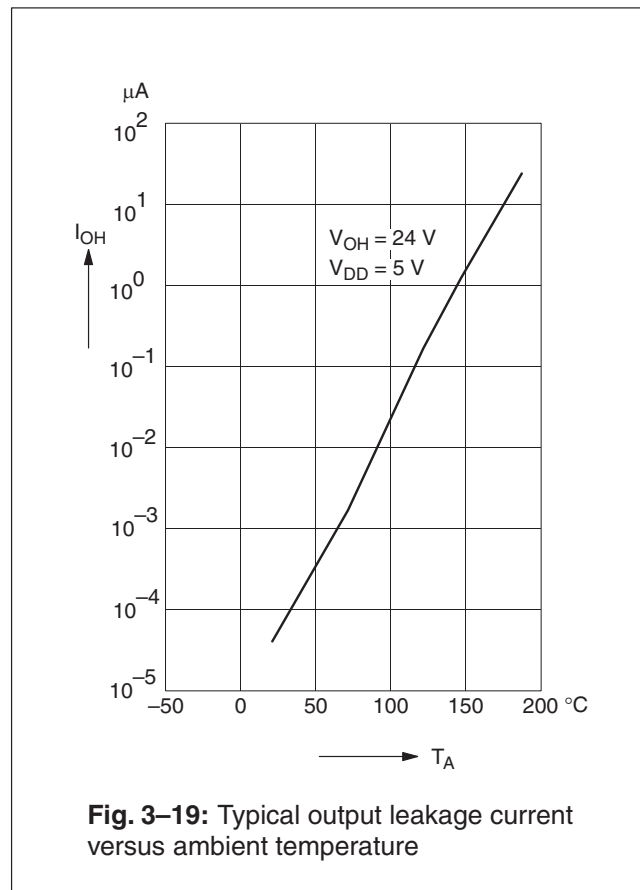
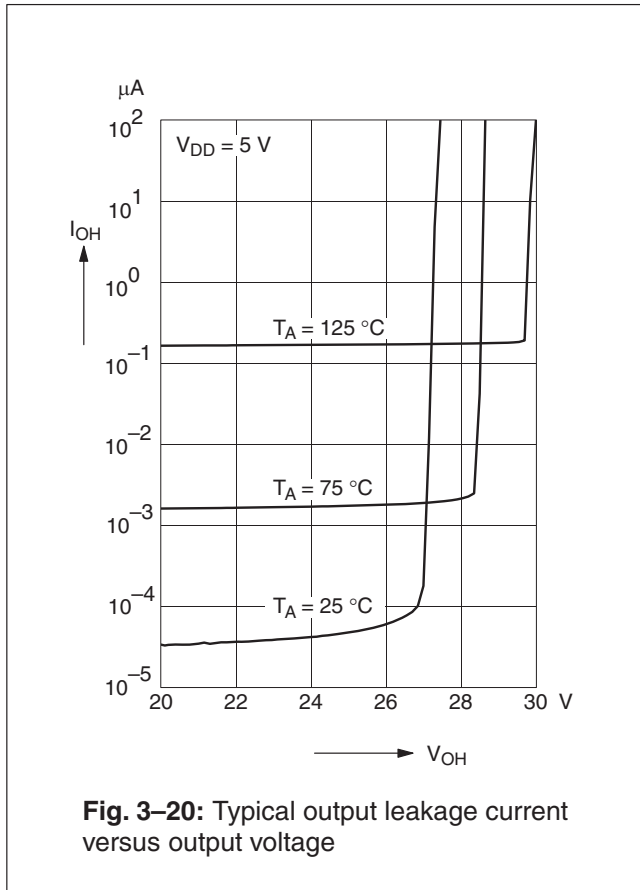

Fig. 3-19: Typical output leakage current versus ambient temperature



4. Application Notes

Mechanical stress can change the sensitivity of the Hall plates and an offset of the magnetic switching points may result. External mechanical stress on the sensor must be avoided if the sensor is used under back-biased conditions. This piezo sensitivity of the sensor IC cannot be completely compensated for by the switching offset compensation technique.

In order to assure switching the sensor on and off in a back-biased application, the minimum magnetic modulation of the differential field should amount to more than 10% of the magnetic preinduction.

If the HAL 320 sensor IC is used in back-biased applications, please contact our Application Department. They will provide assistance in avoiding applications which may induce stress to the ICs. This stress may cause drifts of the magnetic parameters indicated in this data sheet.

4.1. Ambient Temperature

Due to the internal power dissipation, the temperature on the silicon chip (junction temperature T_J) is higher than the temperature outside the package (ambient temperature T_A).

$$T_J = T_A + \Delta T$$

Under static conditions and continuous operation, the following equation applies:

$$\Delta T = I_{DD} * V_{DD} * R_{th}$$

For typical values, use the typical parameters. For worst case calculation, use the max. parameters for I_{DD} and R_{th} , and the max. value for V_{DD} from the application.

For all sensors, the junction temperature range T_J is specified. The maximum ambient temperature T_{Amax} can be calculated as:

$$T_{Amax} = T_{Jmax} - \Delta T$$

4.2. Extended Operating Conditions

All sensors fulfill the electrical and magnetic characteristics when operated within the Recommended Operating Conditions (see page 13).

Supply Voltage Below 4.5 V

Typically, the sensors operate with supply voltages above 3 V, however, below 4.5 V some characteristics may be outside the specification.

Note: The functionality of the sensor below 4.5 V is not tested on regular base. For special test conditions, please contact Micronas.

4.3. Start-up Behavior

Due to the active offset compensation, the sensors have an initialization time (enable time $t_{en(O)}$) after applying the supply voltage. The parameter $t_{en(O)}$ is specified in the Electrical Characteristics (see page 13).

During the initialization time, the output state is not defined and the output can toggle. After $t_{en(O)}$, the output will be low if the applied magnetic field B is above B_{ON} . The output will be high if B is below B_{OFF} .

For magnetic fields between B_{OFF} and B_{ON} , the output state of the HAL sensor after applying V_{DD} will be either low or high. In order to achieve a well-defined output state, the applied magnetic field must be above B_{ONmax} , respectively, below B_{OFFmin} .

4.4. EMC and ESD

For applications with disturbances on the supply line or radiated disturbances, a series resistor and a capacitor are recommended (see Fig. 4–1). The series resistor and the capacitor should be placed as closely as possible to the HAL sensor.

Applications with this arrangement should pass the EMC tests according to the product standard ISO 7637.

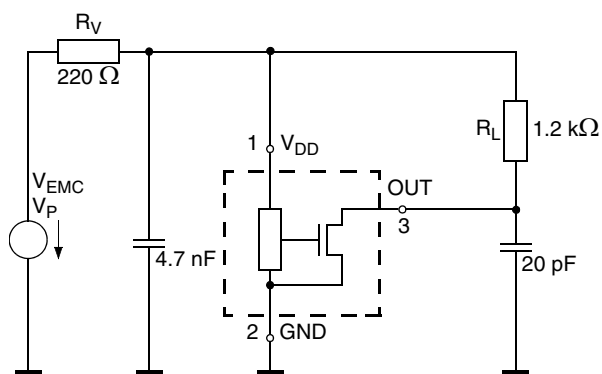

Fig. 4–1: Test circuit for EMC investigations

5. Data Sheet History

1. Final data sheet: "HAL320 Differential Hall Effect Sensor IC", July 15, 1998, 6251-439-1DS. First release of the final data sheet.
2. Final data sheet: "HAL320 Differential Hall Effect Sensor IC", Oct. 19, 2004, 6251-439-2DS. Second release of the final data sheet. Major changes:
 - temperature ranges "C" and "E" removed
 - new package diagrams for SOT89B-2 and TO92UA-4
 - package diagram for TO92UA-3 added
 - ammopack diagrams for TO92UA-3/-4 added
 - new diagram for SOT89B footprint
3. Final data sheet: "HAL320 Differential Hall Effect Sensor IC", Nov. 25, 2008, DSH000017_002. Third release of the final data sheet. Major changes:
 - Section 1.5. "Solderability and Welding" updated
 - package diagrams updated
4. Final data sheet: "Differential Hall-Effect Sensor IC", Jan. 27, 2012, DSH000017_003EN. Fourth release of the final data sheet. Major changes:
 - temperature ranges "I" and "C" added