



Chipsmall Limited consists of a professional team with an average of over 10 year of expertise in the distribution of electronic components. Based in Hongkong, we have already established firm and mutual-benefit business relationships with customers from,Europe,America and south Asia,supplying obsolete and hard-to-find components to meet their specific needs.

With the principle of “Quality Parts,Customers Priority,Honest Operation,and Considerate Service”,our business mainly focus on the distribution of electronic components. Line cards we deal with include Microchip,ALPS,ROHM,Xilinx,Pulse,ON,Everlight and Freescale. Main products comprise IC,Modules,Potentiometer,IC Socket,Relay,Connector.Our parts cover such applications as commercial,industrial, and automotives areas.

We are looking forward to setting up business relationship with you and hope to provide you with the best service and solution. Let us make a better world for our industry!



Contact us

Tel: +86-755-8981 8866 Fax: +86-755-8427 6832

Email & Skype: info@chipsmall.com Web: www.chipsmall.com

Address: A1208, Overseas Decoration Building, #122 Zhenhua RD., Futian, Shenzhen, China



SJ116702
(DRAWING NO.)

版数 VER.	年月日 DATE	CN NO.	変更内容 DESCRIPTION	製図 DR.	担当 CHK.	査閲 APPD.	承認 APPD.
------------	-------------	--------	---------------------	-----------	------------	-------------	-------------

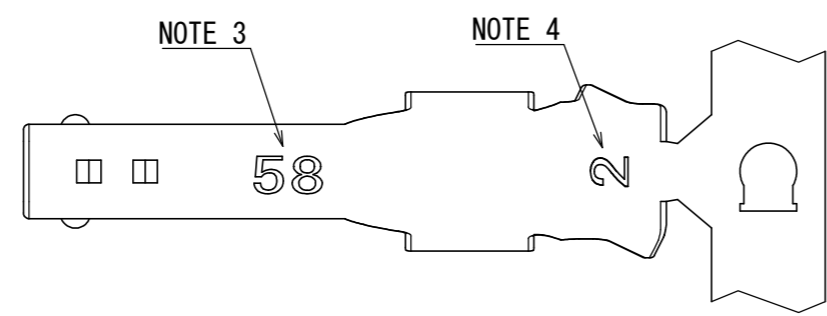
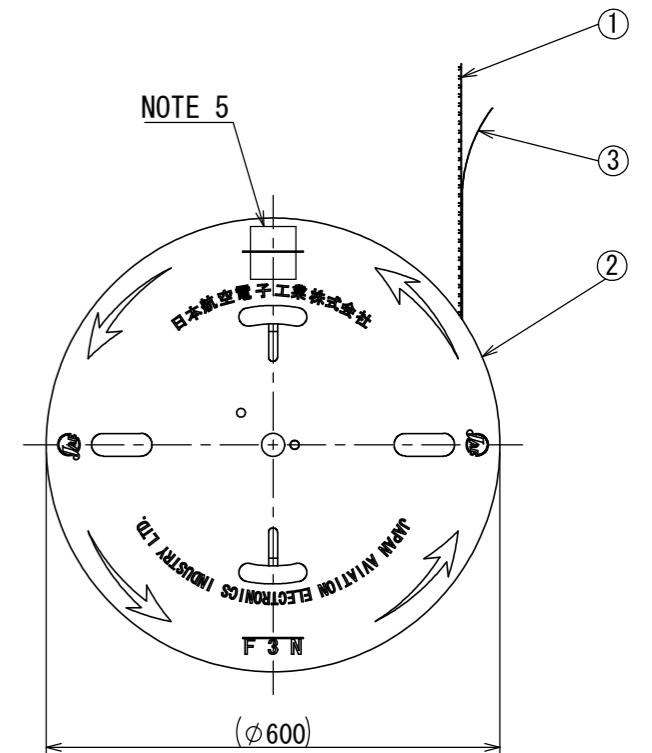
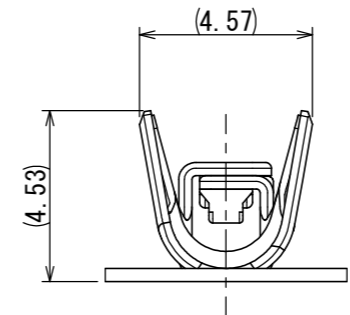
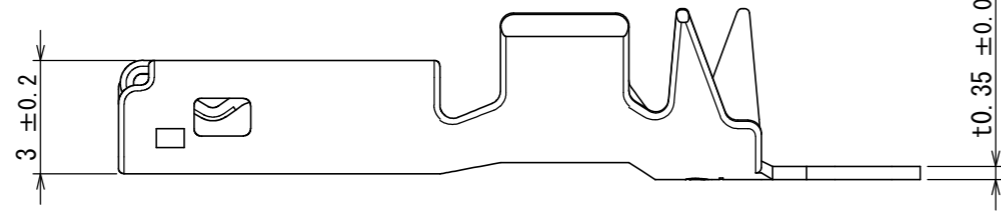
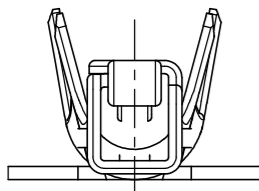
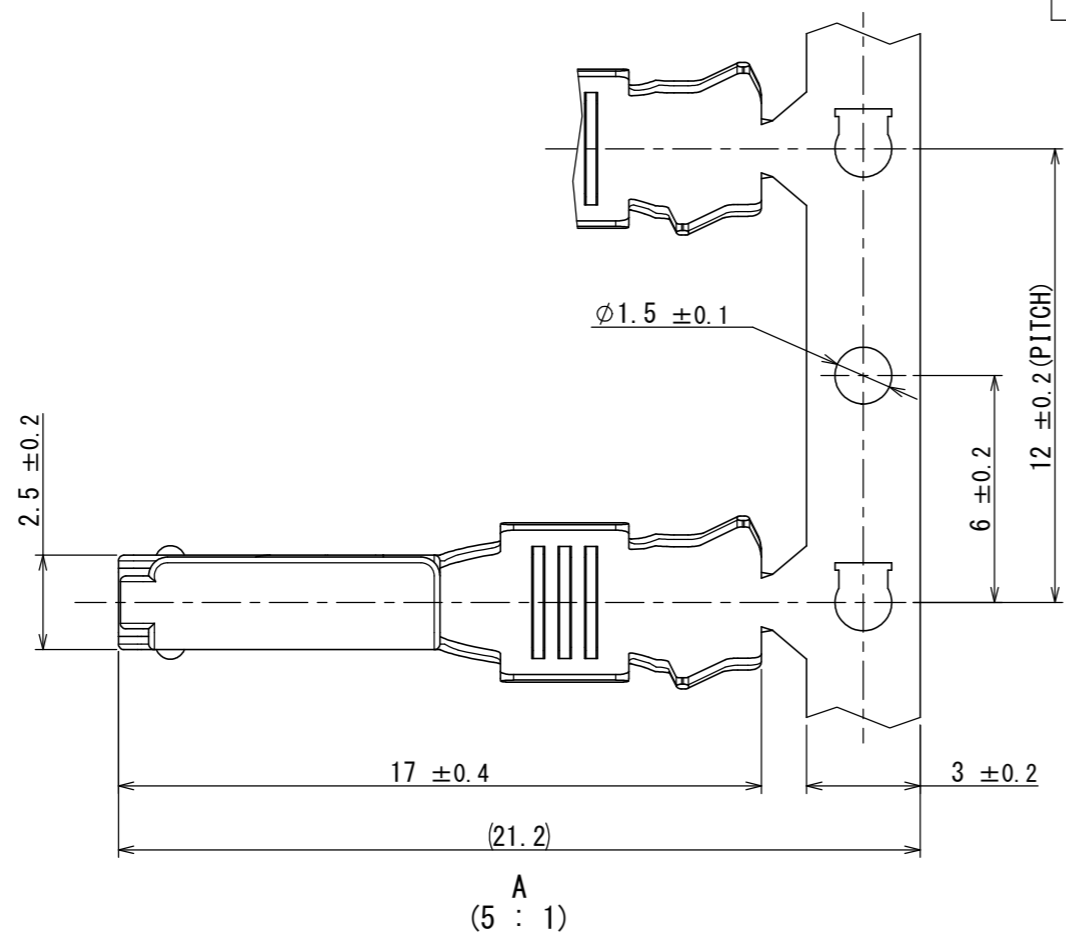

NOTE 1. THESE CONTACTS ARE SUPPLIED IN REEL. THERE ARE 2500 CONTACTS PER REEL.
 NOTE 2. APPLICABLE CABLE: AWG#14 TO #16, INSULATION OUTER DIAMETER: $\phi 2.1\text{mm}$ TO $\phi 2.8\text{mm}$.
 NOTE 3. PRODUCTION DATE IS SHOWN.
 NOTE 4. FORM IDENTIFICATION MARK IS SHOWN.
 NOTE 5. PRODUCT NAME, DRAWING NUMBER AND QUANTITY ARE SHOWN.
 NOTE 6. MATING AREA: GOLD PLATING OVER NICKEL, TERMINAL AREA: TIN PLATING OVER NICKEL
 OTHER AREA: NICKEL PLATING

注1. 本コンタクトは2500個巻きのリールにて供給される。
 注2. 適用電線: AWG#14~#16、被覆外径: $\phi 2.1\sim 2.8\text{mm}$
 注3. 図示の位置に製造年月を表示する。
 注4. 図示の位置に形状識別記号を表示する。
 注5. 図示の位置に品名、図番、数量を表示する。
 注6. 接触部: ニッケル上金めつき、結線部: ニッケル上錫めつき、その他: ニッケルめつき

3	TAPE	1	PAPER	—	—
2	REEL	1	PAPER	—	—
1	SOCKET CONTACT	2500	COPPER ALLOY	NOTE 6	—
符号 NO.	名称 DESCRIPTION	個数 QTY.	材料 MATERIAL	仕上 FINISH	備考 REMARKS

仕様書 (SPECIFICATION) JACS-11114 (-*)		第1版 (ORIGINAL DATE) 04/DEC/2015		尺度 (SCALE) 1:10		シリーズ (SERIES) HB01		日本航空電子工業株式会社	
一般公差 (GENERAL TOLERANCE)		製図 DR.		名称 (TITLE)		HB01S25H2P1		JAE JAPAN AVIATION ELECTRONICS INDUSTRY, LTD.	
寸法 (DIMENSION)		担当 CHK. K. NAKAZAWA		査閲 APPD.		SOCKET CONTACT #14		図面番号 (DRAWING NO.)	
. ± 0.8		角度 (ANGLES)		承認 APPD. T. KUDOU		質量 (MASS)		SJ116702	
. × ± 0.4		×° ±				+		版数 (VER.)	
. ×× ± 0.1		×°×' ±						1	
. ××× ±		単位 (UNIT) : mm							

DCF-C-212H(12.08)

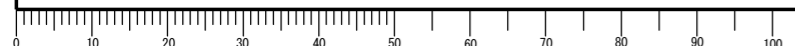

S/W

WISDOM承認 2015/12/08