



Chipsmall Limited consists of a professional team with an average of over 10 year of expertise in the distribution of electronic components. Based in Hongkong, we have already established firm and mutual-benefit business relationships with customers from,Europe,America and south Asia,supplying obsolete and hard-to-find components to meet their specific needs.

With the principle of “Quality Parts,Customers Priority,Honest Operation,and Considerate Service”,our business mainly focus on the distribution of electronic components. Line cards we deal with include Microchip,ALPS,ROHM,Xilinx,Pulse,ON,Everlight and Freescale. Main products comprise IC,Modules,Potentiometer,IC Socket,Relay,Connector.Our parts cover such applications as commercial,industrial, and automotives areas.

We are looking forward to setting up business relationship with you and hope to provide you with the best service and solution. Let us make a better world for our industry!



Contact us

Tel: +86-755-8981 8866 Fax: +86-755-8427 6832

Email & Skype: info@chipsmall.com Web: www.chipsmall.com

Address: A1208, Overseas Decoration Building, #122 Zhenhua RD., Futian, Shenzhen, China



HC-23724-000

SHT 1.1

NOTE:

LOCATED FROM TWO SURFACES FOR CUSTOMER CONVENIENCE. ONLY APPLICABLE FROM ONE SURFACE, NOT TO BE USED TOGETHER. HORIZONTAL LOCATION FOR TERMINAL CENTERED TO ±0,17 [.007]

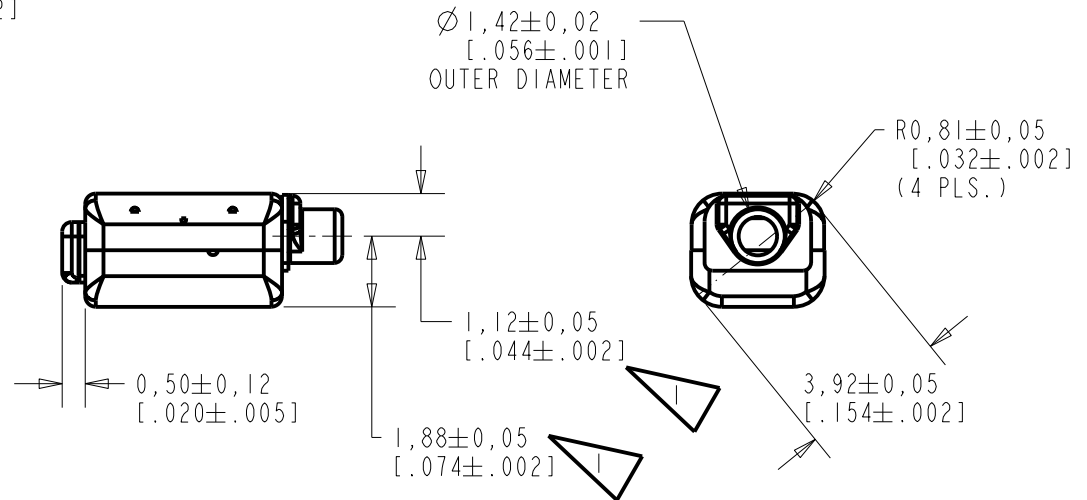
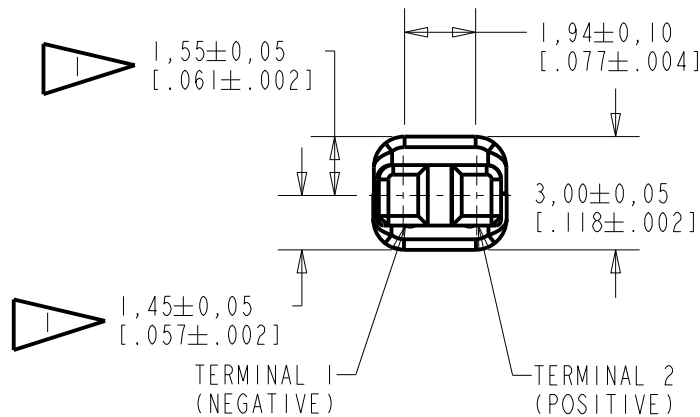
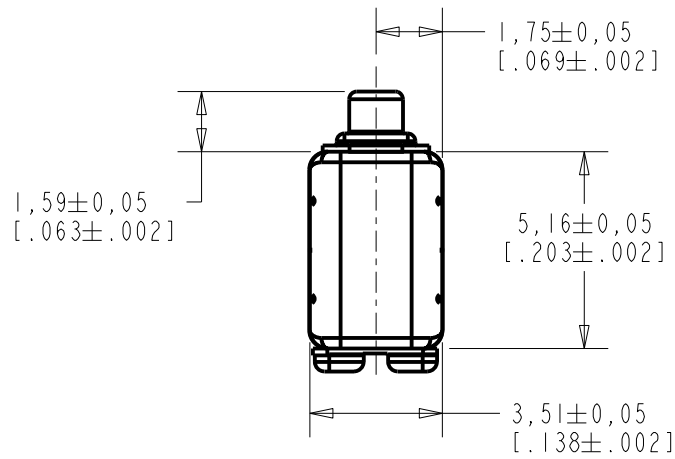

SCALE 2:1

NOMINAL WEIGHT
.23 GRAMS

DIMENSIONS IN MILLIMETERS [INCHES]

KNOWLES ELECTRONICS
ITASCA, ILLINOIS U.S.A.

Revision	C.O. #	Implementation Date	RELEASE LEVEL	REVISION
			Active	D
D	CI0115023P	10-14-13		

SCALE: 5:1		DR. BY: AB	DATE: 11-29-05
DO NOT SCALE DRAWING			
TITLE: RECEIVER		HC-23724-000	
OUTLINE DRAWING		SHT 1.1	
		CK. BY: GJP	DATE: 12-5-05
		APP. BY: GJP	DATE: 12-5-05

DESCRIPTION

NO DAMPING

HC-23724-000

SHEET 2.1

THE HC-23724-000 IS A MAGNETIC BALANCED ARMATURE RECEIVER INTENDED FOR USE IN ITC AND CIC HEARING INSTRUMENTS. THE HC FAMILY OFFERS 6 dB HIGHER OUTPUT LEVELS IN THE SAME SIZE PACKAGE AS THE FC FAMILY. ALL HC UNITS HAVE SHOCK PROTECTION. THIS MODEL HAS MEDIUM-LOW IMPEDANCE AND IS UNDAMPED.

NOTE: SPECIFICATIONS FOLLOWED BY AN ASTERISK (*) ARE 100% TESTED.

CONSTANT VOLTAGE DRIVE RESPONSE

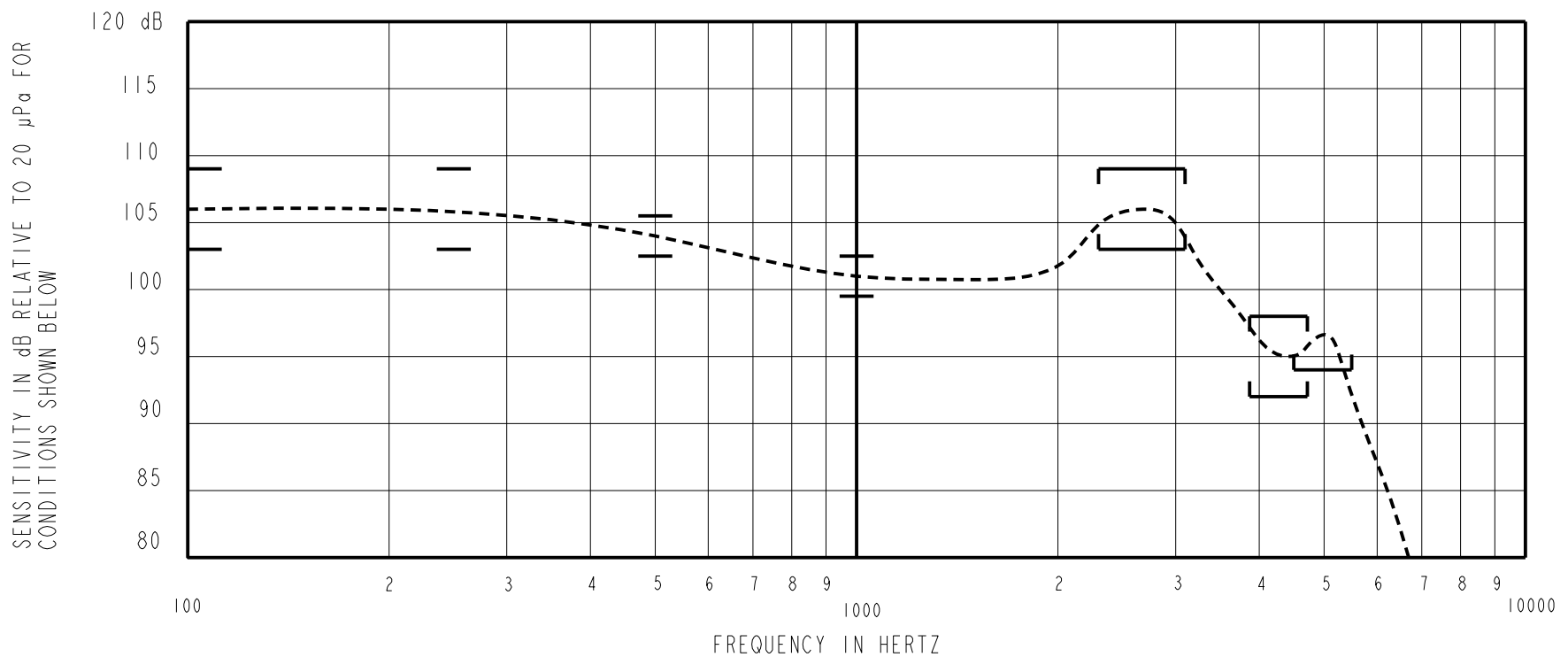

ACOUSTICAL

SENSITIVITY*

DEVICE WILL PRODUCE THE SPL LISTED BELOW WITH THE TEST CONDITIONS DESCRIBED IN TABLE 3. NOMINAL SENSITIVITY AT 1 kHz IS dB RELATIVE TO 20µPa. ALL OTHER VALUES IN dB RELATIVE TO THE SENSITIVITY AT 1 kHz.

FREQUENCY (Hz)	MINIMUM	NOMINAL	MAXIMUM
100	+2.0	+5.0	+8.0
250	+2.0	+5.0	+8.0
500	+1.5	+3.0	+4.5
1000	-1.5	101.0	+1.5
2300-3100 PEAK	+2.0	+5.0	+8.0
3680-4720 VALLEY	-9.0	-6.0	-3.0
4500-5500 PEAK	-7.0	---	---

TABLE 1.

TOTAL HARMONIC DISTORTION*

DEVICE WILL NOT EXCEED TOTAL HARMONIC DISTORTION LEVELS LISTED BELOW.

FREQUENCY (Hz)	DRIVE (Vrms)	DC BIAS (mA)	LIMIT (%)
900	.200 V	0	5
1350	.200 V	0	5
500	.564 V	0	10

TABLE 2.

TEST CONDITIONS

NOMINAL SOURCE VOLTAGE	.200 Vrms, 0 mA DC BIAS
SOURCE IMPEDANCE	< 1 Ω
TUBING	10 mm (.394) LONG, 1 mm (.039) ID.
COUPLER CAVITY	2 CC SIMULATED ANSI S3.7 TYPE HA-3, (IEC 60318-5)

TABLE 3.

POLARITY *

POSITIVE SIGNAL APPLIED TO TERMINAL 2 WILL PRODUCE A DECREASE IN SOUND PRESSURE AT THE SOUND OUTLET.

ELECTRICAL

DC RESISTANCE	63 Ω ±10%	*
IMPEDANCE @ 500 Hz	89 Ω ±15%	*
IMPEDANCE @ 1 kHz	141 Ω ±20%	*
INDUCTANCE @ 500Hz	20 mH ±15%	
CAPACITANCE @ 10 MHz	6 pF ±20%	

TABLE 4.

ISOLATION: THE CASE WILL BE ELECTRICALLY ISOLATED FROM THE COIL CIRCUIT*

MAGNETIC RADIATION

WORST CASE: FIELD WILL BE LESS THAN LEVEL STATED BELOW AT AMPLIFIER CLIPPING (.920 V).

134 dB re 1µA/m

DISTANCE OF 6.3 mm FROM CENTER OF RECEIVER

ANGLE OF 120 DEGREES FROM TUBE

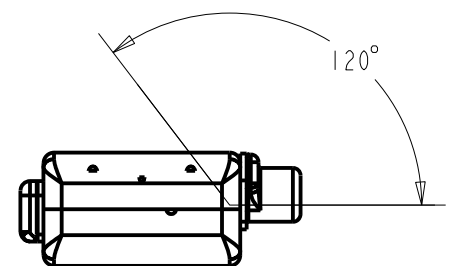

MECHANICAL

PORT LOCATION: 12C

SOLDER TYPE: SAC305

TEMPERATURE

OPERATING: SENSITIVITY WILL NOT VARY MORE THAN +1/-3 dB FROM -17°C TO 63°C

STORAGE: -40°C TO 63°C

RELIABILITY

UNITS WILL SURVIVE ANY OF THE FOLLOWING ACCELERATED LIFE TESTS, REPORT AVAILABLE FROM QA DEPARTMENT

HALT TEST (8 WEEKS, 63°C, 95% RH, 0.83V, 500 Hz SIGNAL)

HIGH TEMPERATURE STORAGE (63°C, 72 HOURS)

LOW TEMPERATURE STORAGE (-40°C, 72 HOURS)

DAMP HEAT CYCLING (ALTERNATE 25°C TO 63°C, 93% RH, 20 CYCLES)

THERMAL SHOCK (-40°C TO 63°C, 5 CYCLES)

SOLDER/DESOLDER CYCLING (5 CYCLES)

SOLDER PAD STRENGTH (STRENGTH > 1.8 LBS.)

STRESS TEST (3.72 Vrms AT 2700 Hz SIGNAL, 1 HOUR)

MECHANICAL SHOCK

LEAK TEST AFTER AGING (NO LEAK AFTER ANY OF THE ABOVE TESTS)

Revision	C.O. #	Implementation Date	RELEASE LEVEL	REVISION
			Active	D
D	C10115023P	10-14-13		
WHEN TEST LIMITS ARE USED TO ESTABLISH INCOMING INSPECTION ACCEPTANCE/REJECTION CRITERIA, CORRELATION OF TEST EQUIPMENT WITH KNOWLES IS ALSO REQUIRED FOR ELIMINATION OF EQUIPMENT AND TEST METHOD VARIATION			DR. BY	DATE
TITLE: RECEIVER PERFORMANCE SPECIFICATION			AB	11-29-05
			HC-23724-000 SHT 2.1	
			CK. BY	DATE
			GJP	12-5-05
			APP. BY	DATE
			GJP	12-5-05

KNOWLES ELECTRONICS
ITASCA, ILLINOIS U.S.A.