



Chipsmall Limited consists of a professional team with an average of over 10 year of expertise in the distribution of electronic components. Based in Hongkong, we have already established firm and mutual-benefit business relationships with customers from,Europe,America and south Asia,supplying obsolete and hard-to-find components to meet their specific needs.

With the principle of “Quality Parts,Customers Priority,Honest Operation,and Considerate Service”,our business mainly focus on the distribution of electronic components. Line cards we deal with include Microchip,ALPS,ROHM,Xilinx,Pulse,ON,Everlight and Freescale. Main products comprise IC,Modules,Potentiometer,IC Socket,Relay,Connector.Our parts cover such applications as commercial,industrial, and automotives areas.

We are looking forward to setting up business relationship with you and hope to provide you with the best service and solution. Let us make a better world for our industry!



## Contact us

Tel: +86-755-8981 8866 Fax: +86-755-8427 6832

Email & Skype: info@chipsmall.com Web: www.chipsmall.com

Address: A1208, Overseas Decoration Building, #122 Zhenhua RD., Futian, Shenzhen, China





# HCF4029B

## PRESETTABLE UP/DOWN COUNTER BINARY OR BCD DECADE

- MEDIUM SPEED OPERATION : 8MHz (Typ.) at  $C_L = 50\text{pF}$  and  $V_{DD} - V_{SS} = 10\text{V}$
- MULTI-PACKAGE PARALLEL CLOCKING FOR SYNCHRONOUS HIGH SPEED OUTPUT RESPONSE OR RIPPLE CLOCKING FOR SLOW CLOCK INPUT RISE AND FALL TIMES
- "PRESET ENABLE" AND INDIVIDUAL "JAM" INPUTS PROVIDED
- BINARY OR DECADE UP/DOWN COUNTING
- BCD OUTPUTS IN DECADE MODE
- QUIESCENT CURRENT SPECIF. UP TO 20V
- STANDARDIZED SYMMETRICAL OUTPUT CHARACTERISTICS
- INPUT LEAKAGE CURRENT  
 $I_l = 100\text{nA}$  (MAX) AT  $V_{DD} = 18\text{V}$   $T_A = 25^\circ\text{C}$
- 100% TESTED FOR QUIESCENT CURRENT
- MEETS ALL REQUIREMENTS OF JEDEC JESD13B "STANDARD SPECIFICATIONS FOR DESCRIPTION OF B SERIES CMOS DEVICES"

### DESCRIPTION

HCF4029B is a monolithic integrated circuit fabricated in Metal Oxide Semiconductor technology available in DIP and SOP packages. HCF4029B consists of a four stage binary or BCD-decade up/down counter with provisions for look ahead carry in both counting modes. The

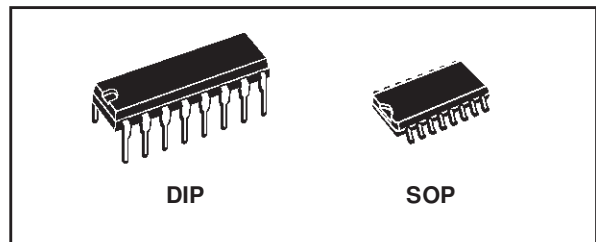

### ORDER CODES

PACKAGE	TUBE	T & R
DIP	HCF4029BEY	
SOP	HCF4029BM1	HCF4029M013TR

inputs consist of a single CLOCK, CARRY IN (CLOCK ENABLE), BINARY/DECADE, UP/DOWN, PRESET ENABLE, and four individual JAM signals. Q<sub>1</sub>, Q<sub>2</sub>, Q<sub>3</sub>, Q<sub>4</sub> and a CARRY OUT signal are provided as outputs. A high PRESET ENABLE signal allows information on the JAM INPUTS to preset the counter to any state asynchronously with the clock. A low on each JAM line, when the PRESET-ENABLE signal is high, resets the counter to its zero count. The counter advances one count at the positive transition of the clock when the CARRY-IN and PRESET ENABLE signals are low. Advancement is inhibited when the CARRY-IN or PRESET ENABLE signals are high. The CARRY-OUT

### PIN CONNECTION

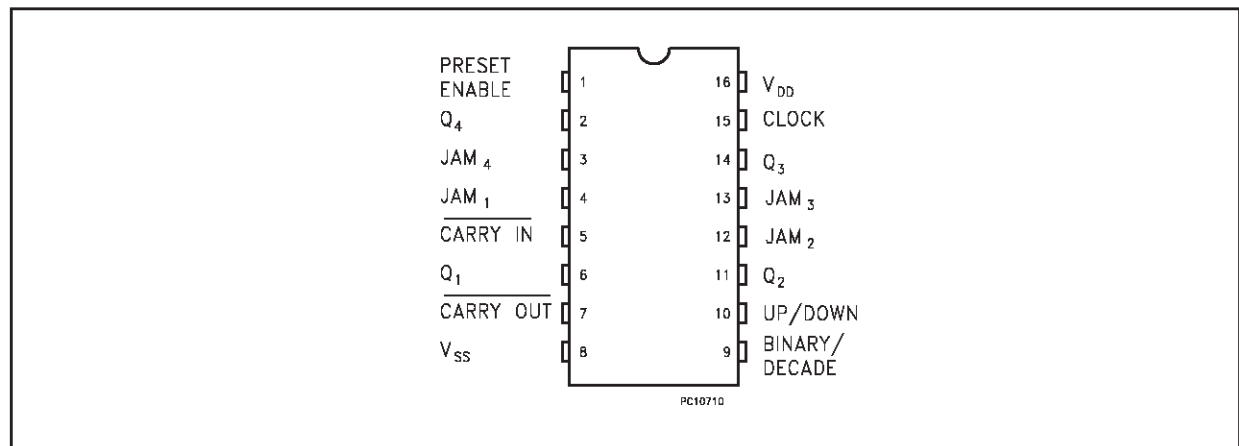

## HCF4029B

signal is normally high and the counter reaches its maximum count in the UP mode or the minimum count in the DOWN mode provided the CARRY-IN signal is low. The CARRY-IN signal in the low state can thus be considered a CLOCK ENABLE. The CARRY-IN terminal must be connected to  $V_{SS}$  when not in use. Binary counting is accomplished when the BINARY/DECODE input is high; the counter counts in the decade mode when the BINARY/DECADE input is low. The

counter counts Up when to UP/DOWN INPUT is high, and Down when the UP/DOWN INPUT is low. Multiple packages can be connected in either a parallel clocking or a ripple clocking arrangement. Parallel clocking provides synchronous control and, hence, a faster response from all counting outputs. Ripple clocking allows for longer clock input rise and fall times.

### INPUT EQUIVALENT CIRCUIT

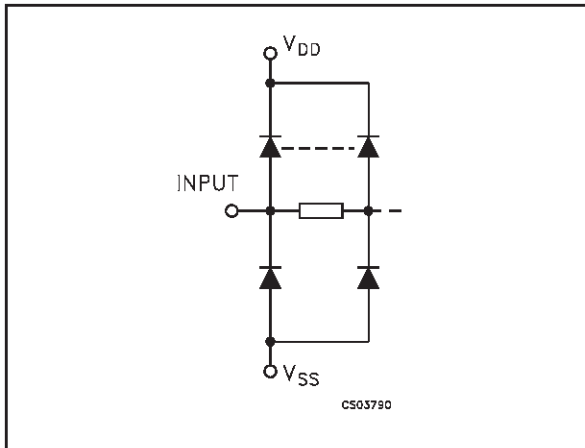



### PIN DESCRIPTION

PIN No	SYMBOL	NAME AND FUNCTION
15	CLOCK	Clock Input
5	CARRY IN	Carry In Input
9	BINARY/DECADE	Binary / Decade Select
10	UP/DOWN	Up/Down Select
1	PRESET ENABLE	Preset Enable Input
4, 12, 13, 3	JAM1 to JAM4	Jam Input Signals
6, 11, 14, 2	Q1 to Q4	Q Outputs
7	CARRY OUT	Carry Out Outputs
8	$V_{SS}$	Negative Supply Voltage
16	$V_{DD}$	Positive Supply Voltage

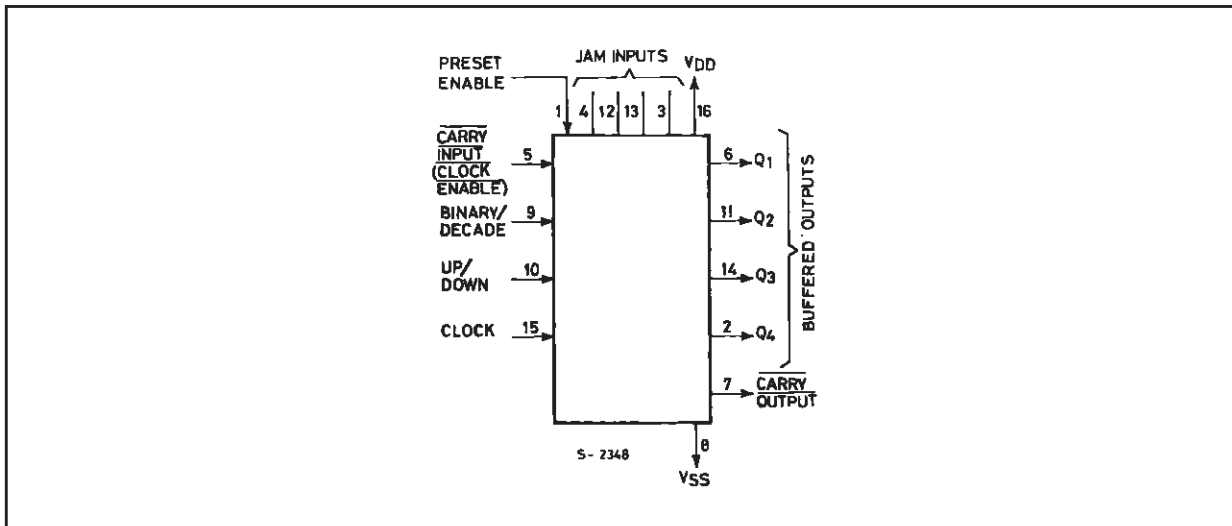
### FUNCTIONAL DIAGRAM



TRUTH TABLE

CLOCK	TE	PE	J	Q	$\bar{Q}$
X	X	L	L	L	H
	L	H	X	$\bar{Q}$	Q
X	X	L	H	H	L
	H	H	X	Q	$\bar{Q}$ NC
	X	H	X	Q	$\bar{Q}$ NC

X: Don't Care

TRUTH TABLE

CONTROL INPUT	LOGIC LEVEL	ACTION
BIN/DEC	H	Binary Count
	L	Decade Count
UP/DOWN	H	Up Count
	L	Down Count
PRESET ENABLE	H	Jam In
	L	No Jam
CARRY IN	H	No Counter
	L	Advance counter

LOGIC DIAGRAM

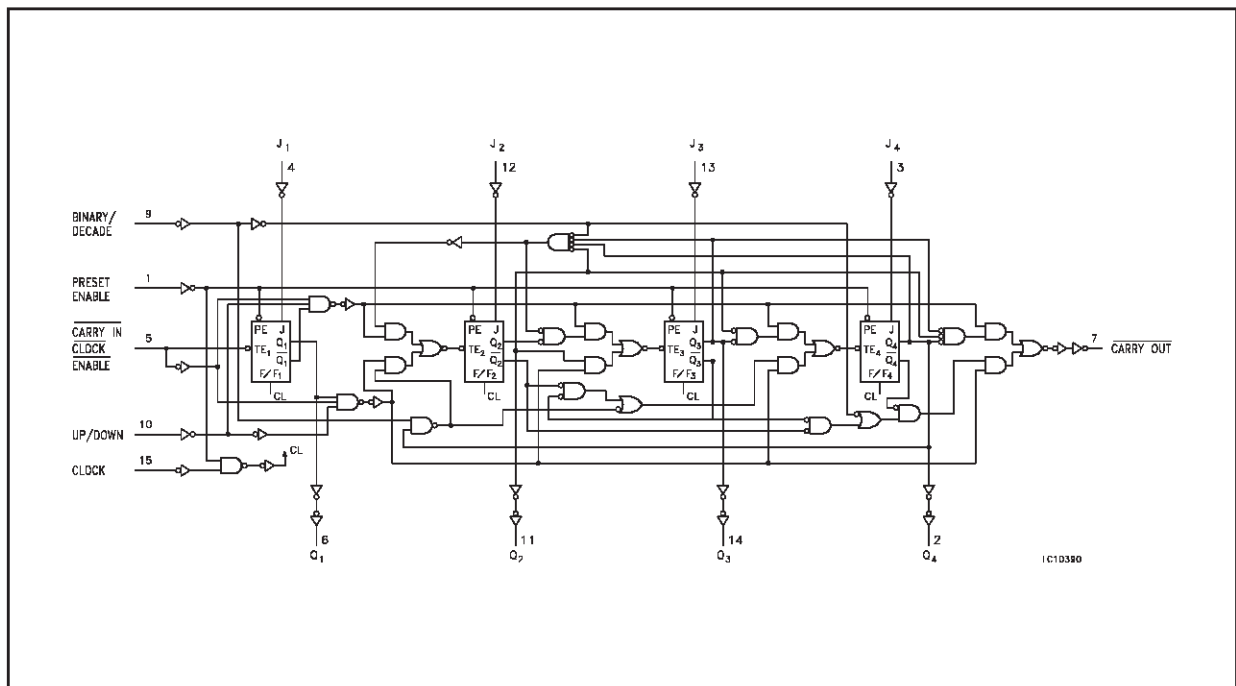



TIMING CHART - Binary Mode

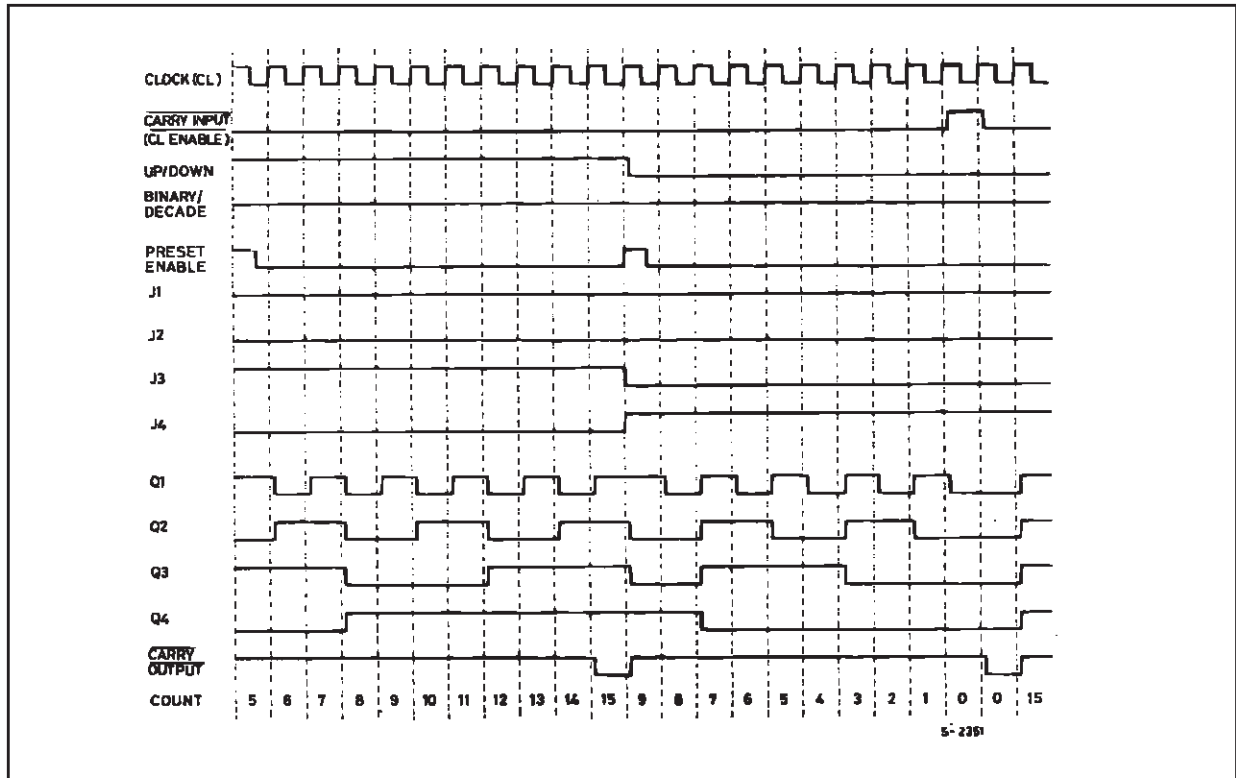

TIMING CHART - Decade Mode

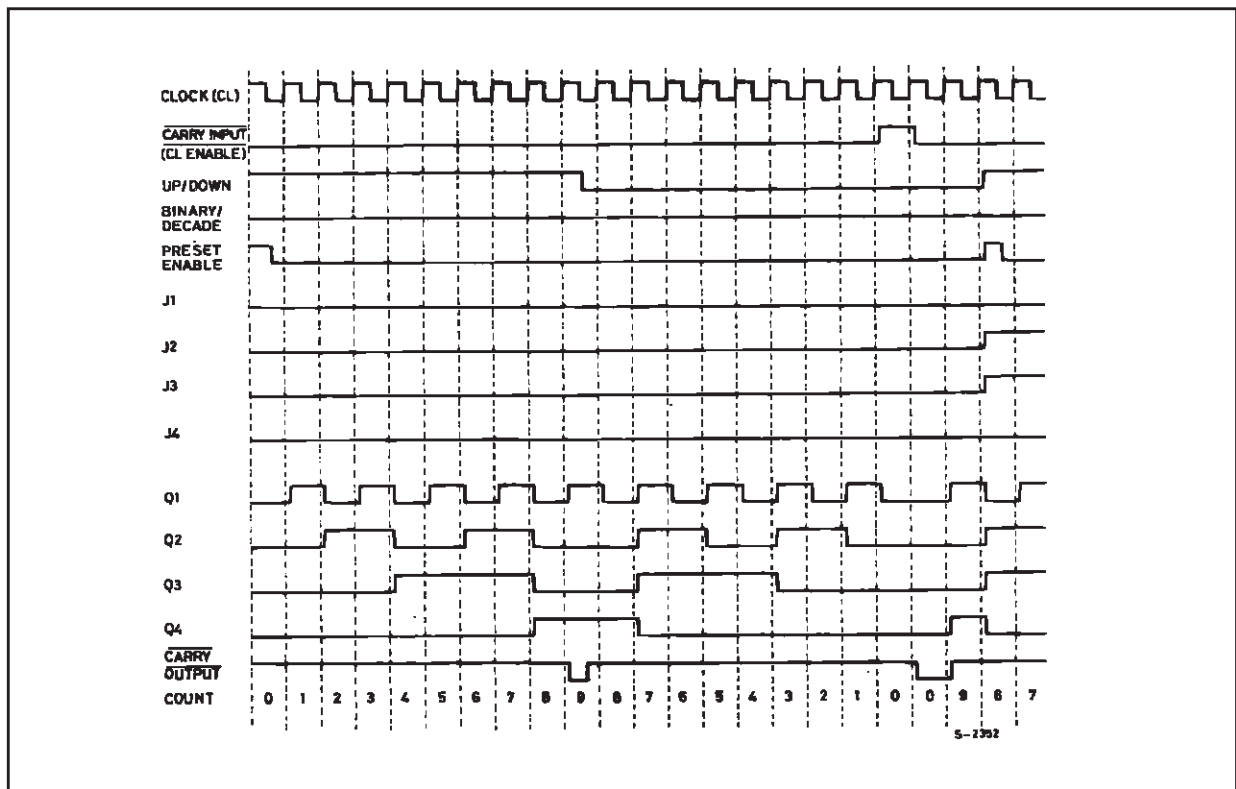

**ABSOLUTE MAXIMUM RATINGS**

Symbol	Parameter	Value	Unit
$V_{DD}$	Supply Voltage	-0.5 to +22	V
$V_I$	DC Input Voltage	-0.5 to $V_{DD} + 0.5$	V
$I_I$	DC Input Current	$\pm 10$	mA
$P_D$	Power Dissipation per Package	200	mW
	Power Dissipation per Output Transistor	100	mW
$T_{op}$	Operating Temperature	-55 to +125	°C
$T_{stg}$	Storage Temperature	-65 to +150	°C

Absolute Maximum Ratings are those values beyond which damage to the device may occur. Functional operation under these conditions is not implied.

All voltage values are referred to  $V_{SS}$  pin voltage.

**RECOMMENDED OPERATING CONDITIONS**

Symbol	Parameter	Value	Unit
$V_{DD}$	Supply Voltage	3 to 20	V
$V_I$	Input Voltage	0 to $V_{DD}$	V
$T_{op}$	Operating Temperature	-55 to 125	°C

## DC SPECIFICATIONS

Symbol	Parameter	Test Conditions				Value						Unit	
		V <sub>I</sub> (V)	V <sub>O</sub> (V)	I <sub>O</sub>   ( $\mu$ A)	V <sub>DD</sub> (V)	T <sub>A</sub> = 25°C			-40 to 85°C		-55 to 125°C		
						Min.	Typ.	Max.	Min.	Max.	Min.		Max.
I <sub>L</sub>	Quiescent Current	0/5			5		0.04	5		150		150	$\mu$ A
		0/10			10		0.04	10		300		300	
		0/15			15		0.04	20		600		600	
		0/20			20		0.08	100		3000		3000	
V <sub>OH</sub>	High Level Output Voltage	0/5		<1	5	4.95			4.95		4.95		V
		0/10		<1	10	9.95			9.95		9.95		
		0/15		<1	15	14.95			14.95		14.95		
V <sub>OL</sub>	Low Level Output Voltage	5/0		<1	5		0.05			0.05		0.05	V
		10/0		<1	10		0.05			0.05		0.05	
		15/0		<1	15		0.05			0.05		0.05	
V <sub>IH</sub>	High Level Input Voltage		0.5/4.5	<1	5	3.5			3.5		3.5		V
			1/9	<1	10	7			7		7		
			1.5/18.5	<1	15	11			11		11		
V <sub>IL</sub>	Low Level Input Voltage		0.5/4.5	<1	5			1.5		1.5		1.5	V
			9/1	<1	10			3		3		3	
			1.5/18.5	<1	15			4		4		4	
I <sub>OH</sub>	Output Drive Current	0/5	2.5		5	-1.36	-3.2		-1.1		-1.1		mA
		0/5	4.6		5	-0.44	-1		-0.36		-0.36		
		0/10	9.5		10	-1.1	-2.6		-0.9		-0.9		
		0/15	13.5		15	-3.0	-6.8		-2.4		-2.4		
I <sub>OL</sub>	Output Sink Current	0/5	0.4		5	0.44	1		0.36		0.36		mA
		0/10	0.5		10	1.1	2.6		0.9		0.9		
		0/15	1.5		15	3.0	6.8		2.4		2.4		
I <sub>I</sub>	Input Leakage Current	0/18	any input		18		$\pm 10^{-5}$	$\pm 0.1$		$\pm 1$		$\pm 1$	$\mu$ A
C <sub>I</sub>	Input Capacitance		any input				5	7.5					pF

The Noise Margin for both "1" and "0" level is: 1V min. with V<sub>DD</sub>=5V, 2V min. with V<sub>DD</sub>=10V, 2.5V min. with V<sub>DD</sub>=15V

**DYNAMIC ELECTRICAL CHARACTERISTICS** ( $T_{amb} = 25^{\circ}\text{C}$ ,  $C_L = 50\text{pF}$ ,  $R_L = 200\text{K}\Omega$ ,  $t_r = t_f = 20\text{ ns}$ )

Symbol	Parameter	Test Condition		Value (*)			Unit
		$V_{DD}$ (V)		Min.	Typ.	Max.	
$t_{PLH}$ $t_{PHL}$	Propagation Delay Time (Q Outputs)	5			250	500	ns
		10			120	240	
		15			90	180	
$t_{PLH}$ $t_{PHL}$	Propagation Delay Time (Carry Output)	5			280	560	ns
		10			130	260	
		15			95	190	
$t_{THL}$ $t_{TLH}$	Transition Time (Q Outputs, Carry Output)	5			100	200	ns
		10			50	100	
		15			40	80	
$t_W$	Minimum Clock Pulse Width	5			90	180	ns
		10			45	90	
		15			30	60	
$t_r, t_f^{(1)}$	Clock Rise and Fall Time	5				15	ns
		10				15	
		15				15	
$t_{setup}^{(2)}$	Minimum Setup Time (Carry Input)	5			30	60	ns
		10			10	20	
		15			6	12	
$t_{setup}$	Minimum Setup Time (B/D or U/D)	5			170	340	ns
		10			70	140	
		15			50	100	
$f_{MAX}$	Maximum Clock Input Frequency	5		2	4		MHz
		10		4	8		
		15		5.5	11		
<b>PRESET ENABLE</b>							
$t_{PLH}$ $t_{PHL}$	Propagation Delay Time (Q Outputs)	5			235	470	ns
		10			100	200	
		15			80	160	
$t_{PLH}$ $t_{PHL}$	Propagation Delay Time (Carry Output)	5			320	640	ns
		10			145	290	
		15			105	210	
$t_W$	Minimum Preset Enable (Pulse Width)	5			65	130	ns
		10			35	70	
		15			25	50	
$t_{rem}^{(2)}$	Minimum Preset Enable (Removal Time)	5			100	200	ns
		10			55	110	
		15			40	80	



## HCF4029B

Symbol	Parameter	Test Condition		Value (*)			Unit
		V <sub>DD</sub> (V)		Min.	Typ.	Max.	
<b>PRESET ENABLE</b>							
t <sub>PHL</sub> t <sub>PLH</sub>	Propagation Delay Time (Carry Output)	5			170	340	ns
		10			70	140	
		15			50	100	
t <sub>setup</sub> <sup>(3)</sup>	Minimum Setup Time (Carry In)	5			25	50	ns
		10			15	30	
		15			12	25	
t <sub>hold</sub>	Minimum Hold Time (Carry In)	5			100	200	ns
		10			35	70	
		15			30	60	

(\*) Typical temperature coefficient for all V<sub>DD</sub> value is 0.3 %/°C.

(1) If more than one unit is cascaded in the parallel clocked application t<sub>r</sub> should be made less than or equal to the sum of the fixed propagation delay at 15pF and the transition time of the carry output driving stage for the estimated capacitance load.

(2) From Up/Down, Binary/Decade, Carry In or Preset Enable Control Inputs to Clock Edge.

(3) From Carry In to Clock Edge.

### TEST CIRCUIT

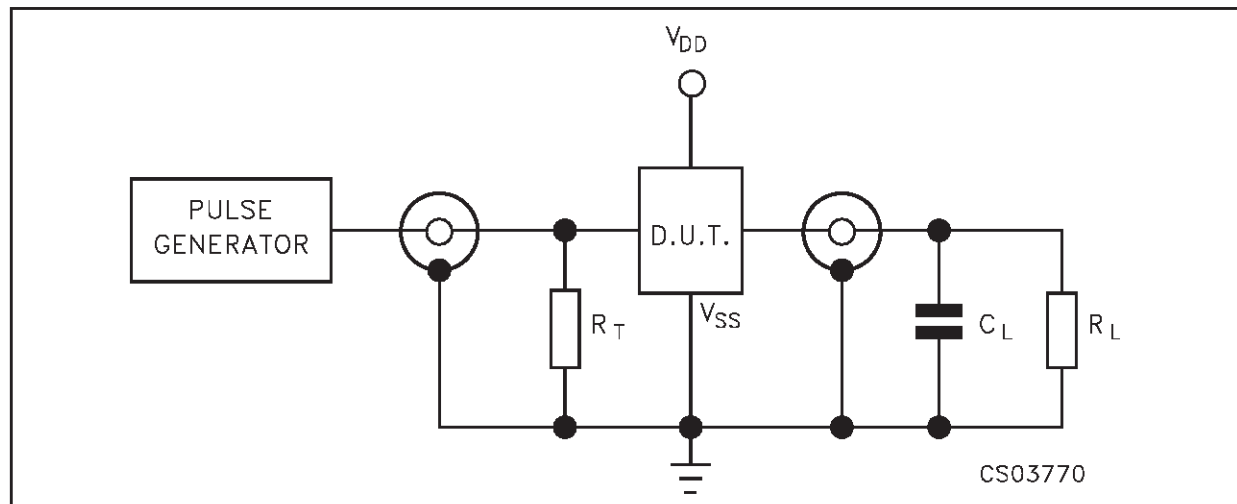

C<sub>L</sub> = 50pF or equivalent (includes jig and probe capacitance)

R<sub>L</sub> = 200KΩ

R<sub>T</sub> = Z<sub>OUT</sub> of pulse generator (typically 50Ω)

WAVEFORM 1 : PROPAGATION DELAY TIMES (f=1MHz; 50% duty cycle)

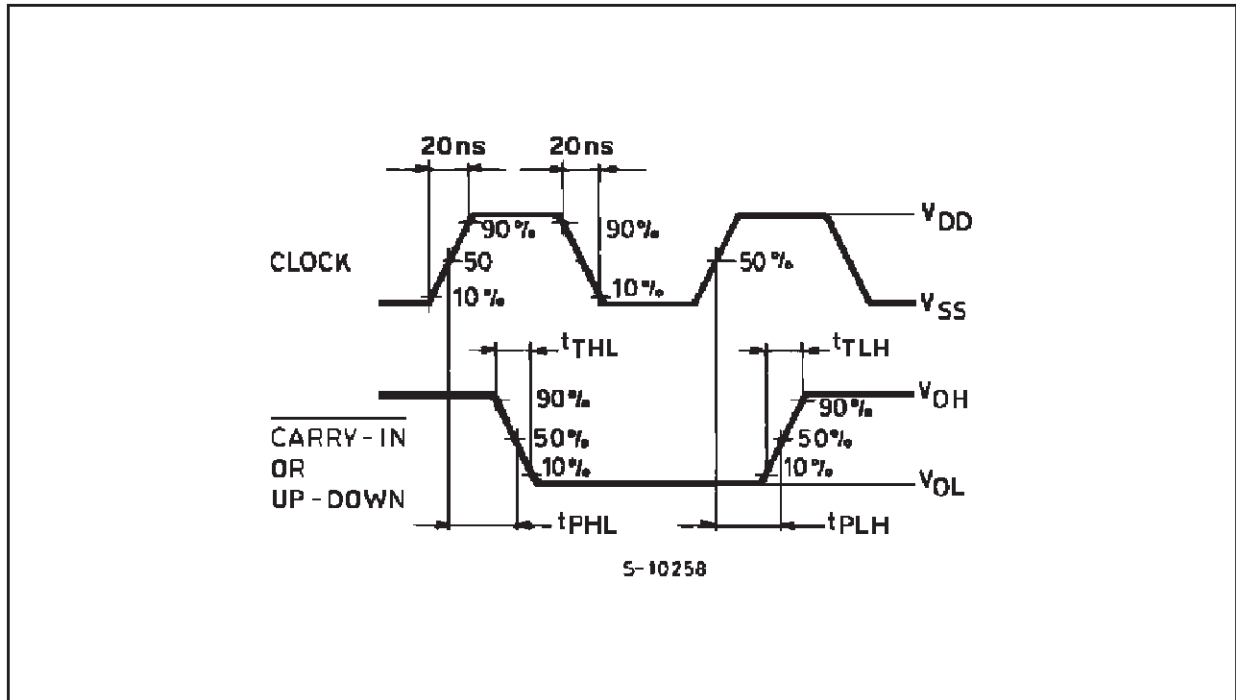

WAVEFORM 2 : PROPAGATION DELAY TIMES (f=1MHz; 50% duty cycle)

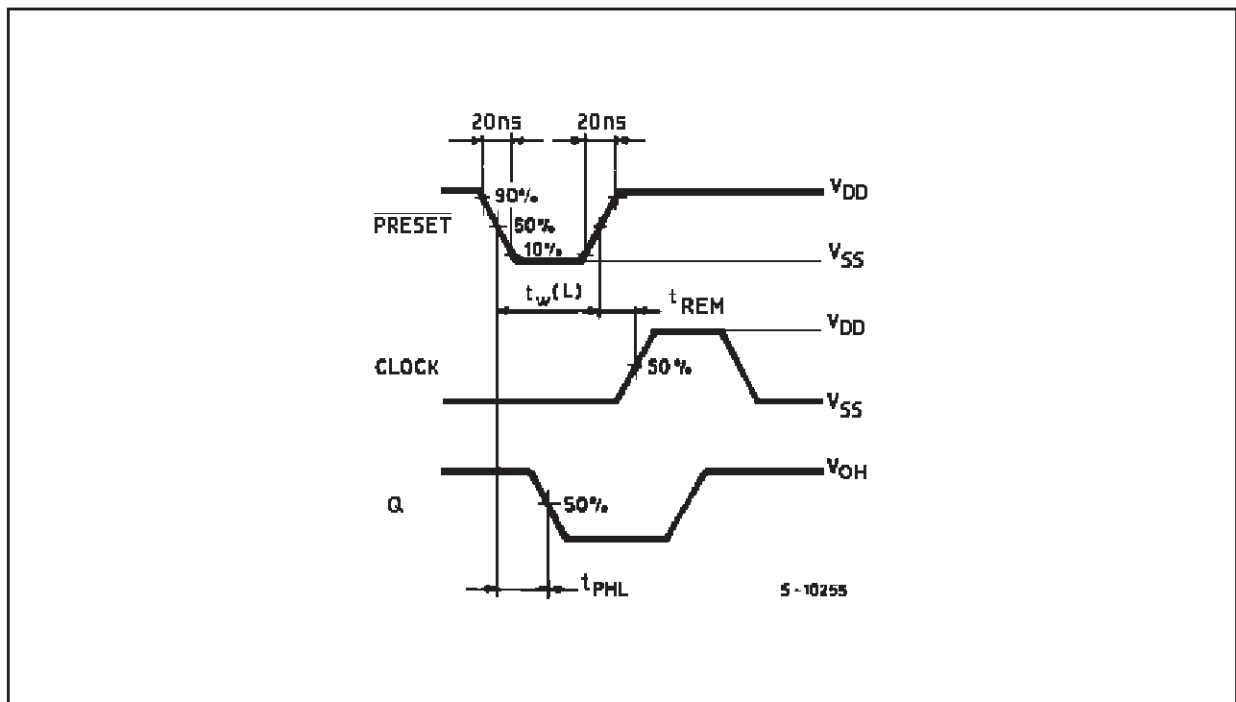

### Plastic DIP-16 (0.25) MECHANICAL DATA

DIM.	mm.			inch		
	MIN.	TYP	MAX.	MIN.	TYP.	MAX.
a1	0.51			0.020		
B	0.77		1.65	0.030		0.065
b		0.5			0.020	
b1		0.25			0.010	
D			20			0.787
E		8.5			0.335	
e		2.54			0.100	
e3		17.78			0.700	
F			7.1			0.280
I			5.1			0.201
L		3.3			0.130	
Z			1.27			0.050

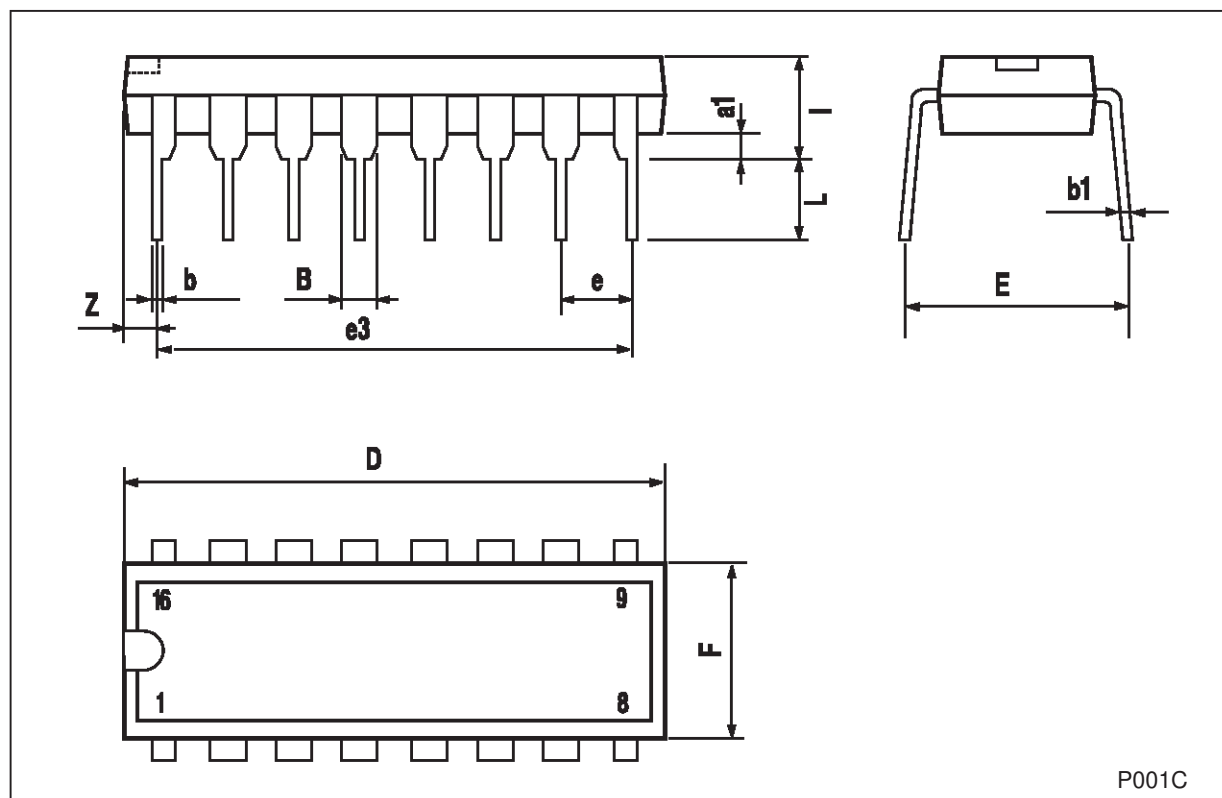

P001C

## SO-16 MECHANICAL DATA

DIM.	mm.			inch		
	MIN.	TYP.	MAX.	MIN.	TYP.	MAX.
A			1.75			0.068
a1	0.1		0.2	0.003		0.007
a2			1.65			0.064
b	0.35		0.46	0.013		0.018
b1	0.19		0.25	0.007		0.010
C		0.5			0.019	
c1	45° (typ.)					
D	9.8		10	0.385		0.393
E	5.8		6.2	0.228		0.244
e		1.27			0.050	
e3		8.89			0.350	
F	3.8		4.0	0.149		0.157
G	4.6		5.3	0.181		0.208
L	0.5		1.27	0.019		0.050
M			0.62			0.024
S	8° (max.)					

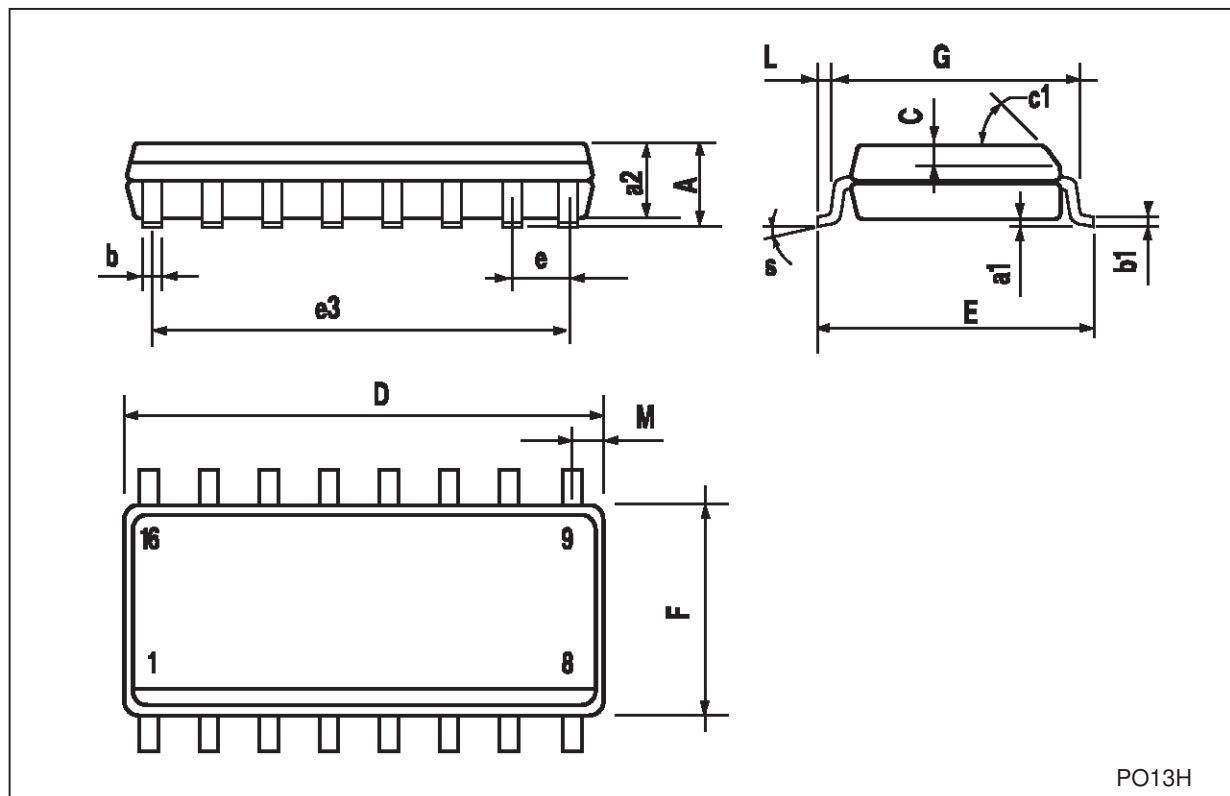

PO13H

Information furnished is believed to be accurate and reliable. However, STMicroelectronics assumes no responsibility for the consequences of use of such information nor for any infringement of patents or other rights of third parties which may result from its use. No license is granted by implication or otherwise under any patent or patent rights of STMicroelectronics. Specifications mentioned in this publication are subject to change without notice. This publication supersedes and replaces all information previously supplied. STMicroelectronics products are not authorized for use as critical components in life support devices or systems without express written approval of STMicroelectronics.

© The ST logo is a registered trademark of STMicroelectronics

© 2002 STMicroelectronics - Printed in Italy - All Rights Reserved  
STMicroelectronics GROUP OF COMPANIES

Australia - Brazil - Canada - China - Finland - France - Germany - Hong Kong - India - Israel - Italy - Japan - Malaysia - Malta - Morocco  
Singapore - Spain - Sweden - Switzerland - United Kingdom - United States.

© <http://www.st.com>