



Chipsmall Limited consists of a professional team with an average of over 10 year of expertise in the distribution of electronic components. Based in Hongkong, we have already established firm and mutual-benefit business relationships with customers from,Europe,America and south Asia,supplying obsolete and hard-to-find components to meet their specific needs.

With the principle of “Quality Parts,Customers Priority,Honest Operation,and Considerate Service”,our business mainly focus on the distribution of electronic components. Line cards we deal with include Microchip,ALPS,ROHM,Xilinx,Pulse,ON,Everlight and Freescale. Main products comprise IC,Modules,Potentiometer,IC Socket,Relay,Connector.Our parts cover such applications as commercial,industrial, and automotives areas.

We are looking forward to setting up business relationship with you and hope to provide you with the best service and solution. Let us make a better world for our industry!



Contact us

Tel: +86-755-8981 8866 Fax: +86-755-8427 6832

Email & Skype: info@chipsmall.com Web: www.chipsmall.com

Address: A1208, Overseas Decoration Building, #122 Zhenhua RD., Futian, Shenzhen, China



DO NOT SCALE FROM THIS PRINT

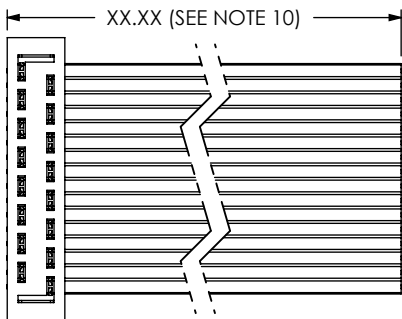
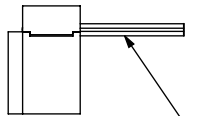

FIG 2
HCSD-08-S-XX.XX-01 SHOWN
(DIFFERENT AS SHOWN, OTHERWISE SAME AS FIG 1)



CB-XX-28-7/36-050-G

FIG 3
-G: GRAY CABLE
(DIFFERENT AS SHOWN, OTHERWISE SAME AS FIG 1)

HCSD-XX-X-XX.XX-01-XXX-XXX

NO OF POSITIONS
-02 THRU -36
(STANDARD COLOR CODED CABLE)
(-32 & -36 ONLY AVAILABLE WITH -G OPTION)

OPTION #2
(SEE FIG 3 THRU FIG 19 FOR AVAILABLE OPTIONS)
OPTION #1
(SEE FIG 3 THRU FIG 19 FOR AVAILABLE OPTIONS)

END ASSEMBLY
-S: SINGLE END
-D: DOUBLE END

ASSEMBLY LENGTH
(2 INCH MINIMUM)

-T: BRIGHT ACID TIN ON ENTIRE PIN
(USE HCSD-XX-01-TX)
LEAVE BLANK FOR 10μ" SELECTIVE GOLD IN CONTACT AREA, BRIGHT ACID TIN ON TAIL.

FIG 4
-T: TIN PLATING

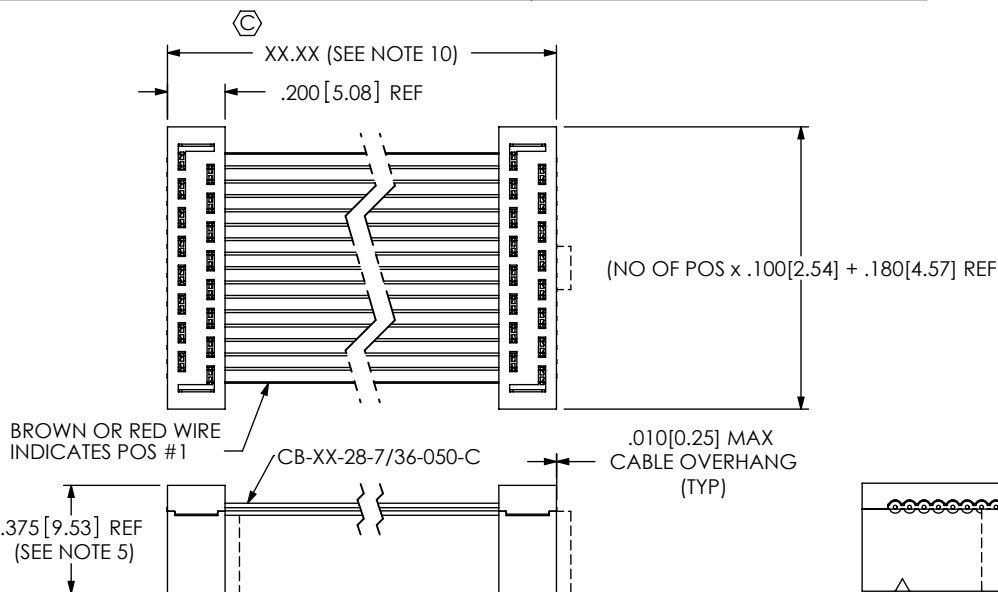

FIG 1
HCSD-08-D-XX.XX-01 SHOWN

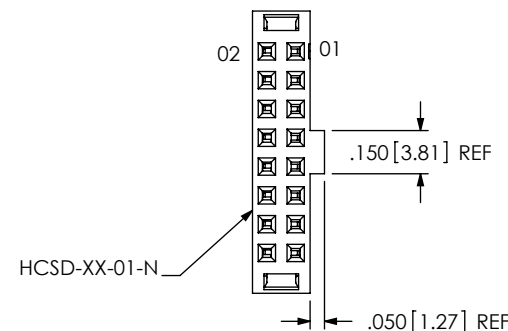

FIG 5
-N: NOTCH
(NOT AVAILABLE ON -02 POSITION)
(DIFFERENT AS SHOWN, OTHERWISE SAME AS FIG 1)

F:\DWG\MISC\MKTG\HCSD-XX-X-XX.XX-01-XXX-XXX-MKT.SLDDRW

NOTES:

1. Ⓢ REPRESENTS A CRITICAL DIMENSION.
2. HIDDEN LINES ARE USED TO SHOW POLARIZATION WHEN USING -N OPTION.
3. ALL ASSEMBLIES TO BE 100% ELECTRICALLY TESTED FOR SHORTS AND OPENS
4. ALL ASSEMBLIES TO BE 100% HI-POT TESTED AT 1000V.
5. HCSD-XX-01-X TO BE PRESSED TOGETHER WITH NO GAPS BETWEEN CABLE & BODIES.
6. CONDUCTORS SHALL BE CONSISTENT IN APPEARANCE, SOLDER MUST MAINTAIN CABLE STRANDS WITHIN THE MAX DIA. TOLERANCE.
7. NOTE DELETED.
8. FOR R OR RW OPTION, CABLE RIB ORIENTATION CAN BE EITHER TOWARDS OR AWAY FROM THE CAP.
9. WHEN CUTTING CABLE TO LENGTH, CONDUCTORS SHOULD NOT EXTEND PAST THE CABLE INSULATION, EXTENDING LESS THAN 25% OF CABLE THICKNESS ON CONSECUTIVE AND LESS THAN 50% OF THE CABLE THICKNESS ON NON-CONSECUTIVE STRANDS IS CONSIDERED A PROCESS INDICATOR.
10. FOR LENGTHS LESS THAN 12.5", TOLERANCE SHALL BE ±.125[3.18], ALL OTHER LENGTHS SHALL BE ±1%.

UNLESS OTHERWISE SPECIFIED, DIMENSIONS ARE IN INCHES.
TOLERANCES ARE:
DECIMALS ANGLES
.XX: ±.01 [.3] 1°
.XXX: ±.005 [.13]
.XXXX: ±.0020 [.051]

PROPRIETARY NOTE
THIS DOCUMENT CONTAINS CONFIDENTIAL AND PROPRIETARY INFORMATION AND ALL DESIGN, MANUFACTURING, REPRODUCTION, USE, PATENT RIGHTS AND SALES RIGHTS ARE EXPRESSLY RESERVED BY SAMTEC, INC. THIS DOCUMENT SHALL NOT BE DISCLOSED, IN WHOLE OR PART, TO ANY UNAUTHORIZED PERSON OR ENTITY NOR REPRODUCED, TRANSFERRED OR INCORPORATED IN ANY OTHER PROJECT IN ANY MANNER WITHOUT THE EXPRESS WRITTEN CONSENT OF SAMTEC, INC.

MATERIAL: DO NOT SCALE DRAWING SHEET SCALE: 3:2
INSULATOR: LCP, UL 94 VO, COLOR: BLACK
CONTACT: PHOS BRONZE
CABLE: COLOR-CODED OR GRAY PVC/TIN PLATED COPPER

samtec
520 PARK EAST BLVD. NEW ALBANY, IN 47150
PHONE: 812-944-6733 FAX: 812-948-5047
e-Mail: info@SAMTEC.com code 55322

DESCRIPTION: .100 CL MOLD TO POS DOUBLE ROW FEMALE ASSEMBLY

DWG. NO. HCSD-XX-X-XX.XX-01-XXX-XXX

BY: KOLB 08/03/1990 SHEET 1 OF 4

REVISION AB

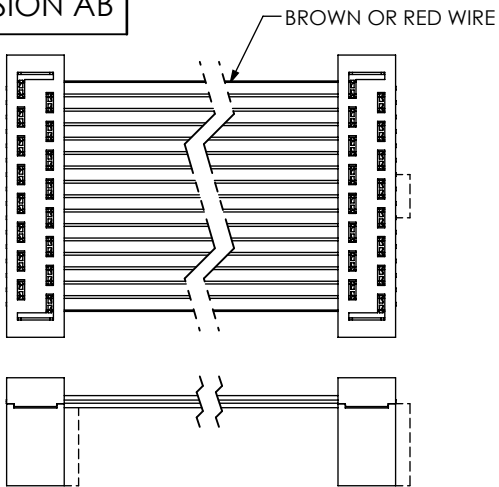

FIG 6

-RW: REVERSE WIRING
(DIFFERENT AS SHOWN, OTHERWISE SAME AS FIG1)

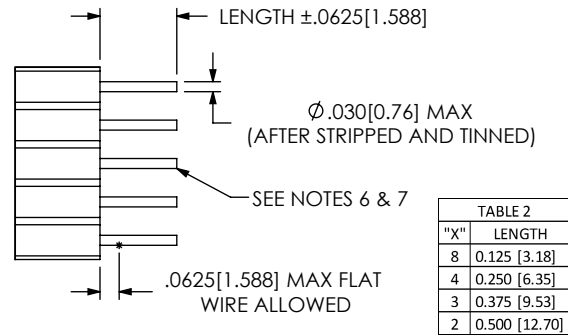

FIG 7

-ST"X": STRIPPED AND TINNED
(DIFFERENT AS SHOWN, OTHERWISE SAME AS FIG1)
(NOT AVAILABLE IN 28 POS AND UP)

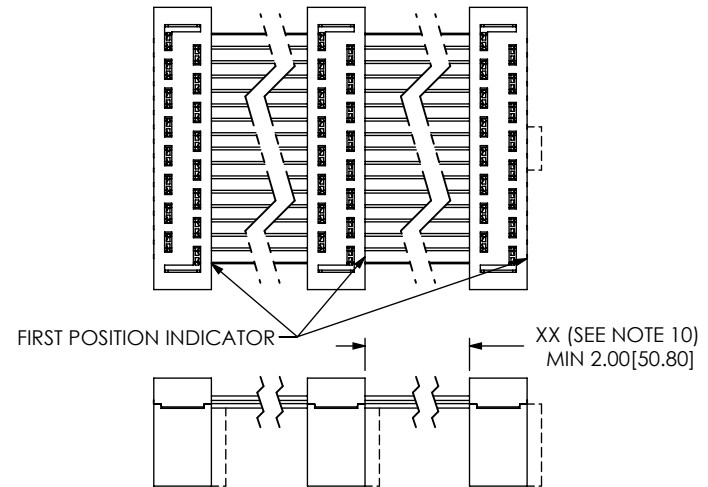

FIG 8

-D"XX": DAISY CHAIN DOUBLE
(DIFFERENT AS SHOWN, OTHERWISE SAME AS FIG1)
(2 INCH MIN WITH 1 INCH INCREMENTS)

BOTH SOCKETS REVERSED
WHEN DAISY CHAINED

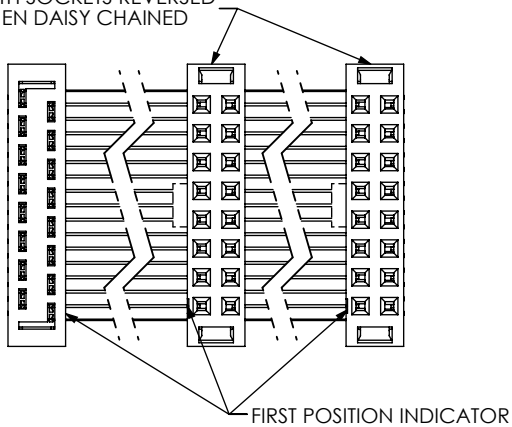
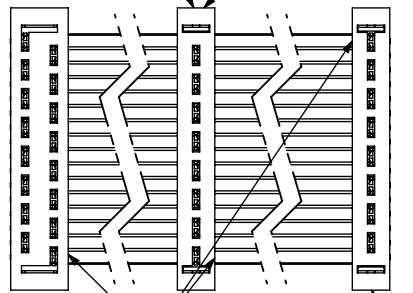

FIG 9

-R: REVERSE CONNECTOR
(DIFFERENT AS SHOWN, OTHERWISE SAME AS FIG1)

MIDDLE SINGLE TO TERMINATE
TO CONDUCTOR #1

HCSS-XX-01-X



XX (SEE NOTE 10)
MIN 2.00[50.80]

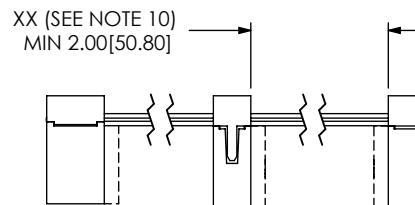

FIG 10

-W"XX": WIRING REVERSED
(DIFFERENT AS SHOWN, OTHERWISE SAME AS FIG1)

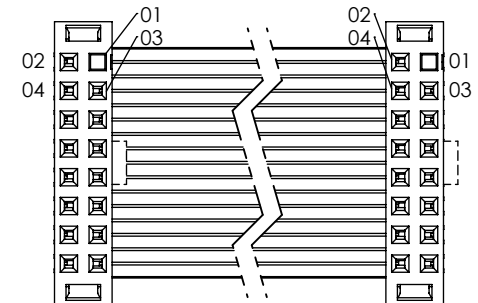

FIG 11

-P"XX": POLARIZED MATING
(DIFFERENT AS SHOWN, OTHERWISE SAME AS FIG1)
XX = POSITION NO
INSERT POLARIZING KEY PART NO PK-06-N
INTO SPECIFIED POSITION -XX (BOTH ENDS)

PROPRIETARY NOTE

THIS DOCUMENT CONTAINS CONFIDENTIAL AND PROPRIETARY INFORMATION AND ALL DESIGN, MANUFACTURING, REPRODUCTION, USE, PATENT RIGHTS AND SALES RIGHTS ARE EXPRESSLY RESERVED BY SAMTEC, INC. THIS DOCUMENT SHALL NOT BE DISCLOSED, IN WHOLE OR PART, TO ANY UNAUTHORIZED PERSON OR ENTITY NOR REPRODUCED, TRANSFERRED OR INCORPORATED IN ANY OTHER PROJECT IN ANY MANNER WITHOUT THE EXPRESS WRITTEN CONSENT OF SAMTEC, INC.



520 PARK EAST BLVD, NEW ALBANY, IN 47150
PHONE: 812-944-6733 FAX: 812-948-5047
e-Mail info@SAMTEC.com code 55322

DO NOT SCALE DRAWING

SHEET SCALE: 3:2

DESCRIPTION: .100 CL MOLD TO POS DOUBLE
ROW FEMALE ASSEMBLY

DWG. NO.
HCSD-XX-X-XX.XX-01-XXX-XXX

BY: KOLB 08/03/1990 SHEET 2 OF 4

END SINGLE TO TERMINATE TO CONDUCTOR #2

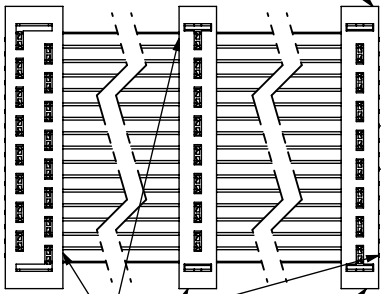

FIRST POSITION INDICATOR
MIDDLE SINGLE TO TERMINATE TO CONDUCTOR #1

HCSS-XX-01-X

XX (SEE NOTE 10)
MIN 2.00[50.80]

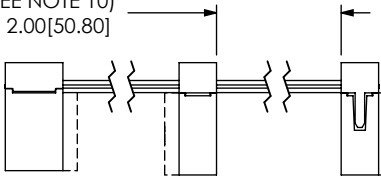
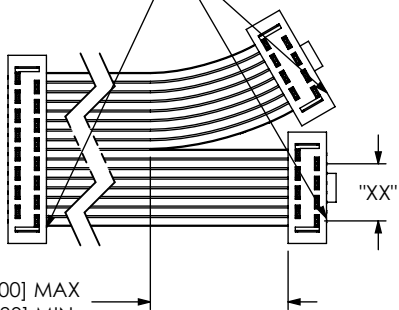

FIG 12

-S"XX": DAISY CHAIN SINGLE
(SAME AS FIG 1, DIFFERENT AS SHOWN)
2 INCH MIN WITH 1 INCH INCREMENTS
SCALE: 3:2

FIRST POSITION INDICATOR



5.000[127.00] MAX
2.000[50.80] MIN

FIG 15

-BXX: BREAKOUT OPTION
(SAME AS FIG 1, DIFFERENT AS SHOWN)
"XX" = NO OF CONDUCTORS BROKEN OUT FROM THE FIRST POSITION
(HCSD-08-XX.XX-01-N-B04 SHOWN)

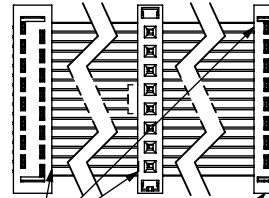

FIRST POSITION INDICATOR

HCSS-XX-01-X

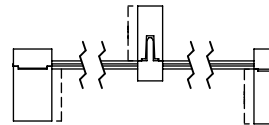
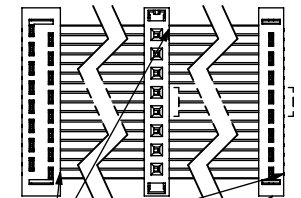

FIG 13

-W"XX"-M: MIDDLE REVERSED
(SAME AS FIG 1, DIFFERENT AS SHOWN)



FIRST POSITION INDICATOR

HCSS-XX-01-X

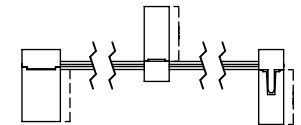
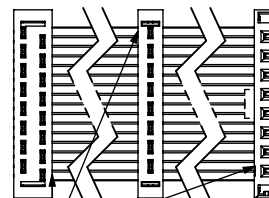

FIG 14

-S"XX"-M: MIDDLE REVERSED
(SAME AS FIG 1, DIFFERENT AS SHOWN)



FIRST POSITION INDICATOR

HCSS-XX-01-X

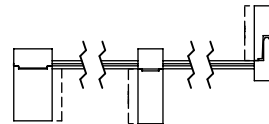
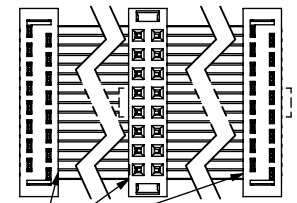

FIG 16

-S"XX"-O: OUTSIDE REVERSED
(SAME AS FIG 1, DIFFERENT AS SHOWN)



FIRST POSITION INDICATOR

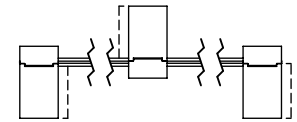

FIG 17

-D"XX"-M: MIDDLE REVERSED
(SAME AS FIG 1, DIFFERENT AS SHOWN)

PROPRIETARY NOTE

THIS DOCUMENT CONTAINS CONFIDENTIAL AND PROPRIETARY INFORMATION AND ALL DESIGN, MANUFACTURING, REPRODUCTION, USE, PATENT RIGHTS AND SALES RIGHTS ARE EXPRESSLY RESERVED BY SAMTEC, INC. THIS DOCUMENT SHALL NOT BE DISCLOSED, IN WHOLE OR PART, TO ANY UNAUTHORIZED PERSON OR ENTITY NOR REPRODUCED, TRANSFERRED OR INCORPORATED IN ANY OTHER PROJECT IN ANY MANNER WITHOUT THE EXPRESS WRITTEN CONSENT OF SAMTEC, INC.



520 PARK EAST BLVD, NEW ALBANY, IN 47150
PHONE: 812-944-6733 FAX: 812-948-5047
e-Mail info@SAMTEC.com code 55322

DO NOT SCALE DRAWING

SHEET SCALE: 1:1

DESCRIPTION: .100 CL MOLD TO POS DOUBLE ROW FEMALE ASSEMBLY

DWG. NO. HCSD-XX-X-XX.XX-01-XXX-XXX

BY: KOLB 08/03/1990 SHEET 3 OF 4

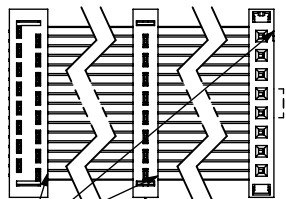

FIRST POSITION INDICATOR

HCSS-XX-01-X

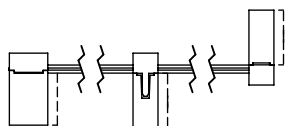
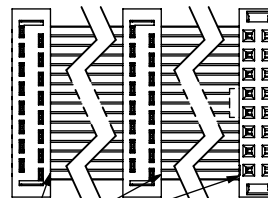

FIG 18

-W"XX"-O: OUTSIDE REVERSED
(SAME AS FIG 1, DIFFERENT AS SHOWN)



FIRST POSITION INDICATOR

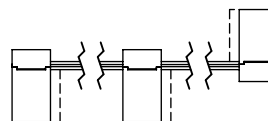

FIG 19

-D"XX"-O: OUTSIDE REVERSED
(SAME AS FIG 1, DIFFERENT AS SHOWN)

CRITICAL DIMENSION INSPECTION INSTRUCTION TABLE

ASSEMBLY OPERATION

IN-PROCESS INSPECTION

ASSEMBLE CB-XX-28-7/36-050-C

C1, C2

PROPRIETARY NOTE

THIS DOCUMENT CONTAINS CONFIDENTIAL AND PROPRIETARY INFORMATION AND ALL DESIGN, MANUFACTURING, REPRODUCTION, USE, PATENT RIGHTS AND SALES RIGHTS ARE EXPRESSLY RESERVED BY SAMTEC, INC. THIS DOCUMENT SHALL NOT BE DISCLOSED, IN WHOLE OR PART, TO ANY UNAUTHORIZED PERSON OR ENTITY NOR REPRODUCED, TRANSFERRED OR INCORPORATED IN ANY OTHER PROJECT IN ANY MANNER WITHOUT THE EXPRESS WRITTEN CONSENT OF SAMTEC, INC.



520 PARK EAST BLVD, NEW ALBANY, IN 47150
PHONE: 812-944-6733 FAX: 812-948-5047
e-Mail info@SAMTEC.com code 55322

DO NOT SCALE DRAWING

SHEET SCALE: 1:1

DESCRIPTION: .100 CL MOLD TO POS DOUBLE ROW FEMALE ASSEMBLY

DWG. NO.
HCSD-XX-X-XX.XX-01-XXX-XXX

BY: KOLB 08/03/1990 SHEET 4 OF 4