



Chipsmall Limited consists of a professional team with an average of over 10 year of expertise in the distribution of electronic components. Based in Hongkong, we have already established firm and mutual-benefit business relationships with customers from,Europe,America and south Asia,supplying obsolete and hard-to-find components to meet their specific needs.

With the principle of "Quality Parts,Customers Priority,Honest Operation,and Considerate Service",our business mainly focus on the distribution of electronic components. Line cards we deal with include Microchip,ALPS,ROHM,Xilinx,Pulse,ON,Everlight and Freescale. Main products comprise IC,Modules,Potentiometer,IC Socket,Relay,Connector.Our parts cover such applications as commercial,industrial, and automotives areas.

We are looking forward to setting up business relationship with you and hope to provide you with the best service and solution. Let us make a better world for our industry!



Contact us

Tel: +86-755-8981 8866 Fax: +86-755-8427 6832

Email & Skype: info@chipsmall.com Web: www.chipsmall.com

Address: A1208, Overseas Decoration Building, #122 Zhenhua RD., Futian, Shenzhen, China



PART NAME

NEMA HEAVY DUTY PLASTIC BOX

PART No.

HD-7600

REVISION DATE

10-4-10

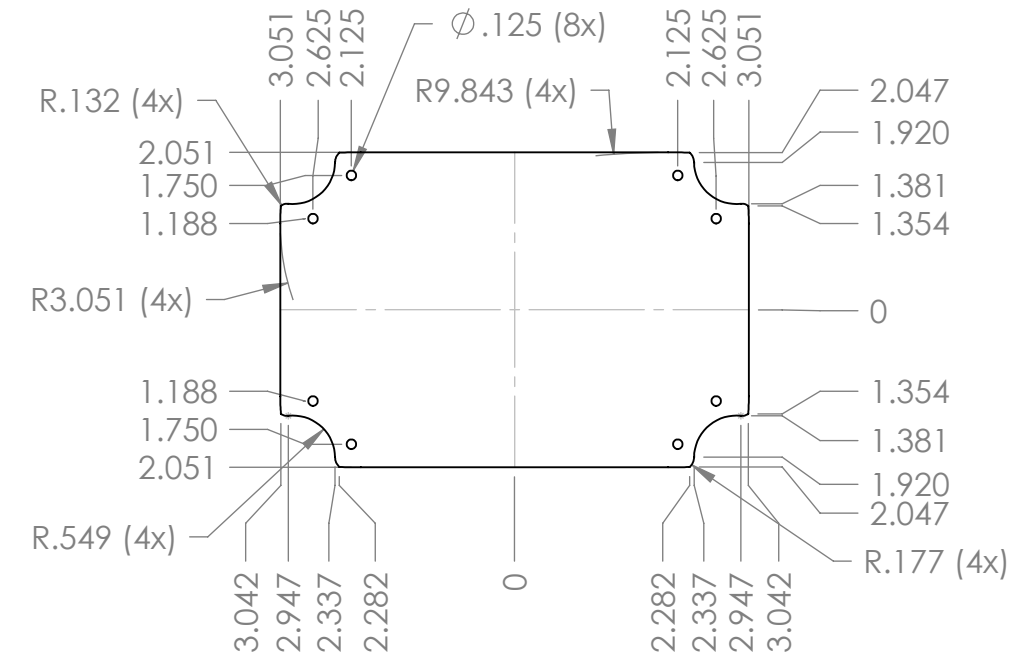
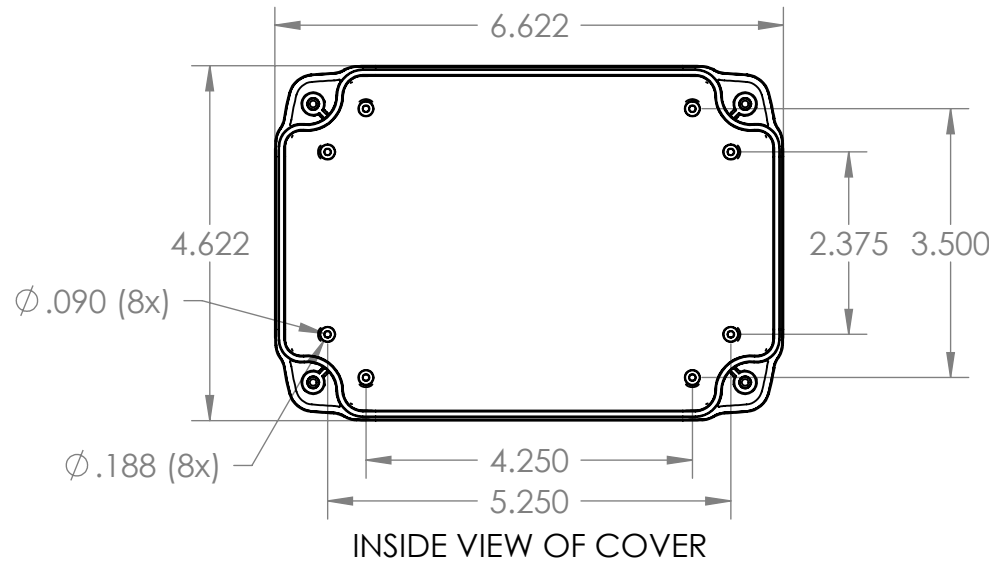
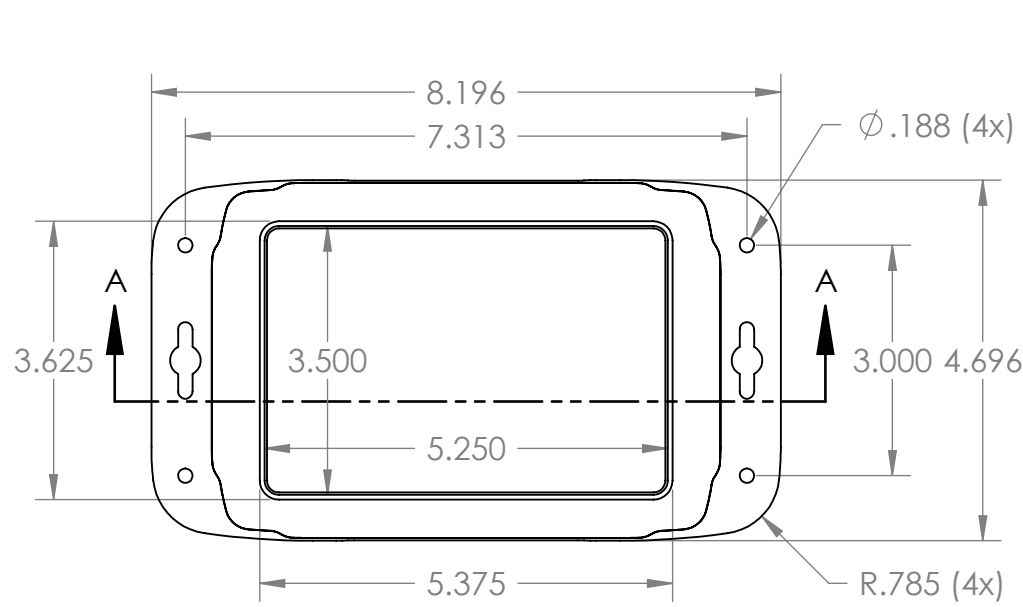

REFERENCE MAXIMUM P.C.B. SIZE.
 SIZES INCLUDE .03 CLEARANCE FROM INNER WALLS
 AND SCREW TOWERS WHEN UTILIZING THE MOUNTING
 BOSSES IN THE COVER. (CUSTOMER TO PROVIDE)

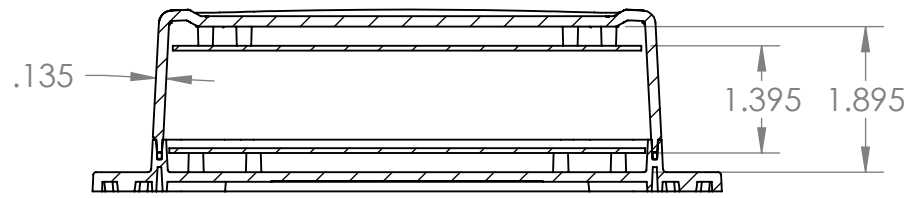

SECTION A-A

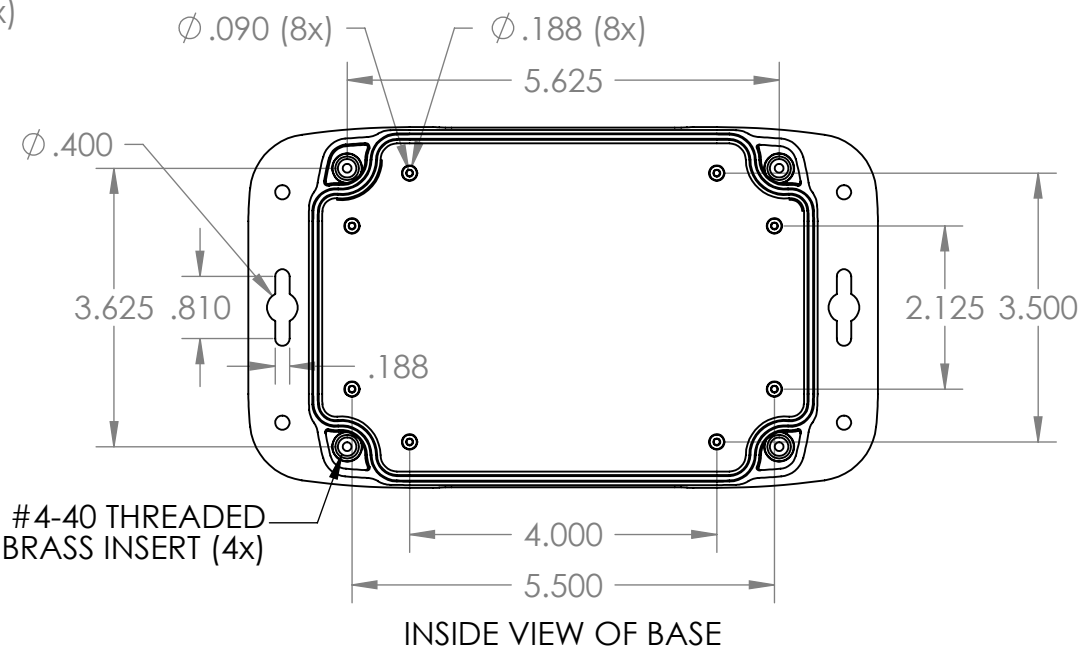

INSIDE VIEW OF BASE

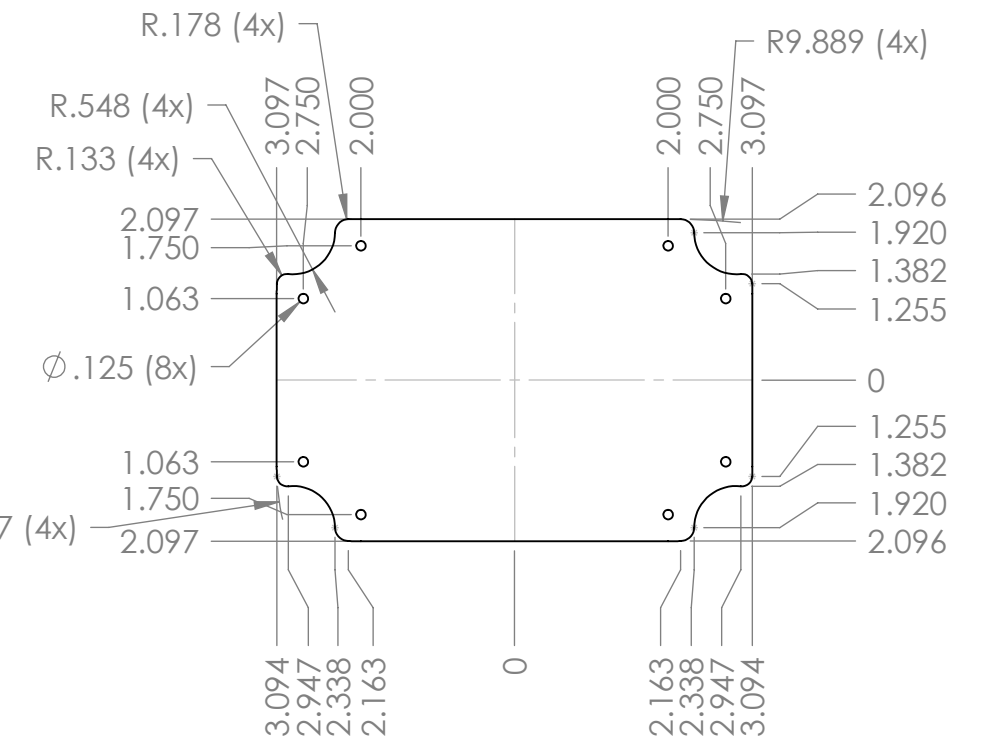

REFERENCE MAXIMUM P.C.B. SIZE.
 SIZES INCLUDE .03 CLEARANCE FROM INNER WALLS
 AND SCREW TOWERS WHEN UTILIZING THE MOUNTING
 BOSSES IN THE BASE. (CUSTOMER TO PROVIDE)

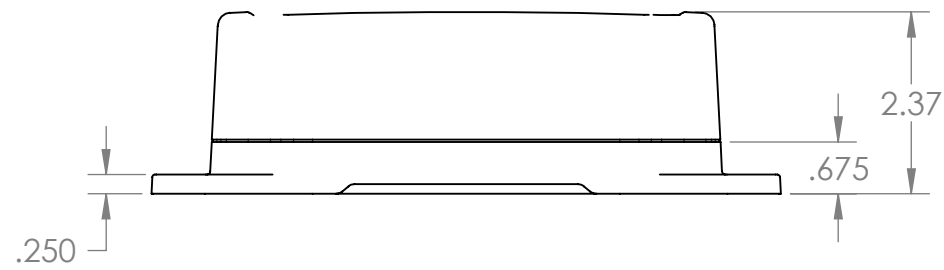

ALL DIMENSIONS HAVE ±.015 TOLERANCE

MATERIAL: BASE & COVER - POLYCARBONATE
 UL94-V0 AND UV STABILIZED
 FINISH: TEXTURED BLACK
 GASKET SILICONE RUBBER

ENCLOSURE DESIGNED TO IP 66 OF IEC 529
 AND NEMA 4, 4X, 12, 13
 FOUR (4) #4-40 x 7/8 LG. PAN HEAD STAINLESS
 STEEL SCREWS SUPPLIED FOR ASSEMBLY OF COVER
 RECOMMENDED TORQUE SETTING FOR ASSEMBLY
 SCREWS : 6.25 IN-LBS.
 PCB BOSSES WILL ACCEPT A #4 x 1/4 LG. THREAD
 FORMING SCREW (NOT SUPPLIED)

