



Chipsmall Limited consists of a professional team with an average of over 10 year of expertise in the distribution of electronic components. Based in Hongkong, we have already established firm and mutual-benefit business relationships with customers from,Europe,America and south Asia,supplying obsolete and hard-to-find components to meet their specific needs.

With the principle of “Quality Parts,Customers Priority,Honest Operation,and Considerate Service”,our business mainly focus on the distribution of electronic components. Line cards we deal with include Microchip,ALPS,ROHM,Xilinx,Pulse,ON,Everlight and Freescale. Main products comprise IC,Modules,Potentiometer,IC Socket,Relay,Connector.Our parts cover such applications as commercial,industrial, and automotives areas.

We are looking forward to setting up business relationship with you and hope to provide you with the best service and solution. Let us make a better world for our industry!



## Contact us

Tel: +86-755-8981 8866 Fax: +86-755-8427 6832

Email & Skype: info@chipsmall.com Web: www.chipsmall.com

Address: A1208, Overseas Decoration Building, #122 Zhenhua RD., Futian, Shenzhen, China



REVISIONS						
LOC	DIST	P	LTR	DESCRIPTION	DATE	APVD
-	-	H		REVISED PER E.O. P17744	11DEC2002	RDR
		J		REVISED PER E.O. P19419	11DEC2006	RDR
		K		REVISED PER E.O. P21366	4JUN2012	RDR
		K1		REVISED PER ECO-14-002953	29JAN2014	PV DM

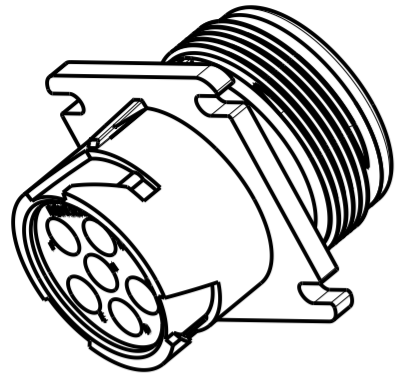

**3-D VIEW**

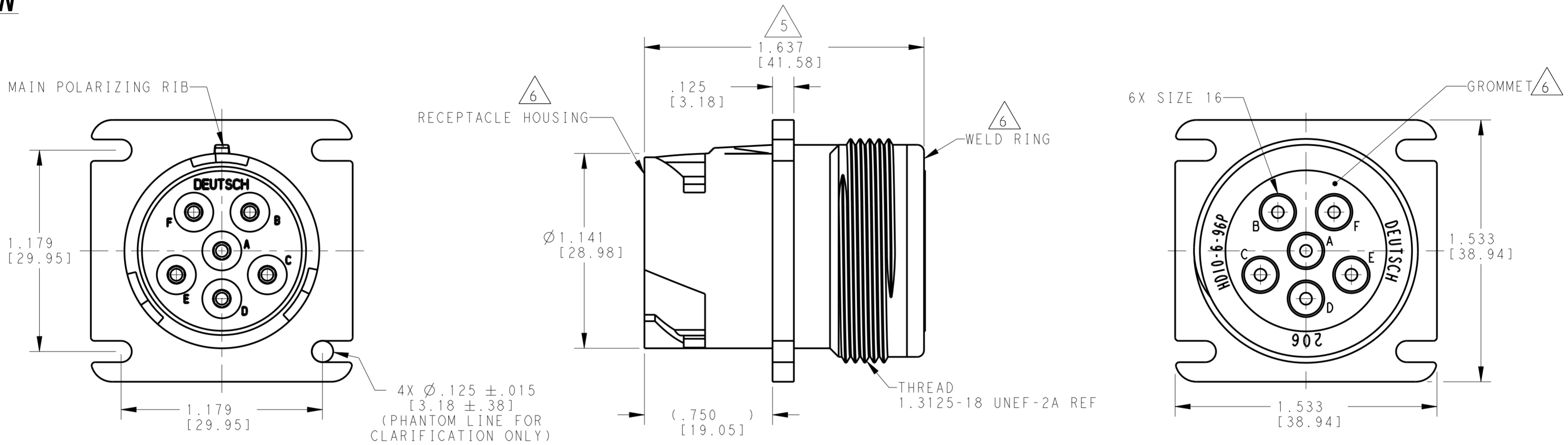

- 6. MATERIAL:  
RECEPTACLE HOUSING AND WELD RING: PA 15%GF (GREY)  
GROMMET: SILICONE (RED)
- 5. OVERALL DIMENSION DOES NOT INCLUDE RUBBER GROMMET.
- 4. THIS RECEPTACLE MATES WITH FOLLOWING PLUG (X= SEAL TYPE, XXXX= ALL MODIFICATIONS).  
HD16-6-96SX-XXXX
- 3. SEE DRAWING 0425-015-0000 FOR CONTACT AND WIRE PERFORMANCE AND APPLICATION CHARACTERISTICS.
- 2. MAXIMUM PANEL THICKNESS IS .250 [6.35].

1. SEE TABLE FOR USABLE WIRE RANGE AND INSULATION RANGE.

CONTACT SIZE	MINIMUM O.D.	MAXIMUM O.D.	WIRE RANGE [mm <sup>2</sup> ]
16	.100 [2.54]	.150 [3.81]	14-20 AWG [2.0-.50]

NOTES:

THIS DRAWING IS A CONTROLLED DOCUMENT.

DIMENSIONS: INCHES [mm]	TOLERANCES UNLESS OTHERWISE SPECIFIED:	DWN R. OCHOA 18SEP1998	TE Connectivity
	0 PLC ±	CHK I. GRANTCHAROVA 16SEP2013	
	1 PLC ±	APVD D. MEYER 18SEP2013	
	2 PLC ±	NAME	
MATERIAL	FINISH	PRODUCT SPEC	RECEPTACLE CONNECTOR SQUARE FLANGE HD10 SERIES ARR. 6-96 COLOUR: GREY
		APPLICATION SPEC	SIZE CAGE CODE DRAWING NO
		WEIGHT 34.55 (g)	A200779 C-HD10-6-96P
		Customer Drawing	RESTRICTED TO
		SCALE 2:1	SHEET 1 OF 1
			REV K1