



Chipsmall Limited consists of a professional team with an average of over 10 year of expertise in the distribution of electronic components. Based in Hongkong, we have already established firm and mutual-benefit business relationships with customers from,Europe,America and south Asia,supplying obsolete and hard-to-find components to meet their specific needs.

With the principle of “Quality Parts,Customers Priority,Honest Operation,and Considerate Service”,our business mainly focus on the distribution of electronic components. Line cards we deal with include Microchip,ALPS,ROHM,Xilinx,Pulse,ON,Everlight and Freescale. Main products comprise IC,Modules,Potentiometer,IC Socket,Relay,Connector.Our parts cover such applications as commercial,industrial, and automotives areas.

We are looking forward to setting up business relationship with you and hope to provide you with the best service and solution. Let us make a better world for our industry!



Contact us

Tel: +86-755-8981 8866 Fax: +86-755-8427 6832

Email & Skype: info@chipsmall.com Web: www.chipsmall.com

Address: A1208, Overseas Decoration Building, #122 Zhenhua RD., Futian, Shenzhen, China



ESD protection and signal conditioning for HDMI™ 2.0 source interface

Datasheet – production data

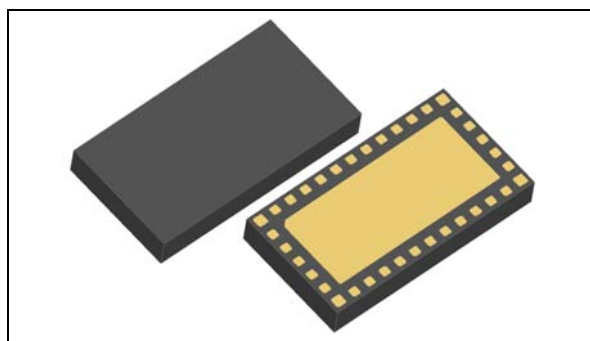

Features

- HDMI™ 2.0 (4K/2K 60fps) compliant from -40 to 85 °C
- TMDS high bandwidth and very low clamping voltage ESD protection
- 8 kV contact ESD protection on connector side
- Supports direct connection to low-voltage HDMI™ ASIC and/or CEC driver (down to 1.8 V)
- DDC capacitive decoupling between ASIC and HDMI™ connector and dynamic pull-up for long cable driving
- Back drive protection on 5 V, DDC bus and CEC
- CEC independent structure from main power supply
- HDMI™ Ethernet and audio return channel (HEAC) compatible
- HPD pull down and signal conditioning
- Short-circuit protection on 5 V output
- Proposed in QFN 36 leads 500 µm pitch

Benefits

- Easy hardware design and speed-up certification of HDMI™ 2.0
- Pin map sequence compliant with HDMI™ connector type A

- High integration level for minimal PCB footprint
- Efficient protection of sensitive HDMI™ ASICs
- Very low power consumption in stand-by mode
- Wake-up from stand-by through CEC bus
- Allow to drive long cable and poor quality cable
- Companion chip for STMicroelectronics' STixxxx HDMI™ decoders

Complies with the following standards

- HDMI™ 2.0 version
- IEC 61000-4-2 level 4
- JESD22-A114D level 2

Applications

- Consumer and computer electronics HDMI™ source device such as:
 - Set-top boxes / ADSL boxes
 - DVD and Blu-Ray disk systems
 - Notebook / PC graphic cards
 - Game console
 - Home theater

Description

The HDMI2C1-14HD is a fully integrated ESD protection and signal conditioning device for control links and TMDS data video channels of HDMI™ transmitters (source).

The HDMI2C1-14HD is a simple solution that provides HDMI™ designers with an easy and fast way to reach full compliance with the stringent HDMI™ 2.0 (4K/2K 60fps) on a wide temperature range.

TM: HDMI: the HDMI logo and High-Definition Multimedia Interface are trademarks or registered trademarks of HDMI Licensing LLC.

Contents

- 1 Functional description 3**
- 2 Application information 5**
 - 2.1 CEC line description 5
 - 2.2 DDC functional block description 6
 - 2.3 HEAC link and HPD line description 9
 - 2.3.1 HPD line description 9
 - 2.3.2 HEAC functional block description 10
 - 2.4 +5V protection and fault line functional block description 11
 - 2.5 Back drive protection 12
 - 2.6 TMDS channels ESD protection 12
 - 2.7 Application block diagrams 13
- 3 Electrical characteristics 17**
- 4 Package information 25**
 - 4.1 QFN package information 25
 - 4.2 Packing information 27
- 5 Recommendation on PCB assembly 28**
 - 5.1 Stencil opening design 28
 - 5.2 Solder paste 29
 - 5.3 Placement 29
 - 5.4 PCB design preference 29
 - 5.5 Reflow profile 30
- 6 Ordering information 31**
- 7 Revision history 31**

1 Functional description

The HDMI2C1-14HD is a fully integrated ESD protection and signal conditioning device for control links and TMDS data video channels of HDMI™ transmitters (source).

The control stage provides a bidirectional buffer, integrating signal conditioning and dynamic pull-up on DDC bus for maximum system robustness and signal integrity. The HEAC (HDMI Ethernet and audio return channels) function is supported, making the component fully compliant with HDMI 2.0 version. A bidirectional CEC block is integrated, able to wake-up the application from stand-by mode (all power supply off, except the CEC power supply). All video format specified by HDMI™ 2.0 standard like 1080p60 3D, 4K/2K 60fps are supported, giving maximal flexibility to designers. The +5 V supplied to the cable is protected against accidental surge current and short circuit. All these features are provided in a single 36 leads QFN package featuring natural PCB routing and saving space on the board.

The HDMI2C1-14HD is a simple solution that provides HDMI™ designers with an easy and fast way to reach full compliance with the stringent HDMI™ 2.0 on a wide temperature range. STMicroelectronics proposes a dual version dedicated for the sink interfaces: the HDMI2C2-14HD.

Figure 1. Pin out, top view

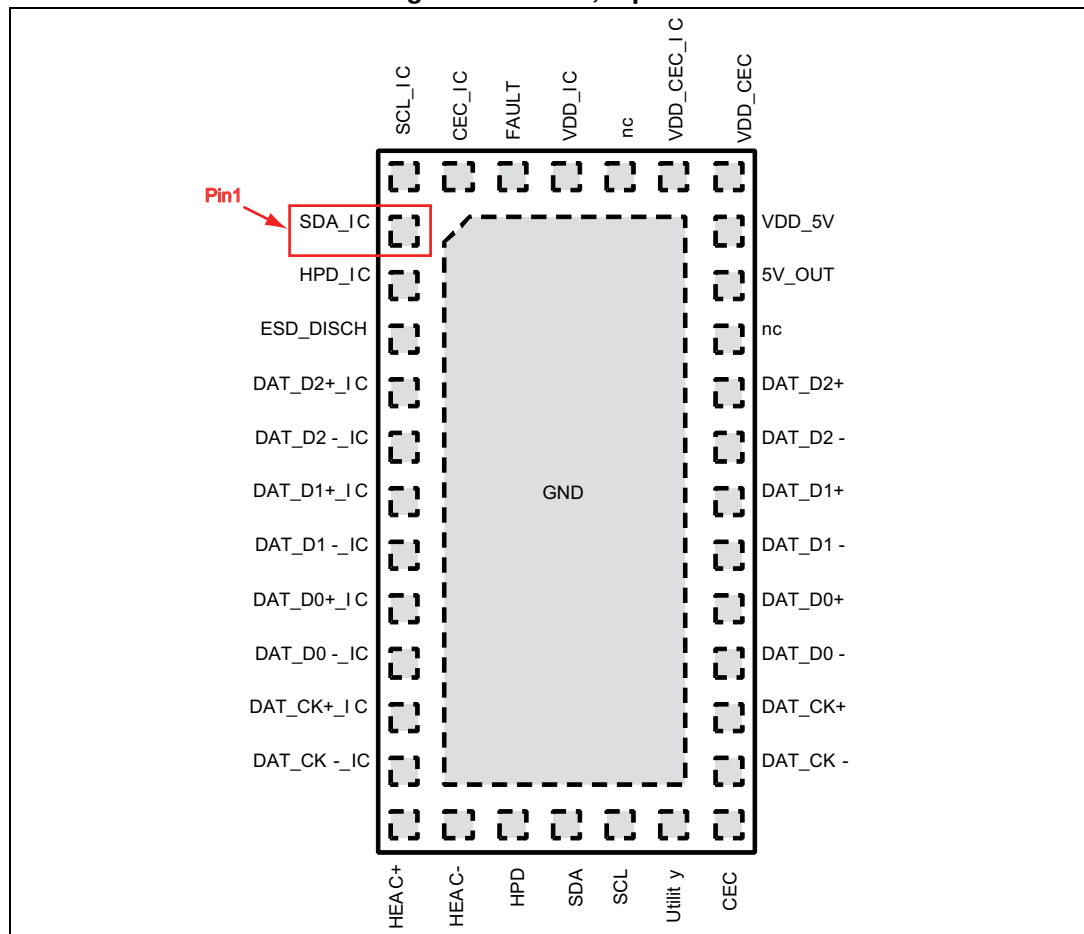
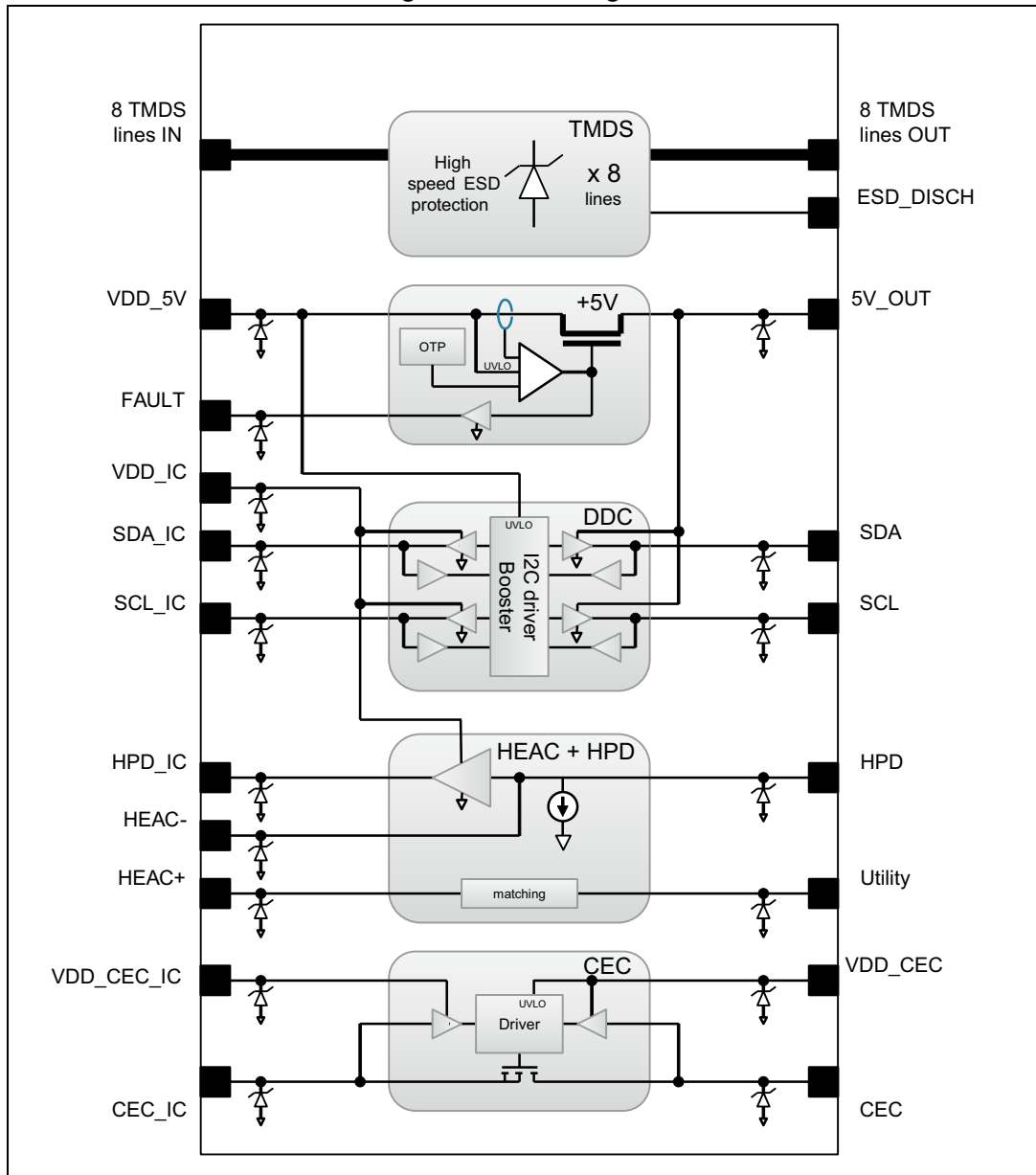

Figure 2. Block diagram



2 Application information

2.1 CEC line description

The CEC bus is described in the HDMI™ standards as the consumer electronics control. It provides control functions between all the various audiovisual equipments chained in the user's environment.

The CEC block integrated in the HDMI2C1-14HD implements a level shifter, shifting the cable CEC +3.3 V voltage (V_{DD_CEC}) down to the ASIC power supply voltage ($V_{DD_CEC_IC}$) that can be as low as 1.8 V. The *Figure 3* shows the functional diagram of the integrated CEC block.

Figure 3. CEC link functional diagram

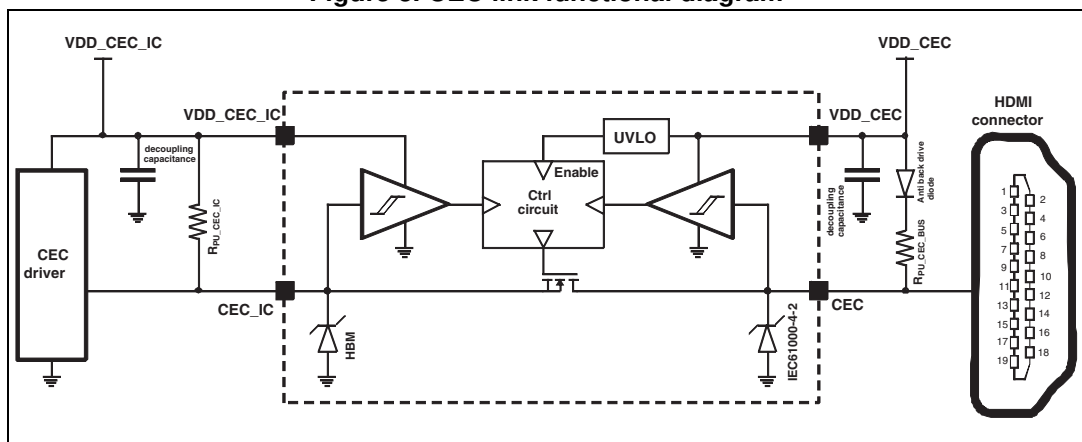

In case of no activity on the CEC bus, or if the CEC driver is off ($V_{DD_CEC_IC} = 0$), the CEC pin is put in high impedance mode (open circuit) protecting the circuitry and the application against hazardous back drive.

The *Figure 4* illustrates the normal operating mode of the CEC block when the IC from the source and when the sink drives the communication.

Figure 4. Simplified view of the electrical parameters of the CEC block

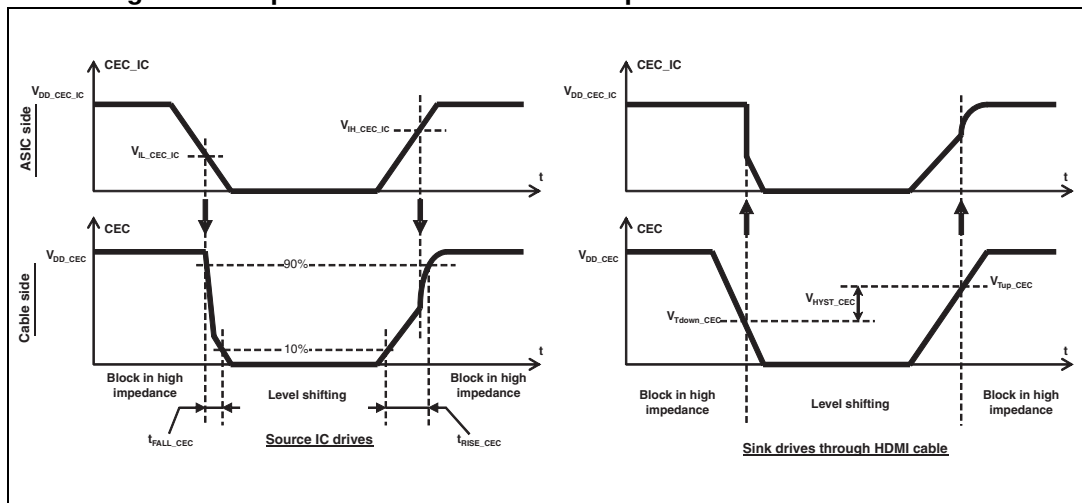

In case the application is set in stand-by mode, the +5 V main supply of the application is generally powered off in order to reduce as much as possible the global power consumption. The CEC driver can be the only device still working in low power mode, allowing a wake up of the whole application through the CEC line. When the main power supply +5 V is switched off, and if the CEC bus is still active (V_{DD_CEC} power in on state), the HDMI2C1-14HD keeps the CEC bus working properly while all other outputs of the component are put in high impedance mode.

The CEC output (cable side) integrates a protection against ESD which is compliant with IEC61000-4-2 standard, level 4 (8kV contact).

2.2 DDC functional block description

The DDC bus is described in the HDMI™ standards as the Display Data Channel. The topology corresponds to an I2C bus that must be compliant with the I2C bus specification version 5 (October 2012). The DDC bus is made of 2 lines: data line (SDA) and clock line (SCL). It is used to create a point to point communication link from the source to the sink. EEDID and HDCP protocols are flowing through this link, making this I2C communication channel a key element in the HDMI™ application.

The DDC block integrated in the HDMI2C1-14HD allows a bidirectional communication between the cable and the ASIC. It is fully compliant with the HDMI™ 2.0 standard and its CTS, and with the I2C bus specification version 2.1. It is shifting the 5V voltage from the cable (V_{5V_OUT}) down to the ASIC voltage level (V_{DD_IC}) that can be as low as 1.8 V. The [Figure 5](#) shows the functional diagram of the DDC block integrated in the HDMI2C1-14HD device.

Figure 5. DDC bus functional diagram (SCL and SDA lines)

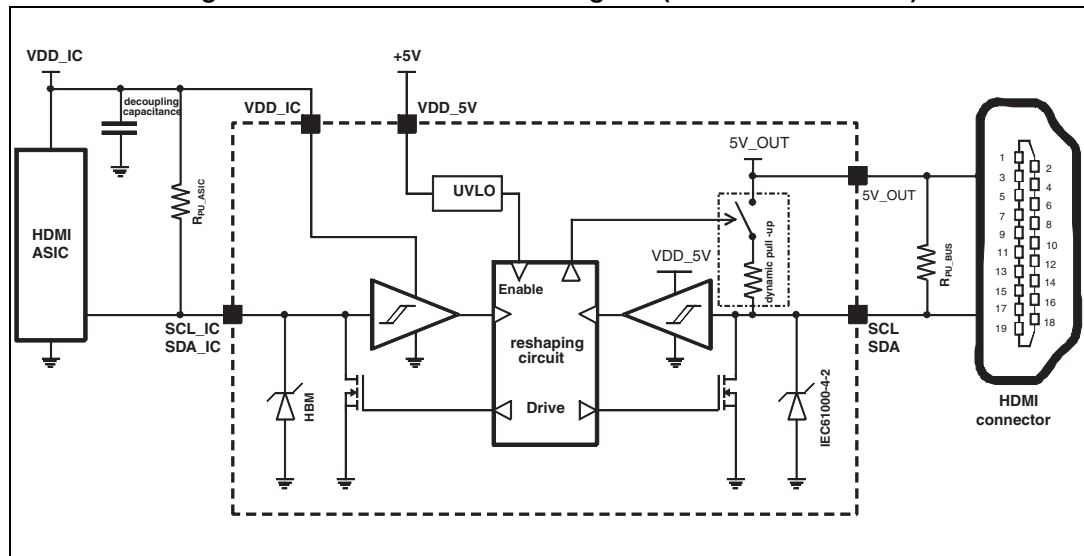

The [Figure 6](#) illustrates the electrical parameter of the DDC block specified in [Table 8](#).

Figure 6. Simplified view of the electrical parameters of the DDC block

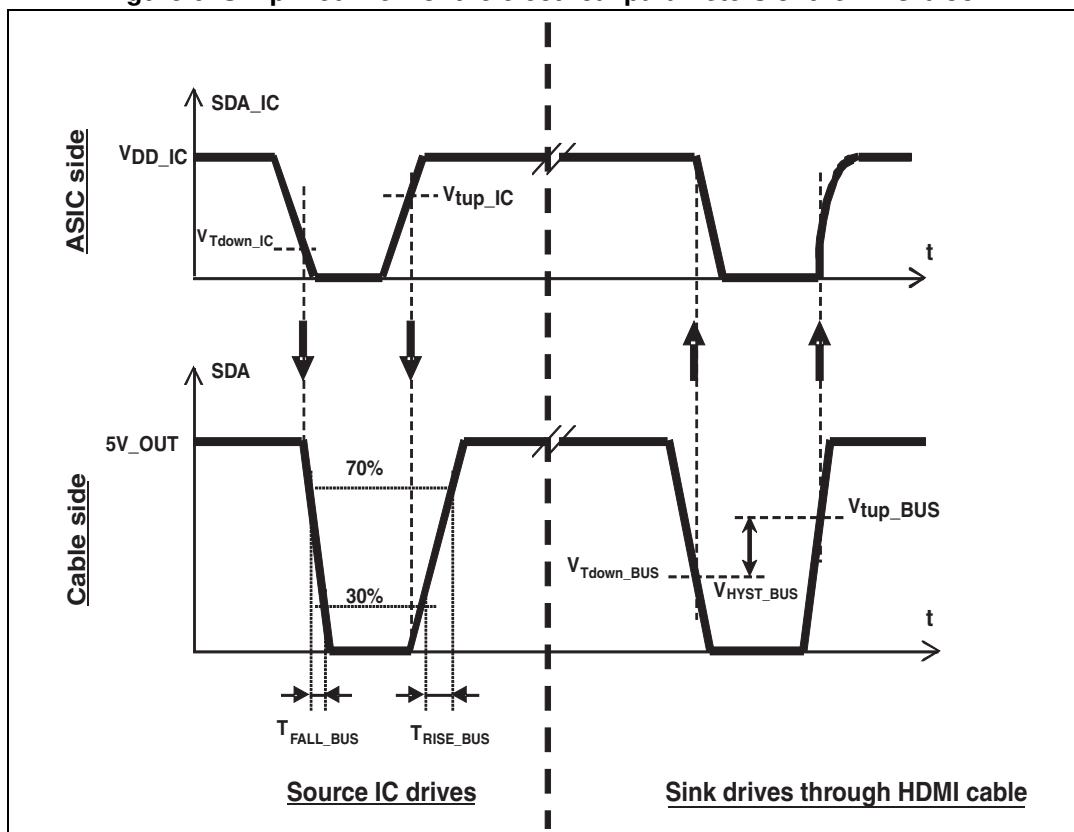

The HDMI™ standard specifies that the max capacitance of the cable can reach up to 700 pF. Knowing that the max capacitance of the sink input can reach up to 50 pF, this means that the I2C driver must be able to drive a load capacitance up to 750 pF. On the other hand, the I2C standard specifies a maximum rise time of the signal must be lower than 1 μs in order to keep the signal integrity. Taking into account the max cable capacitance of 750 pF, it is not possible to guarantee a rise time lower than 1 μs in worst case. Therefore, a dynamic pull-up has been integrated at the output of SDA and SCL lines and synchronized with the I2C driver. This signal booster accelerates for a short period the charging time of the equivalent cable capacitance, allowing to drive any HDMI™ cable. The [Figure 7](#) illustrates the benefit of the dynamic pull-up integrated in the HDMI2C1-14HD device.

Figure 7. Benefit of the dynamic pull-up on the DDC bus

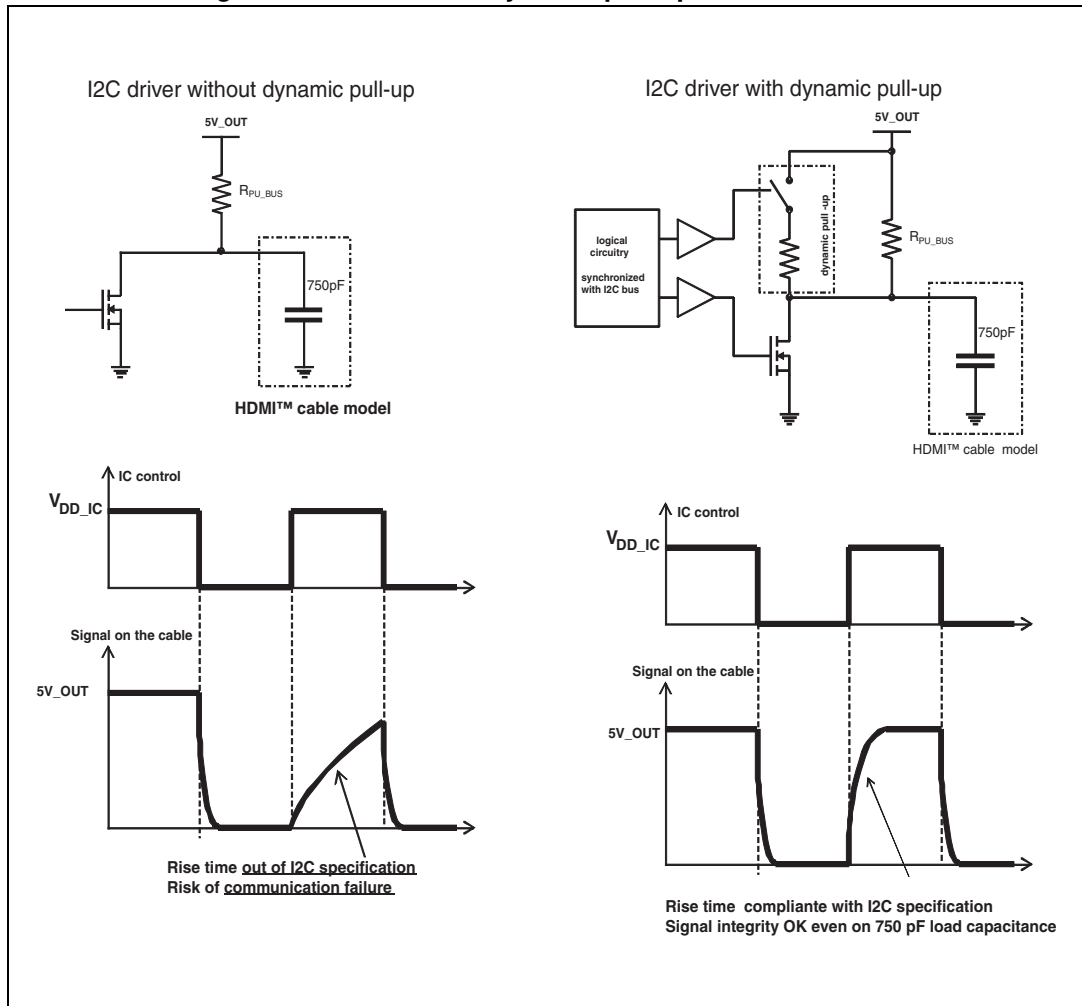

In order to activate the DDC block, the V_{DD_5V} has to reach the specified V_{DD_5V_ON} threshold (see [Table 4](#)). In addition, the inputs and outputs of the bidirectional level shifters (SCL, SDA, SCL_IC, SDA_IC) must be set to a high level after the power-on, and the HPD line has to be activated one time.

The DDC outputs (SCL and SDA on cable side) integrate a protection against ESD which is compliant with IEC61000-4-2 standard, level 4 (8 kV contact).

2.3 HEAC link and HPD line description

The HDMI2C1-14HD proposes a unique solution in order to manage and protect both the HEAC and the HPD links. The [Figure 8](#) shows an overview of the function diagram of the integrated block.

Figure 8. HEAC / HPD / Utility functional block diagram

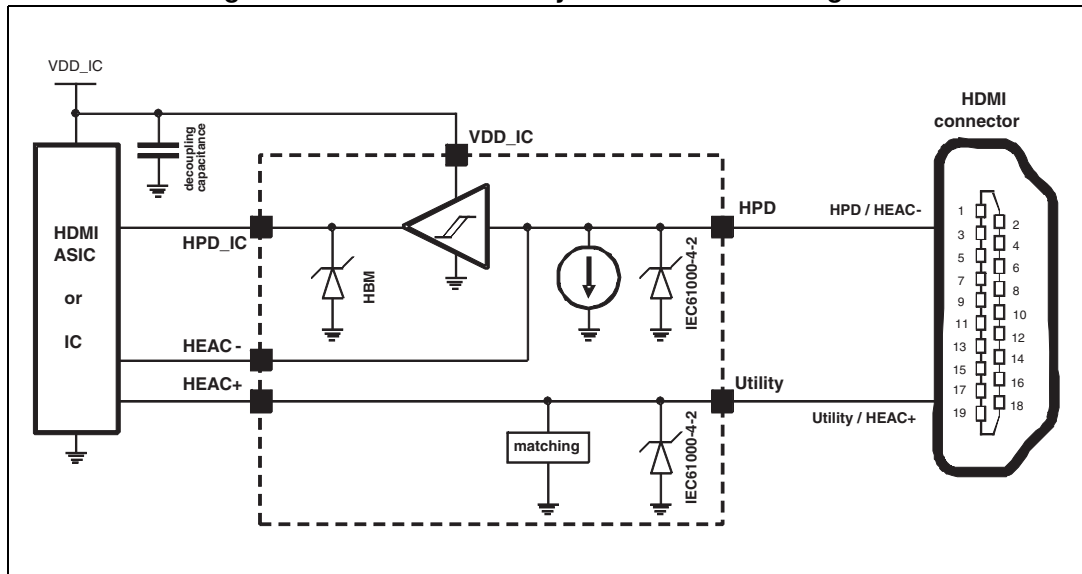

This block simplifies the design and the PCB layout of the HPD and HEAC functions. Simply connect the 2 pins from the HDMI connector to one side of the device, and then use the 3 dedicated links on the other side of the device to manage separately the HPD and the HEAC links.

Both HPD and Utility inputs (cable side) integrate a protection against ESD which is compliant with IEC61000-4-2 standard, level 4 (8 kV contact).

2.3.1 HPD line description

The HPD line is described in the HDMI™ standards as the Hot Plug Detect function. This line is used by the Source device in order to detect if a Sink device is connected through an HDMI cable.

The integrated HPD block is pulling down the line via a current source. When the input voltage is detected to be higher than a threshold level V_{TH_HPD} , the signal is converted into a high state level on the ASIC side, at the voltage level of the ASIC power supply V_{DD_IC} . Otherwise, HPD_IC pin remains in low state.

The electrical parameters relevant to the HPD block and specified by the [Table 7](#) are illustrated in the [Figure 9](#).

Figure 9. Simplified view of the electrical parameters of the HPD block

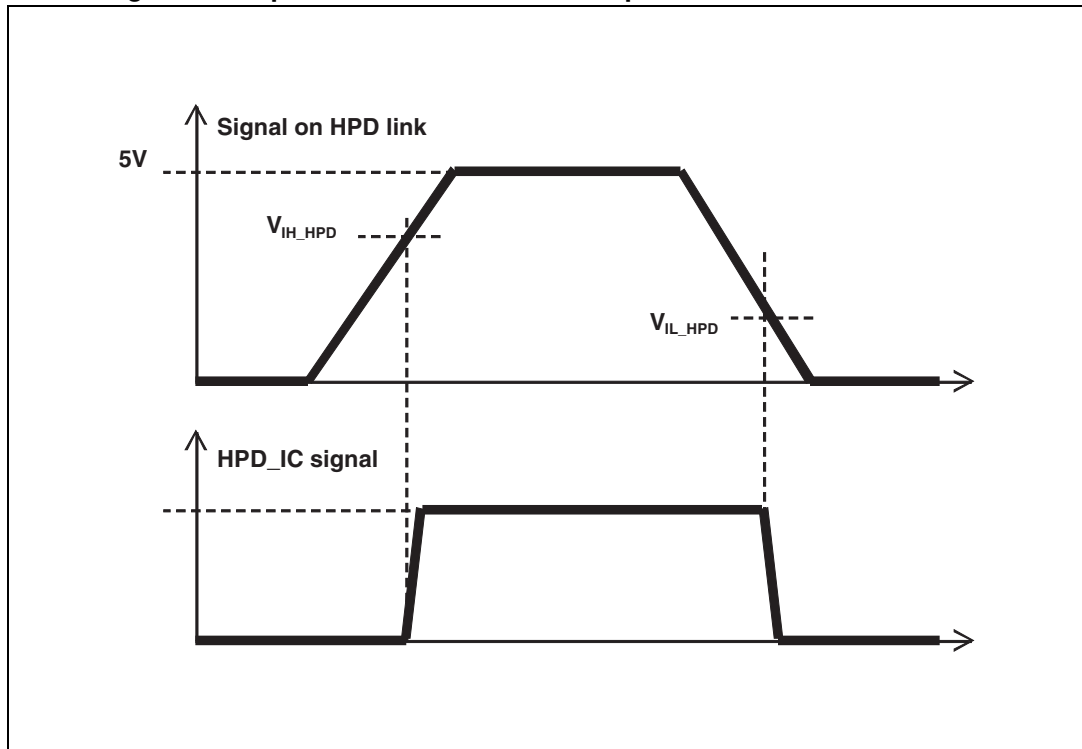

2.3.2 HEAC functional block description

The HEAC link is described in the HDMI™ 1.4 and HDMI™ 2.0 standards as the HDMI™ Ethernet and audio return channel. It corresponds physically to one differential wired pair made of the Utility line and the HPD line. Two signals are transmitted through this link.

The first signal corresponds to the HDMI™ Ethernet channel (HEC). The signal is transmitted in differential mode (bidirectional) through the HEAC link. It is specified by the 100Base-TX IEEE 802.3 standard (fast Ethernet 100Mbps over twisted pair). Therefore, the HEC integrates an Ethernet link into the video cable, enabling IP-based applications over the HDMI™ cable.

The second signal corresponds to the Audio Return Channel (ARC). The signal is transmitted either in common mode (unidirectional, from sink to source) through the HEAC link. It is specified by the IEC 60958-1 standard. The ARC function integrates an upstream audio capability, simplifying the cabling of the audiovisual equipment. It is no more necessary to use a coaxial cable from TV to audio amplifier.

The HDMI2C1-14HD helps the designer to implement this high added value HEAC function in the application, protecting the link against the ESD with no disturbance of the signal. It provides 2 distinct outputs HEAC+ and HEAC- in order to ease as much as possible the PCB layout.

2.4 +5V protection and fault line functional block description

The +5 V power supply that the source device has to provide to the HDMI™ cable is described by the HDMI™ 2.0 standard. It must be protected against accidental short circuit that could occur on the cable side.

The HDMI2C1-14HD device embeds a low drop current limiter. If an over-current is detected, the HDMI2C1-14HD limits the current through the +5 V power supply. If the current is too high (short circuit), the device opens the +5 V.

Furthermore, the HDMI2C1-14HD device embeds also an over temperature protection (OTP). If the internal temperature of the device reaches a too high value, the +5 V supply is opened in order to protect the application.

In case either the current limiter or the OTP is triggered, the fault pin switches down to low state level (open drain topology) in order to optionally inform the HDMI™ ASIC that an abnormal situation has been detected (option).

An under voltage lockout (UVLO) is also integrated in the block. It checks the main +5 V power supply state, and enables the 5V_OUT only if the main power supply has reached a minimal value $V_{DD_5V_ON}$.

The *Figure 10* shows the functional diagram of the current limiter block.

Figure 10. +5 V functional diagram

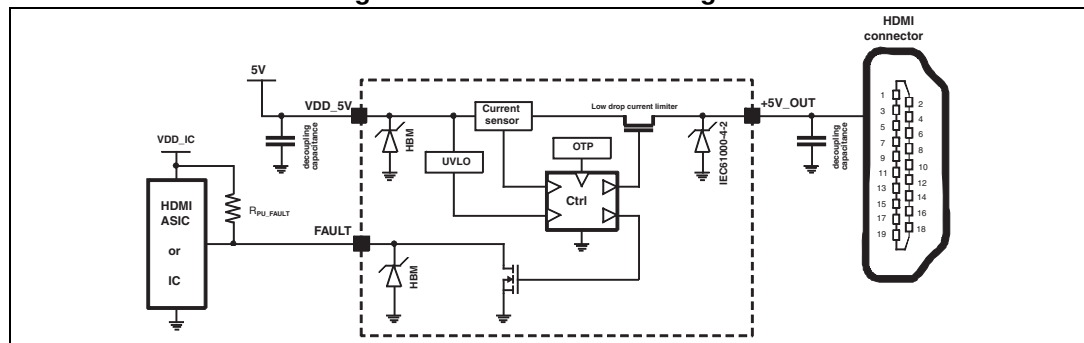

To summarize, the short circuit protection and the over temperature protection features are providing a high robustness level of the application. On top of this, the fault line can be used in order to improve the user experience.

The 5V_OUT pin integrates a protection against ESD which is compliant with IEC61000-4-2 standard, level 4 (8 kV contact). The decoupling capacitance is mandatory, according to the power management state of the art.

2.5 Back drive protection

Figure 11. Back drive current diagram

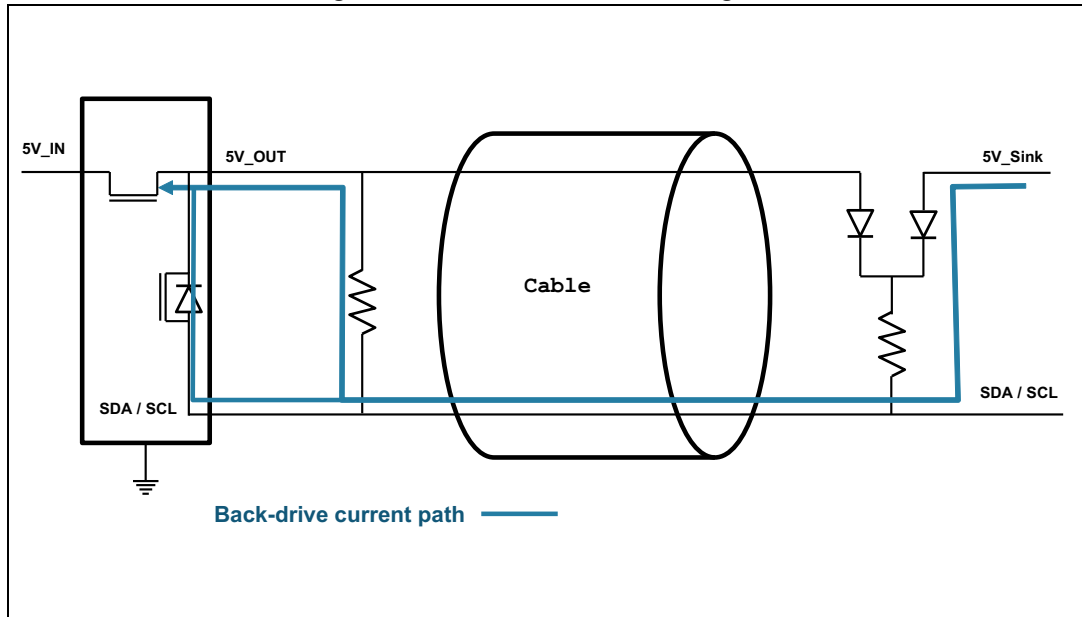

Thanks to the innovative switch architecture, back drive current is blocked whatever back drive current is coming from +5V_OUT and/or DDC lines (see figure 11).

In case of no activity on CEC bus, or if the CEC driver is off ($V_{DD_CEC} = 0$), the output CEC pin is put in high impedance mode (open circuit) protecting the circuitry and the application against hazardous back drive.

2.6 TMDS channels ESD protection

The TMDS (Transient Minimized Differential Signaling) channels are described by the HDMI 2.0 standard. A total of 4 unidirectional differential pairs are used to transmit the video data to the sink device. There are 3 channels dedicated to the video data, and 1 channel dedicated to the clock.

The HDMI2C1-14HD provides a simple PCB layout solution, directly compliant with HDMI connector type A. It protects the application against the ESD according to the IEC61000-4-2 level 4 standard (+/-8 kV contact). The high bandwidth of this ESD protection allows to transmit HD video data with no disturbance of the signal up to 5.94 Gbps per channel.

A capacitor can be optionally connected to the ESD_DISCH pin in order to enhance the ESD protection performances.

Figure 12. TMDS lines ESD protection functional diagram

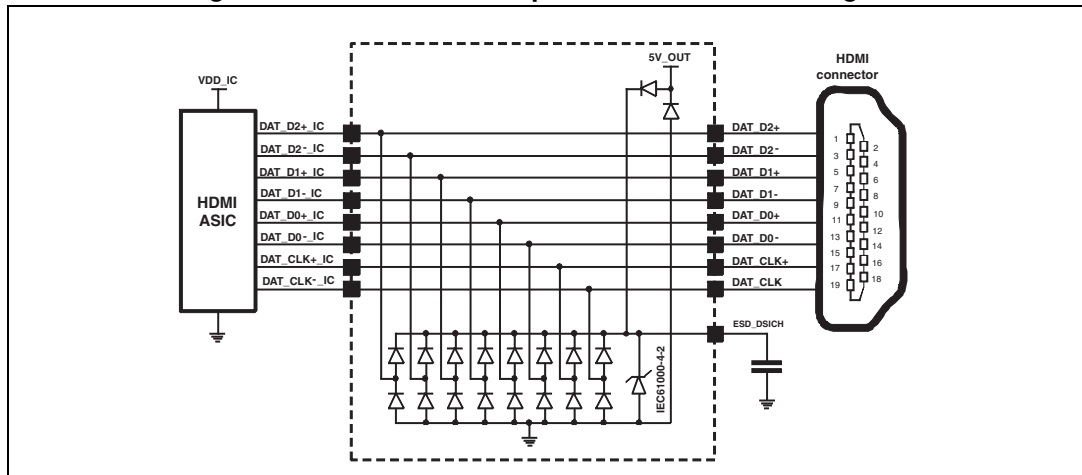

2.7 Application block diagrams

The [Figure 13](#) shows an application block diagram proposal, implementing all the possible options. The TMDS channels are simply connected to the connector and to the source HDMI ASIC. The diagram shows that the CEC driver can be totally independent from the HDMI ASIC. By this way, even if the +5 V power supply and/or if the HDMI ASIC is sleeping in stand-by mode, the CEC bus is still active in low power mode. The designer has then all the tools to optimize the power consumption of the global application in stand-by mode, and has the possibility to implement a smart wake-up through the CEC bus enhancing the final user experience.

Figure 13. Application block diagram

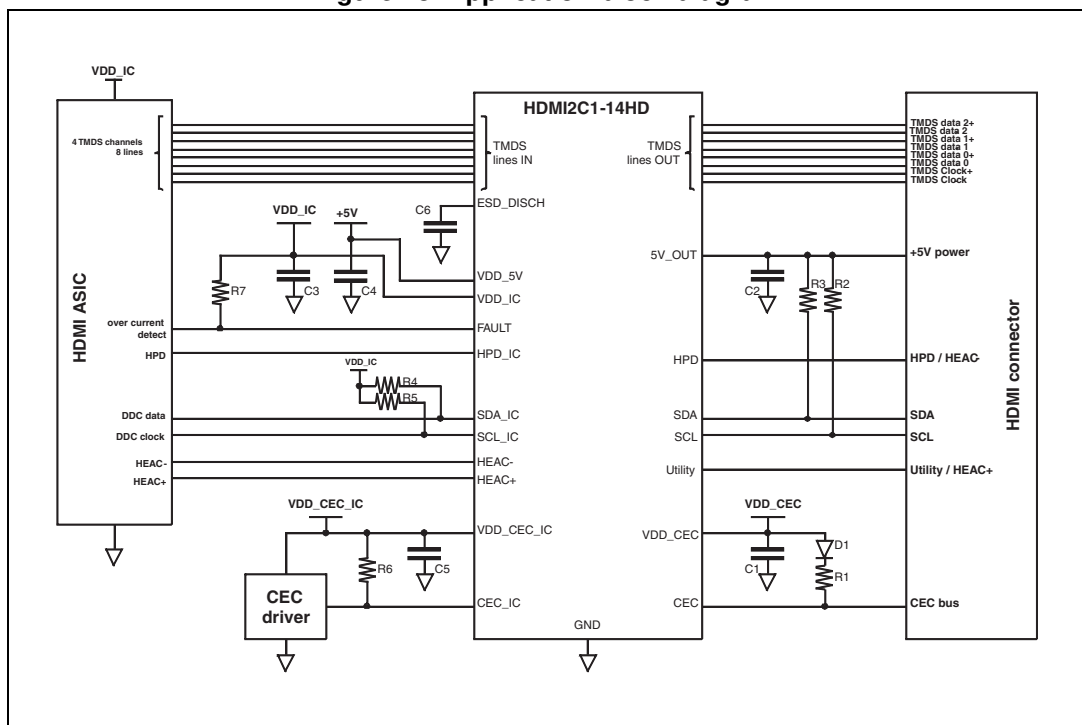
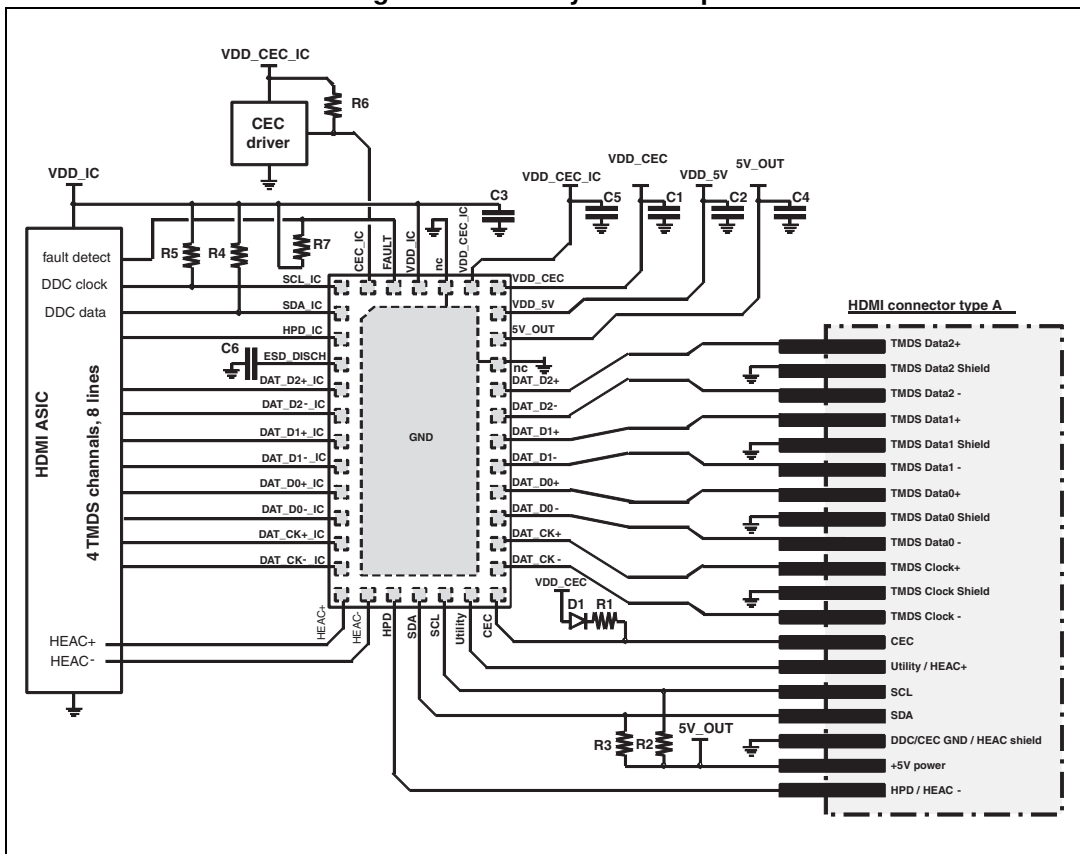

Table 1. Block diagrams references

| Ref. | Typical values | Comment |
|----------|----------------|--|
| R1 | 27 kΩ | Pull-up resistance on CEC bus, specified by the HDMI standard |
| R2, R3 | 1.8 kΩ | Pull-up resistances on DDC bus, specified by the HDMI standard |
| R4, R5 | 10 kΩ | Pull-up resistance on DDC bus, ASIC side, value selected to be compliant with I2C levels |
| R6 | 270 kΩ to 1 MΩ | Pull-up resistance on CEC line, ASIC side |
| R7 | 10 kΩ | Pull-up resistance on FAULT line (option) |
| D1 | BAT54 | Small Schottky diode blocking back drive current flowing toward the V _{DD_CEC} supply |
| C1 to C5 | 100 nF | Decoupling capacitance on power supplies |
| C6 | 1 μF | ESD protection enhancement capacitance (option) |

Note: SCL_IC, SDA_IC, and CEC_IC have to be driven with an ASIC working with open drain outputs.

Figure 14. PCB layout example



The Figure 14 illustrates the fact that the HDMI2C1-14HD pin configuration eases and optimizes the PCB layout of the HDMI interface. The proposed pin-out sequence is directly compliant with HDMI connector type A.

Table 2. Pin description

| Pin | Name | Description | Pin | Name | Description |
|-----|------------|--|-----|------------|----------------------------------|
| 1 | SDA_IC | DDC input ASIC side | 19 | DAT_CK- | TMDS output Clock CK- |
| 2 | HPD_IC | HPD output ASIC side | 20 | DAT_CK+ | TMDS output Clock CK+ |
| 3 | ESD_DISCH | ESD protection enhancement capacitance | 21 | DAT_D0- | TMDS output Data D0- |
| 4 | DAT_D2+_IC | TMDS input Data D2+ | 22 | DAT_D0+ | TMDS output Data D0+ |
| 5 | DAT_D2-_IC | TMDS input Data D2- | 23 | DAT_D1- | TMDS output Data D1- |
| 6 | DAT_D1+_IC | TMDS input Data D1+ | 24 | DAT_D1+ | TMDS output Data D1+ |
| 7 | DAT_D1-_IC | TMDS input Data D1- | 25 | DAT_D2- | TMDS output Data D2- |
| 8 | DAT_D0+_IC | TMDS input Data D0+ | 26 | DAT_D2+ | TMDS output Data D2+ |
| 9 | DAT_D0-_IC | TMDS input Data D0- | 27 | NC | not connected |
| 10 | DAT_CK+_IC | TMDS input Clock CK+ | 28 | 5V_OUT | +5V power supply HDMI cable side |
| 11 | DAT_CK-_IC | TMDS input Clock CK- | 29 | VDD_5V | +5V main power supply |
| 12 | HEAC+ | HEAC+ output ASIC side | 30 | VDD_CEC | CEC supply HDMI cable side |
| 13 | HEAC- | HEAC- output ASIC side | 31 | VDD_CEC_IC | CEC driver power supply |
| 14 | HPD | HPD/HEAC- input HDMI cable side | 32 | NC | not connected |
| 15 | SDA | DDC output HDMI cable side | 33 | VDD_IC | HDMI ASIC power supply |
| 16 | SCL | DDC output HDMI cable side | 34 | FAULT | Fault line output ASIC side |
| 17 | Utility | Utility/HEAC+ input HDMI cable side | 35 | CEC_IC | CEC input ASIC side |
| 18 | CEC | CEC output HDMI cable side | 36 | SCL_IC | DDC input ASIC side |
| | | | Pad | GND | Ground |

Figure 15. Pin numbering

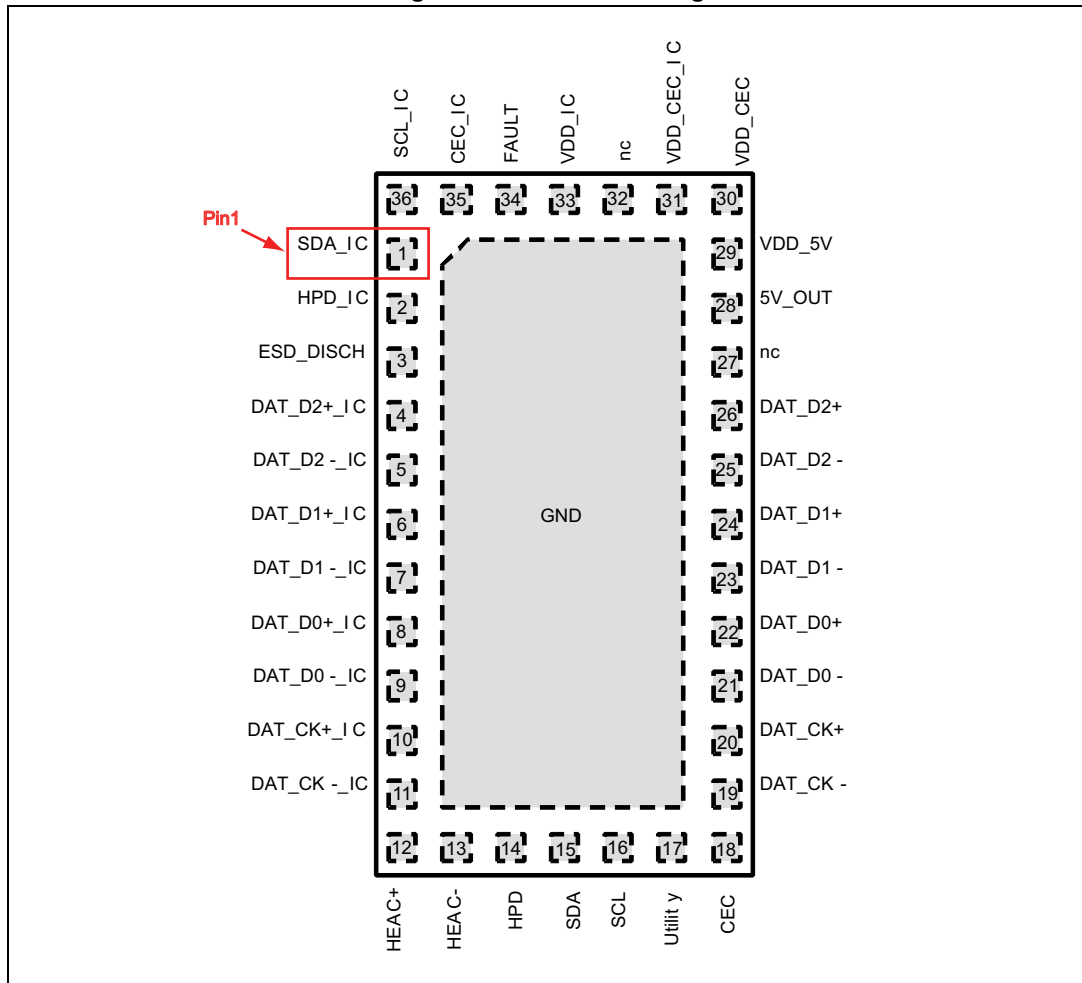

3 Electrical characteristics

Table 3. Absolute maximum ratings (limiting values)

| Symbol | Parameter | Test conditions | Value | Unit |
|--|--|-------------------|---------------|------|
| V_{pp_BUS} | ESD discharge on HDMI BUS side (pin 14 to 26, and pin 28), IEC 61000-4-2 level 4 | Contact discharge | $\pm 8^{(1)}$ | kV |
| V_{pp_IC} | ESD discharge (all pins), HBM JESD22-A114D level 2 | Contact discharge | ± 2 | kV |
| T_{stg} | Storage temperature range | | -55 to +150 | °C |
| T_{op} | Operating temperature range | | -40 to +85 | °C |
| T_L | Maximum lead temperature | | 260 | °C |
| V_{DD_5V} V_{DD_IC} V_{DD_CEC} $V_{DD_CEC_IC}$ | Supply voltages | | 6 | V |
| Inputs | Logical input min/max voltage range | | -0.3 to 6 | V |

1. With a 100 nF capacitor connected to the 5V_OUT pin.

Table 4. Power supply characteristics ($T_{amb} = 25\text{ °C}$)

| Symbol | Parameter | Test conditions | Min. | Typ. | Max. | Unit |
|------------------------|--|--|------|------|------|---------------|
| V_{DD_CEC} | CEC supply voltage, bus side | | 2.97 | 3.3 | 3.63 | V |
| $V_{DD_CEC_IC}$ | CEC supply voltage, IC side | | 1.62 | | 3.63 | V |
| V_{DD_IC} | Low-voltage ASIC supply voltage | | 1.62 | | 3.63 | V |
| V_{DD_5V} | 5 V input supply voltage range | | 4.9 | 5.0 | 5.3 | V |
| $V_{DD_5V_ON}^{(1)}$ | +5 V power on reset | | 3.5 | 3.8 | 4.1 | V |
| $V_{DD_CEC_ON}$ | CEC power on reset | | 2.6 | 2.8 | 2.95 | V |
| I_{QS_5V} | Quiescent currents on V_{DD_5V} , V_{DD_IC} , V_{DD_CEC} , $V_{DD_CEC_IC}$ | $V_{DD_5V} = 5\text{ V}$, $V_{DD_IC} = 1.8\text{ V}$, $V_{DD_CEC} = 3.3\text{ V}$ $V_{DD_CEC_IC} = 1.8\text{ V}$ Idle-state on CEC and DDC links, HPD and 5V_OUT links open | | | 600 | μA |
| I_{QS_IC} | | | | | 75 | |
| I_{QS_CEC} | | | | | 200 | |
| $I_{QS_CEC_IC}$ | | | | | 40 | |
| I_{LEAK} | Back drive current for 5V_OUT, SDA, SCL, HPD | $V_{DD_5V} = 0\text{ V}$, $V_{DD_IC} = 0\text{ V}$, tested pin = 5 V | | | 1 | μA |
| R_{th} | Junction to ambient thermal resistance | Copper heatsink as shown by Figure 28 | | 75 | | °C/W |
| T_{SD} | Thermal Shutdown threshold | | 120 | | 150 | °C |
| P_{TOTAL_SB} | Standby conditions | $V_{DD_5V} = V_{DD_IC} = 0\text{ V}$ $V_{DD_CEC} = 3.3\text{ V}$ $V_{DD_CEC_IC} = 3.3\text{ V}$ | | | 0.8 | mW |

- In order to activate the DDC functional block, the 3 following conditions have to be met:
 - V_{DD_5V} has to reach the $V_{DD_5V_ON}$ threshold
 - The inputs and outputs of the bidirectional level shifter must be set to a high level after the power-on
 - The HPD line has to be activated one time

Table 5. CEC electrical characteristics⁽¹⁾

| Symbol | Parameter | Test conditions | Min. | Typ. | Max. | Unit |
|-------------------|--|--|------|------|-------------------|---------------|
| V_{Tup_CEC} | Upward input voltage threshold on bus side | | | | 2.0 | V |
| V_{Tdown_CEC} | Downward input voltage threshold on bus side | | 0.8 | | | V |
| V_{HYST_CEC} | Input hysteresis on bus side | | | 0.4 | | V |
| T_{RISE_CEC} | Output rise-time (10% to 90%) | $R_{UP_CEC} = 14.1\text{ k}\Omega^{(2)}$ | | | 250 | μs |
| T_{FALL_CEC} | Output fall-time (90% to 10%) | $C_{CEC_CABLE} = 7.9\text{ nF}^{(2)}$ | | | 50 | μs |
| I_{OFF_CEC} | Leakage current in powered-off state | $V_{DD_5V} = 0\text{ V}$ $V_{DD_IC} = 0\text{ V}$, $V_{DD_CEC} = 3.3\text{ V}$ | | | 1.8 | μA |
| $V_{IL_CEC_IC}$ | Input low level on IC side | | 0.5 | | | V |
| $V_{IH_CEC_IC}$ | Input high level on IC side | $V_{IH_CEC_IC} = 1.8\text{ V}$ | | | 1.5 | V |
| | | $V_{IH_CEC_IC} = 3.3\text{ V}$ | | | 1.9 | |
| R_{ON_CEC} | On resistance across CEC and CEC_IC pins | CEC pin to 0 V | | | 100 | Ω |
| C_{IN_CEC} | Input capacitance on CEC link | $V_{DD_5V} = 0\text{ V}$ $V_{DD_CEC} = 0\text{ V}$ $V_{DD_IC} = 0\text{ V}$ $V_{BIAS} = 0\text{ V}$, $f = 1\text{ MHz}$, $V_{OSC} = 30\text{ mV}$ | | | 25 ⁽³⁾ | pF |

- $T_{amb} = 25\text{ }^\circ\text{C}$, $V_{DD_CEC} = 3.3\text{ V}$, $V_{DD_CEC_IC} = 1.8\text{ V}$, unless otherwise specified
- Test conditions are compliant with worst case CEC specification:
 - Correspond to two $27\text{ k}\Omega$ +5% pull-up resistances in parallel (compliant with HDMI CTS)
 - Max capacitance corresponding to 9 equipment chained on the CEC bus
- Maximum capacitance allowed at connector output is 200 pF in HDMI 1.4 specification

Table 6. 5V_out current limiter electrical characteristics⁽¹⁾

| Symbol | Parameter | Test conditions | Value | | | Unit |
|----------------|-------------------------------|-------------------------------------|-------|------|-------------------|------|
| | | | Min. | Typ. | Max. | |
| V_{DROP} | Drop-out voltage | $I_{5V_OUT} = 55\text{ mA}$ | 20 | 50 | 95 ⁽²⁾ | mV |
| I_{5V_OUT} | Output current ⁽³⁾ | $V_{5V_OUT} = 0\text{ V}$ | 55 | | 115 | mA |
| V_{L_FAULT} | Low level on FAULT pin | $R_{PU_FAULT} = 10\text{ k}\Omega$ | | | 0.3 | V |

- $T_{amb} = 25\text{ }^\circ\text{C}$, $V_{DD_5V} = 5\text{ V}$, unless otherwise specified
- HDMI 1.4 specification requires a maximum of 100 mV voltage-drop
- HDMI 1.4 standard specifies a minimal current capability of 55 mA , and an over-current protection of no more than 500 mA

Table 7. HPD, HEAC, and utility line electrical characteristics⁽¹⁾

| Symbol | Parameter | Test conditions | Value | | | Unit |
|---|--------------------------------|--|-------|------|------|------|
| | | | Min. | Typ. | Max. | |
| I _{PULL_DOWN} | Pull-down current in HPD block | | | 15 | 25 | μA |
| V _{TH_HP} | HPD input threshold | | 1.0 | | 1.7 | V |
| C _{IN_HP} C _{IN_UTILIT} Y | Input capacitance | V _{DD_5V} = 0 V, V _{BIAS} = 0 V f = 1 MHz, V _{OSC} = 30 mV | | 9 | | pF |
| f _{CUT_HEAC} | Cut-off frequency of HEAC bus | | | 500 | | MHz |

1. T_{amb} = 25°C, V_{DD_5V} = 5 V, unless otherwise specified.

Table 8. DDC bus (SDA and SCL lines) electrical characteristics⁽¹⁾

| Symbol | Parameter | Test conditions | Value | | | Unit |
|------------------------|--|---|-------|------|-------------------|---------------------|
| | | | Min. | Typ. | Max. | |
| V _{Tup_BUS} | Upward input voltage threshold on bus side | | | | 3.5 | V |
| V _{Tdown_BUS} | Downward input voltage threshold on bus side | | 1.5 | | | V |
| V _{HYST_BUS} | Input hysteresis on bus side | | 1.0 | | 1.3 | V |
| V _{OL_BUS} | Output low level | Current sunk by SDA and SCL pin is 3 mA | | | 0.35 | V |
| T _{RISE_BUS} | Output rise-time (30% to 70%) | C _{BUS} = 750 pF ⁽²⁾ R _{UP} = 2 kΩ // 47 kΩ + 10% ⁽³⁾ | | | 500 | ns |
| T _{FALL_BUS} | Output fall-time (30% to 70%) | | | | 50 | ns |
| V _{Tup_IC} | Upward input voltage threshold on IC side | | 55 | 60 | 65 | %V _{DD_IC} |
| V _{Tdown_IC} | Downward input voltage thresholds IC side | | 35 | 40 | 45 | %V _{DD_IC} |
| V _{OL_IC} | Output low level on IC side | Current sunk by SDA_IC or SCL_IC pins is 500 μA | | | 20 | %V _{DD_IC} |
| C _{IN_DDC} | Input capacitance on DDC link | V _{DD_5V} = 0 V V _{DD_IC} = 0 V V _{DD_CEC} = 0 V V _{BIAS} = 0 V, f = 1 MHz V _{OSC} = 30 mV | | 9 | 17 ⁽⁴⁾ | pF |

1. T_{amb} = 25 °C, V_{DD_5V} = 5 V, V_{DD_IC} = 1.8 V, unless otherwise specified

2. Maximum load capacitance allowed on I2C entire link (cable + connector) is 750 pF in HDMI 1.4 specification.

3. Two pull-up resistors in parallel (sink 47 kΩ + source 2 kΩ).

4. Maximum capacitance allowed at connector output is 50 pF in HDMI 1.4 specification

Table 9. TMDS links electrical characteristics⁽¹⁾

| Symbol | Parameter | Test conditions | Value | | | Unit |
|-----------------------|------------------------------------|--|-------|--------------------|------|------|
| | | | Min. | Typ. | Max. | |
| f _{CUT_TMDS} | Bandwidth at - 3dB | Single Ended mode | | 4.7 ⁽²⁾ | | GHz |
| | | Differential mode | | 6.5 ⁽²⁾ | | |
| V _{BR} | Breakdown voltage | | 6 | | | V |
| I _{RM} | Leakage current | V _{RM} = 3.3 V | | | 100 | nA |
| C _{I/O-GND} | Capacitance input/output to ground | V _{I/O} =0 V, f=1 MHz, V _{OSC} =30 mV | | | 1.5 | pF |
| V _{CL} | Clamping voltage | I _{PP} = 16 A, IEC61000-4-2, I/O to GND, ESD_DISCH = 1 μF | | 10 | | V |
| ΔC _{I/O-GND} | Capacitance variation | V _{I/O} = 0V, f=1 MHz, V _{OSC} =30 mV | | 50 | | fF |
| Z _{DIFF} | Differential impedance | tr = 200ps (10%-90%) Z _{DIFF} =100Ω | 85 | 100 | 115 | Ω |

1. Tamb =25°C, VDD_5V = 5V, unless otherwise specified
2. The bandwidth is large enough to operate up to 340 MHz as HDMI clock frequency, corresponding to 10.2 Gbps total data rate, 3.4 Gbps on each lane

Figure 16. TMDS line S₂₁ frequency curve

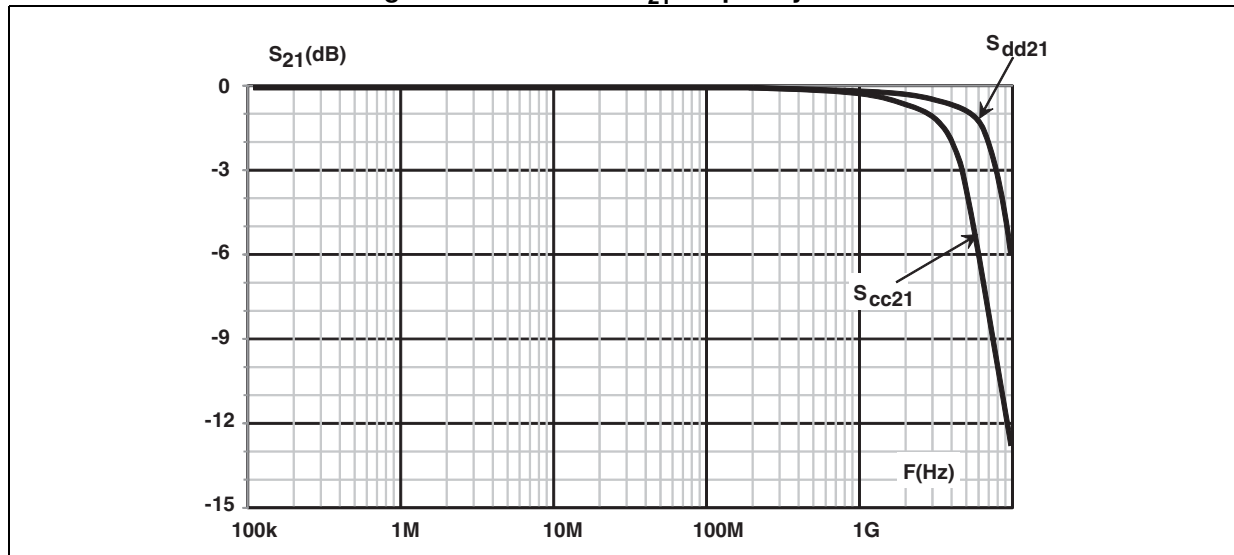

Figure 17. TMDS line differential far end crosstalk curve

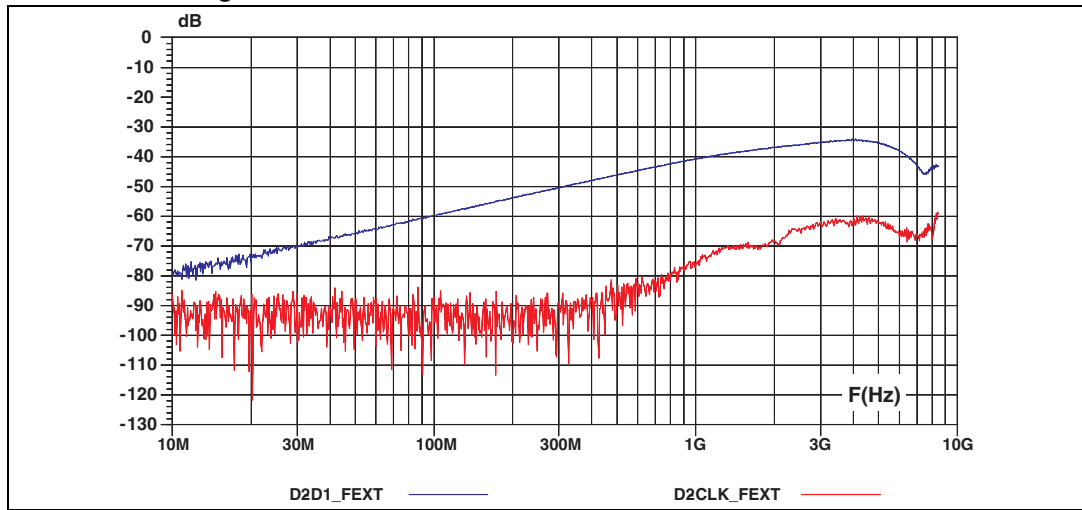

Figure 18. TMDS line: remaining voltage when positive 8 kV ESD surge applied

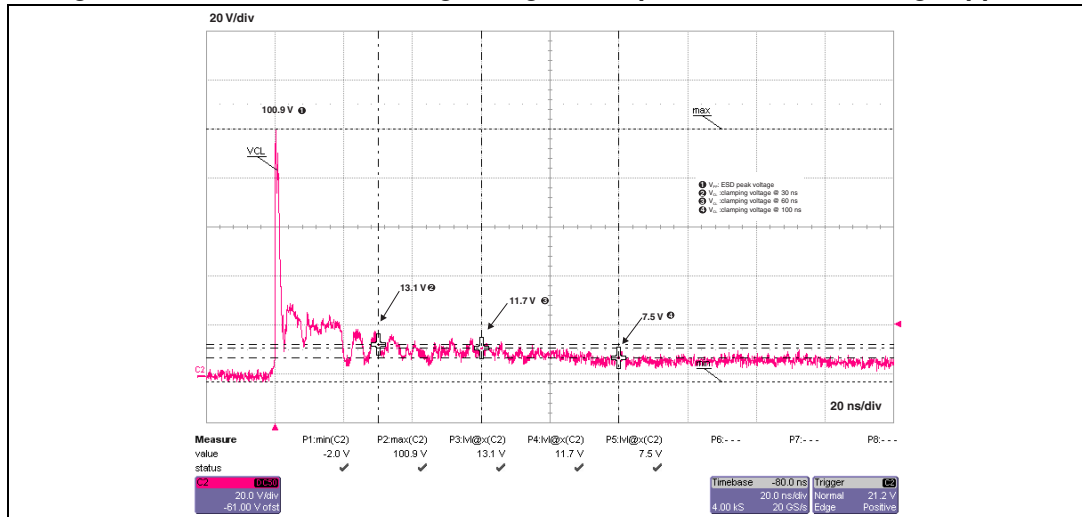

Figure 19. TMDS line: remaining voltage when negative 8 kV ESD surge applies

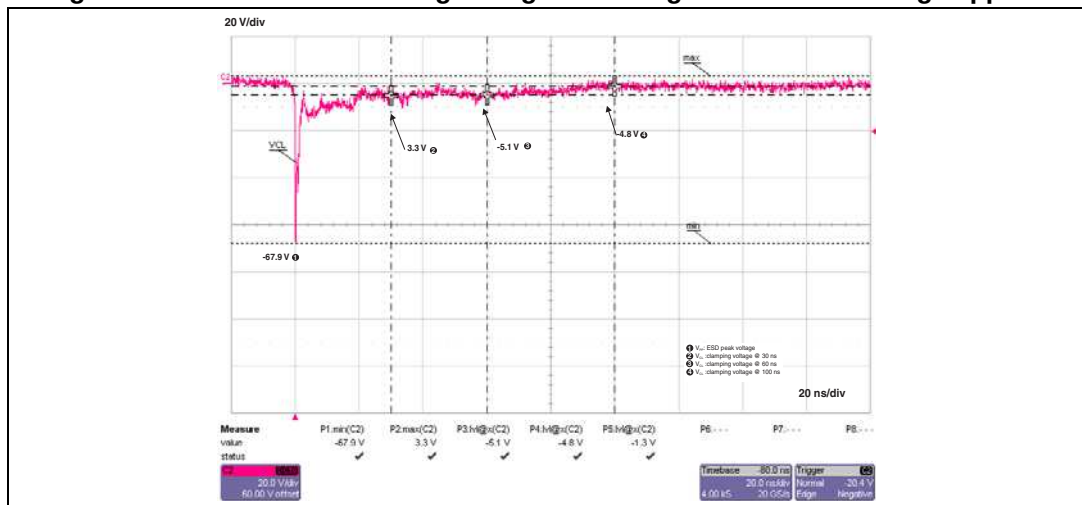

Figure 20. Eye diagram of TMDS line: D0, D1, D2 and CLK lanes (1.485 Gbps)

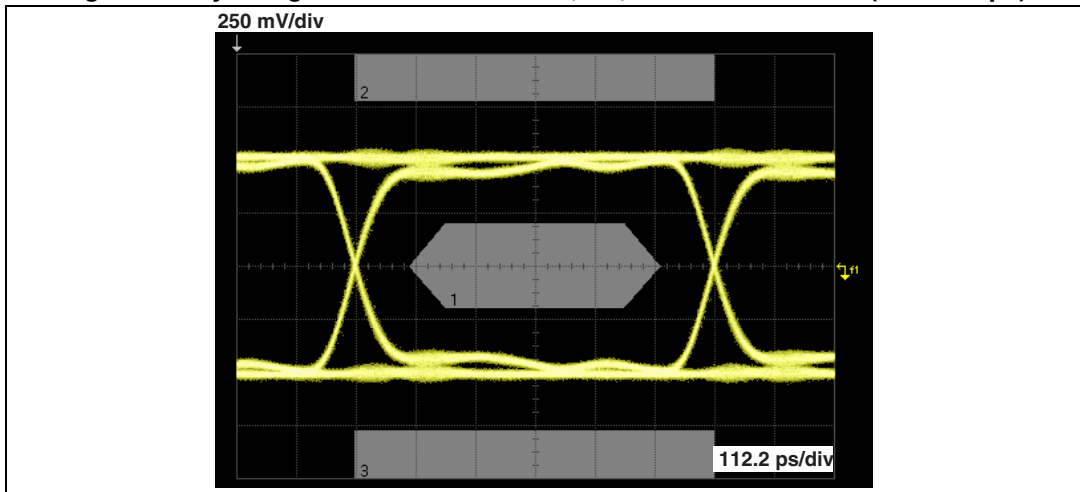

Figure 21. Eye diagram of TMDS line: D0, D1, D2 and CLK lanes (3.350 Gbps)

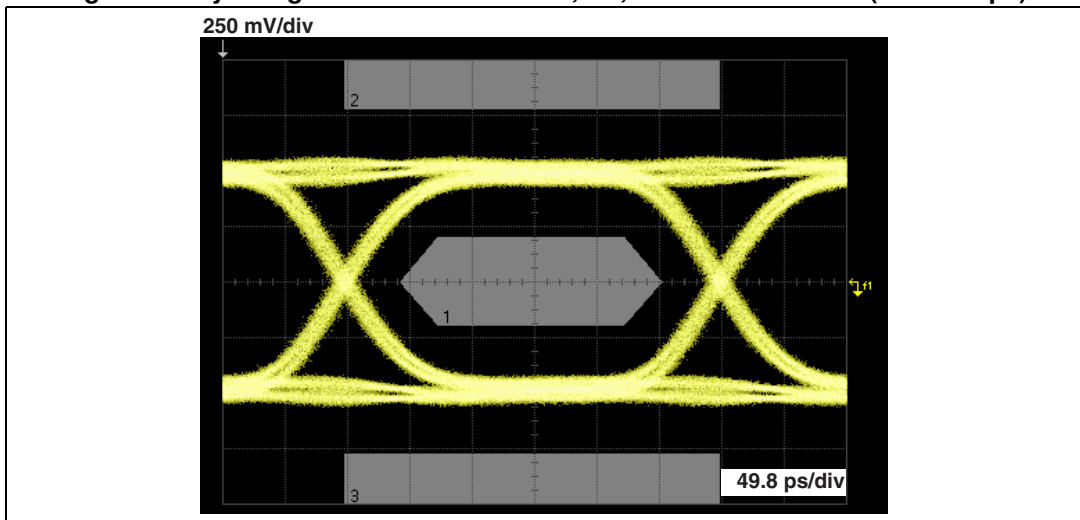

Figure 22. TDR of TMDS lines: D0, D1, D2, CLK lanes

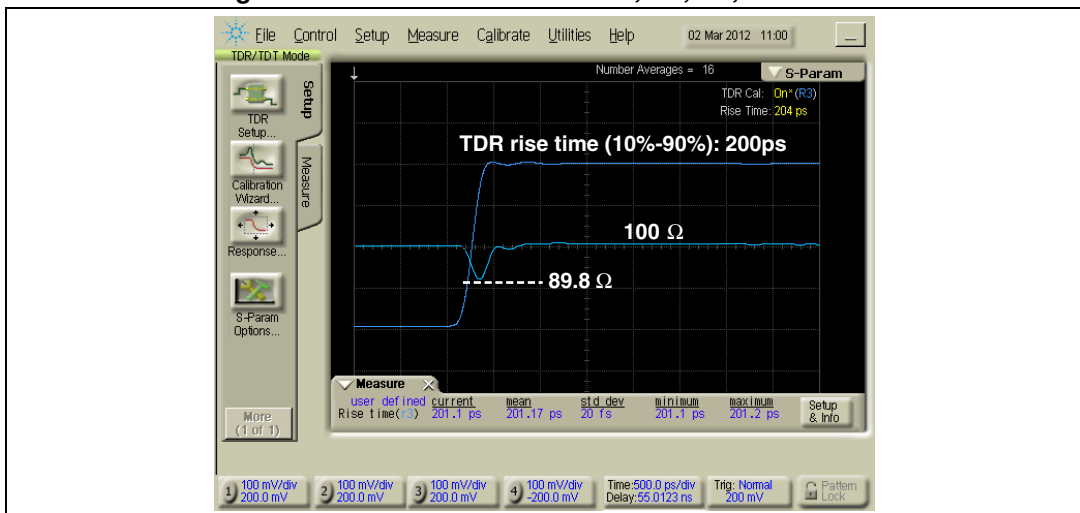

Figure 23. CEC typical waveforms (source to sink communication)

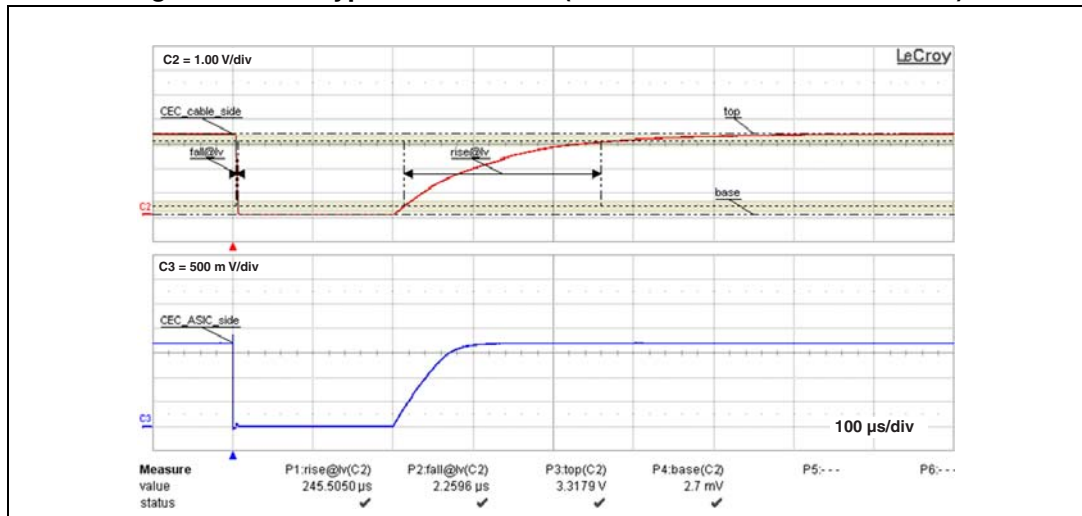

Figure 24. CEC typical waveforms (sink to source communication)

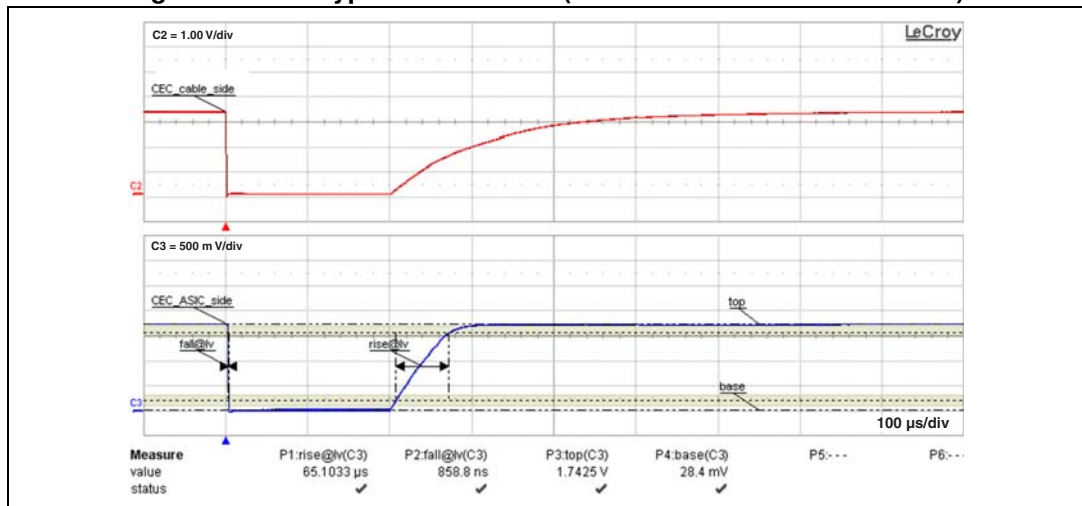

Figure 25. DDC typical waveforms (sink to source communication)

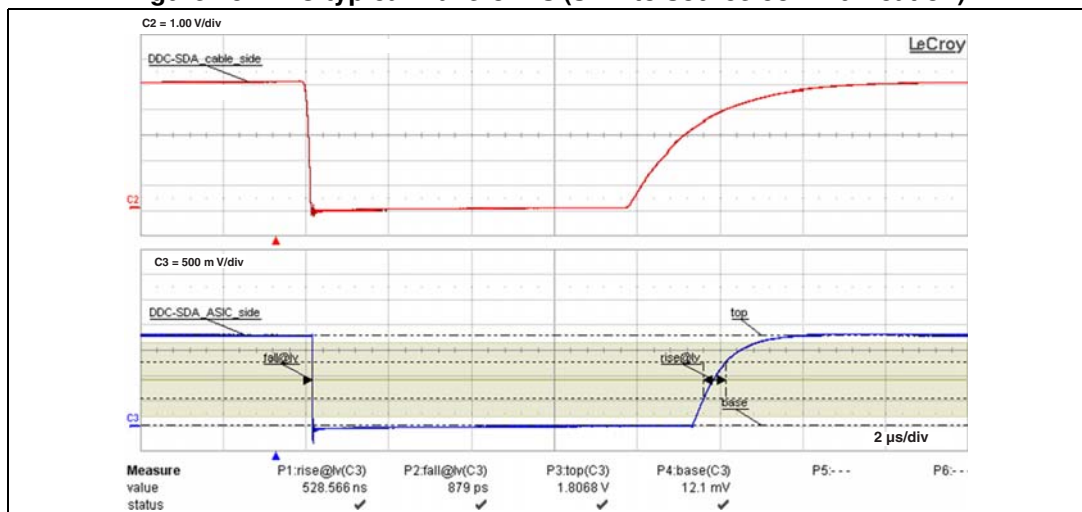

Figure 26. DDC typical waveforms (source to sink communication)

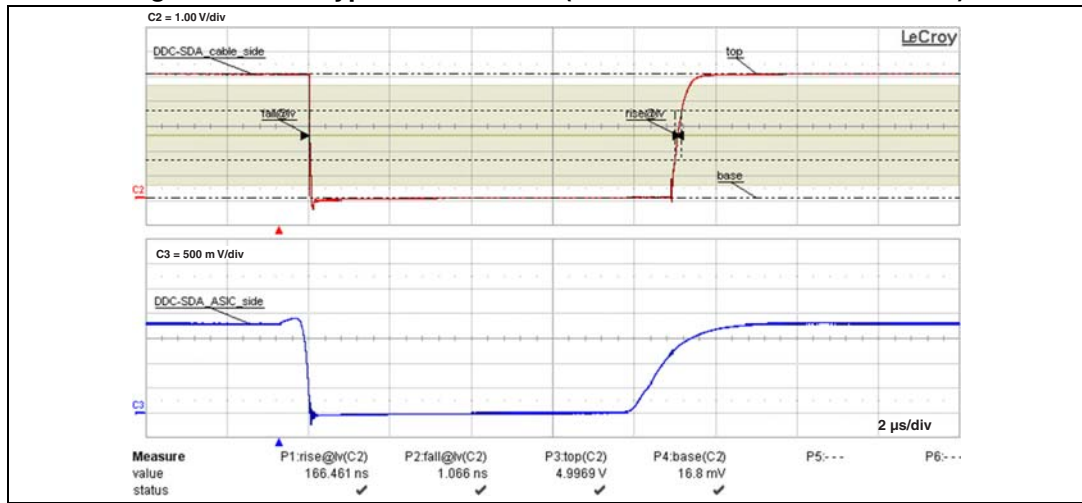

Figure 27. HPD typical waveforms (timing)

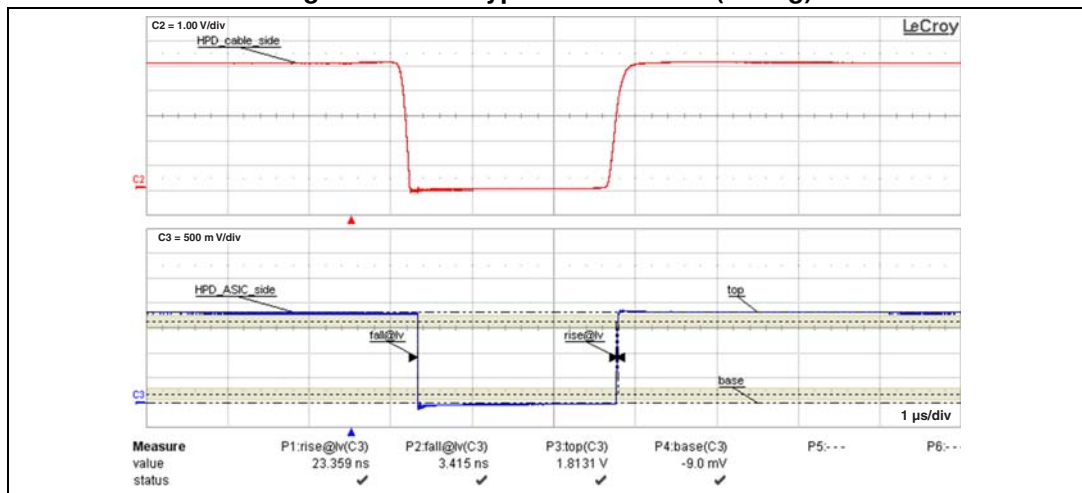

Figure 28. HEAC single ended mode typical bandwidth

