



Chipsmall Limited consists of a professional team with an average of over 10 year of expertise in the distribution of electronic components. Based in Hongkong, we have already established firm and mutual-benefit business relationships with customers from,Europe,America and south Asia,supplying obsolete and hard-to-find components to meet their specific needs.

With the principle of “Quality Parts,Customers Priority,Honest Operation,and Considerate Service”,our business mainly focus on the distribution of electronic components. Line cards we deal with include Microchip,ALPS,ROHM,Xilinx,Pulse,ON,Everlight and Freescale. Main products comprise IC,Modules,Potentiometer,IC Socket,Relay,Connector.Our parts cover such applications as commercial,industrial, and automotives areas.

We are looking forward to setting up business relationship with you and hope to provide you with the best service and solution. Let us make a better world for our industry!



Contact us

Tel: +86-755-8981 8866 Fax: +86-755-8427 6832

Email & Skype: info@chipsmall.com Web: www.chipsmall.com

Address: A1208, Overseas Decoration Building, #122 Zhenhua RD., Futian, Shenzhen, China



THIS DRAWING IS UNPUBLISHED. RELEASED FOR PUBLICATION 20
 © COPYRIGHT 20 BY - ALL RIGHTS RESERVED.

REVISIONS

P	LTR	DESCRIPTION	DATE	DWN	APVD
	A	INITIAL RELEASE	06APR2015	GY	CW
	B	ECR-15-013759	29SEP2015	DW	CW

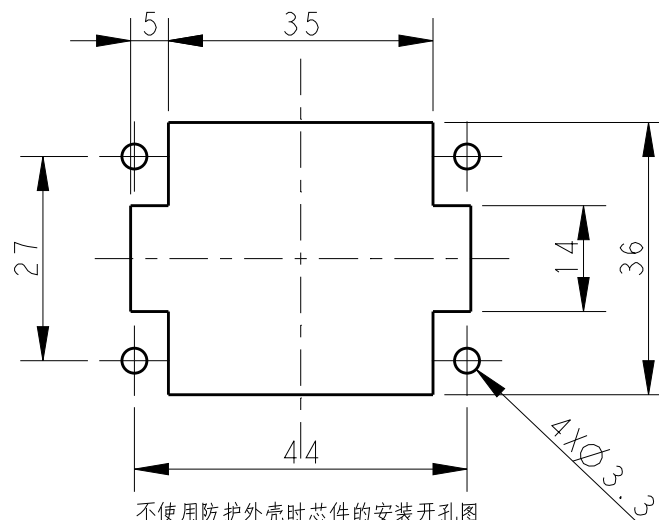
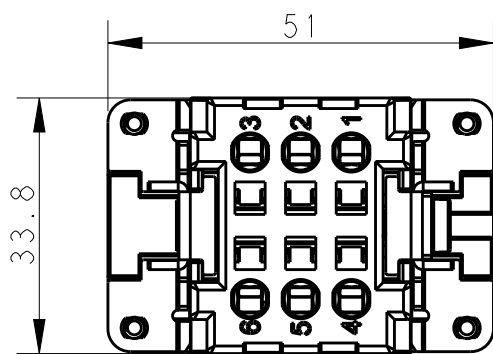

4 X M3 screw,
recommended tightening
torque 0.5Nm

不使用防护外壳时芯件的安装开孔图
 Panel cut out for inserts for
use without hoods/housings

NOTES:

- TECHNICAL CHARACTERISTICS:
 INSULATION MATERIAL: PC
 RATED VOLTAGE: 500V
 RATED CURRENT: 16A
 INSULATION RESISTANCE: $\geq 400M\Omega$
 RATED IMPULSE VOLTAGE: 6KV
 POLLUTION DEGREE: 3
 FLAMMABILITY: UL94V-0
 MATING CYCLES: 500 CYCLES
 OPERATION TEMPERATURE: $-40^{\circ}C \sim +125^{\circ}C$
 WIRE RANGE: $0.5mm^2 \sim 2.5mm^2$ (AWG20-AWG14)
 CONTACT TYPE: SPRING CLAMP

注释:

- 技术参数:
 绝缘材料: PC
 额定电压: 500V
 额定电流: 16A
 绝缘电阻: $\geq 400M\Omega$
 脉冲电压: 6KV
 污染等级: 3
 阻燃等级: UL94V-0
 插拔次数: 500 次
 工作温度: $-40^{\circ}C \sim +125^{\circ}C$
 接线范围: $0.5mm^2 \sim 2.5mm^2$ (AWG20-AWG14)
 接线类型: 弹片压接

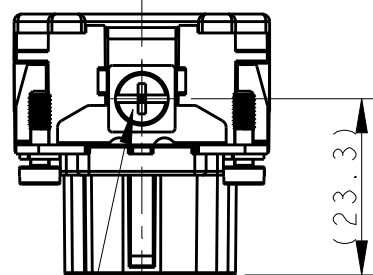
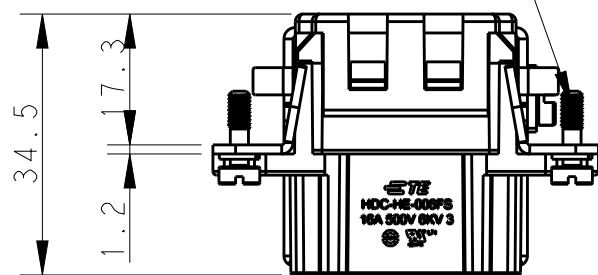

M4 screw, recommended
tightening torque 1.2Nm

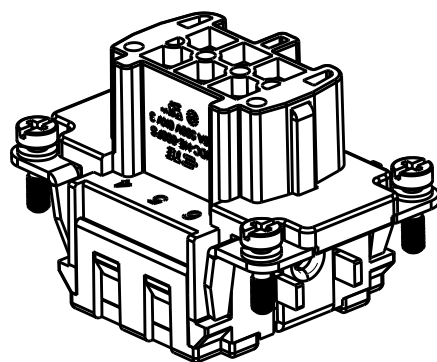
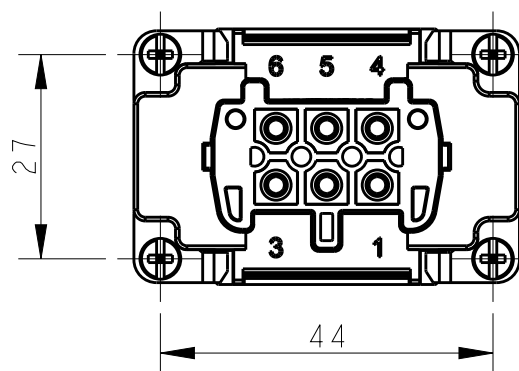

HE-006-FS	T2040063201-000
DESCRIPTION	PART NUMBER

THIS DRAWING IS A CONTROLLED DOCUMENT.		DWN	Gino.Yao	06APR2015	 TE Connectivity NAME HE-006-FS							
DIMENSIONS:		CHK	Chris.Wang	06APR2015								
mm		APVD	Xiang.Xu	06APR2015								
TOLERANCES UNLESS OTHERWISE SPECIFIED:		PRODUCT SPEC	108-137044									
0 PLC \pm 1 PLC \pm 2 PLC \pm 3 PLC \pm 4 PLC \pm ANGLES \pm		APPLICATION SPEC	114-137044		SIZE	CAGE CODE	DRAWING NO	RESTRICTED TO				
MATERIAL	FINISH	WEIGHT	-		A3	00779	©-T2040063201000	-				
-	-	-	-		Customer Drawing		SCALE	1:1	SHEET	1 OF 1	REV	B