



Chipsmall Limited consists of a professional team with an average of over 10 year of expertise in the distribution of electronic components. Based in Hongkong, we have already established firm and mutual-benefit business relationships with customers from,Europe,America and south Asia,supplying obsolete and hard-to-find components to meet their specific needs.

With the principle of “Quality Parts,Customers Priority,Honest Operation,and Considerate Service”,our business mainly focus on the distribution of electronic components. Line cards we deal with include Microchip,ALPS,ROHM,Xilinx,Pulse,ON,Everlight and Freescale. Main products comprise IC,Modules,Potentiometer,IC Socket,Relay,Connector.Our parts cover such applications as commercial,industrial, and automotives areas.

We are looking forward to setting up business relationship with you and hope to provide you with the best service and solution. Let us make a better world for our industry!



## Contact us

Tel: +86-755-8981 8866 Fax: +86-755-8427 6832

Email & Skype: info@chipsmall.com Web: www.chipsmall.com

Address: A1208, Overseas Decoration Building, #122 Zhenhua RD., Futian, Shenzhen, China



4

3

2

1

THIS DRAWING IS UNPUBLISHED.

RELEASED FOR PUBLICATION

20

© COPYRIGHT 20

BY -

ALL RIGHTS RESERVED.

REVISIONS

P	LTR	DESCRIPTION	DATE	DWN	APVD
	A	INITIAL	05JAN2015	GY	CW
	A1	ECR-15-004309	24MAR2015	GY	CW
	B	ECR-15-013759	26SEP2015	DW	CW
	B1	ECR-16-011988	27AUG2016	YC	CW

NOTES:

1. TECHNICAL CHARACTERISTICS:  
 INSULATION MATERIAL: PC  
 RATED VOLTAGE: 500V  
 RATED CURRENT: 16A  
 INSULATION RESISTANCE:  $\geq 400M\Omega$   
 RATED IMPULSE VOLTAGE: 6KV  
 POLLUTION DEGREE: 3  
 FLAMMABILITY: UL94V-0  
 MATING CYCLES: 500 CYCLES  
 WIRE RANGE:  $0.5mm^2 \sim 2.5mm^2$  (AWG20-AWG14)  
 CONTACT TYPE: SCREW CLAMP (M3)

注释:

1. 技术参数:  
 绝缘材料: PC  
 额定电压: 500V  
 额定电流: 16A  
 绝缘电阻:  $\geq 400M\Omega$   
 脉冲电压: 6KV  
 污染等级: 3  
 阻燃等级: UL94V-0  
 插拔次数: 500 次  
 接线范围:  $0.5mm^2 \sim 2.5mm^2$  (AWG20-AWG14)  
 接线类型: 螺丝压接 (M3)

24X M3 SCREW, RECOMMENDED  
 TIGHTENING TORQUE 0.5Nm  
 24X M3螺丝, 推荐锁紧力矩0.5Nm

M4 SCREW, RECOMMENDED  
 TIGHTENING TORQUE 1.2Nm  
 M4螺丝, 推荐锁紧力矩1.2Nm

4X M3 SCREW, RECOMMENDED  
 TIGHTENING TORQUE 0.5Nm  
 4X M3螺丝, 推荐锁紧力矩0.5Nm

TYPE 1, T2040242201-000, WITH LOGO  
 类型 1, T2040242201-000, 带LOGO

PANEL CUT FOR INSERTS FOR USE  
 WITHOUT HOODS/ HOUSINGS  
 不使用防护外壳时芯件的安装开孔图

THIS DRAWING IS A CONTROLLED DOCUMENT.		DWN	GINO YAO	15AUG2014	 TE Connectivity	NAME	HE-024-F							
DIMENSIONS:		CHK	CHRIS WANG	15AUG2014			PRODUCT SPEC	APPLICATION SPEC	SIZE	CAGE CODE	DRAWING NO	RESTRICTED TO		
mm		APVD	XIANG XU	15AUG2014					108-137044	114-137044	A3	00779	©-T2040242201000	-
TOLERANCES UNLESS OTHERWISE SPECIFIED:		MATERIAL		FINISH					WEIGHT	CUSTOMER DRAWING		SCALE	SHEET	OF
0 PLC ±-		-		-	-	CUSTOMER DRAWING		1:1	1	2	B1			
1 PLC ±-														
2 PLC ±-														
3 PLC ±-														
4 PLC ±-														
4 PLC ANGLES ±-														

1470-19 (3/13)

REVISIONS

P	LTR	DESCRIPTION	DATE	DWN	APVD
		SEE SHEET 1			

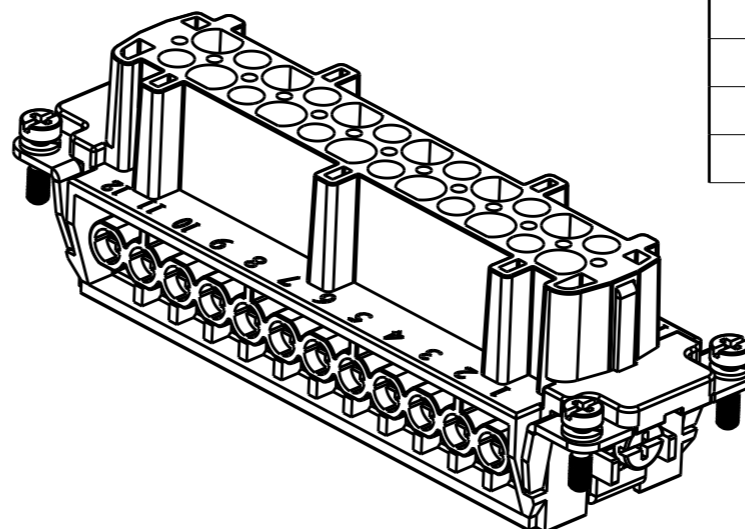
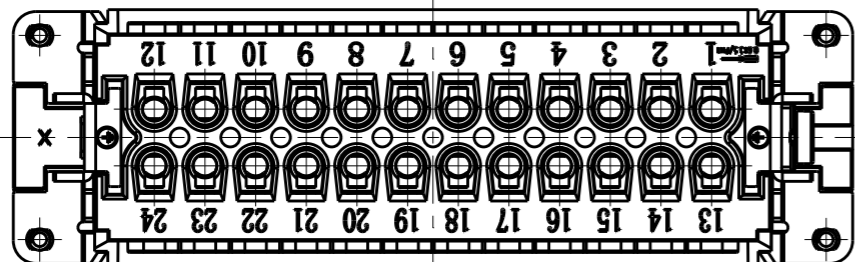

NOTE:  
ALL SPEC REFER TO TYPE 1

注释:  
所有产品规范参照 TYPE 1

TYPE 2, T2040242201-001, WITHOUT LOGO  
类型 2, T2040242201-001, 不带LOGO

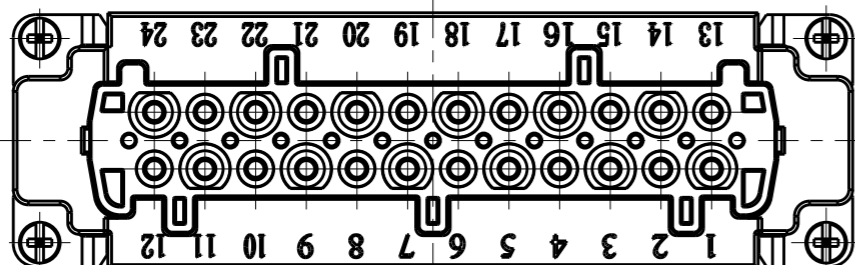
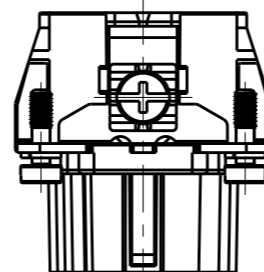
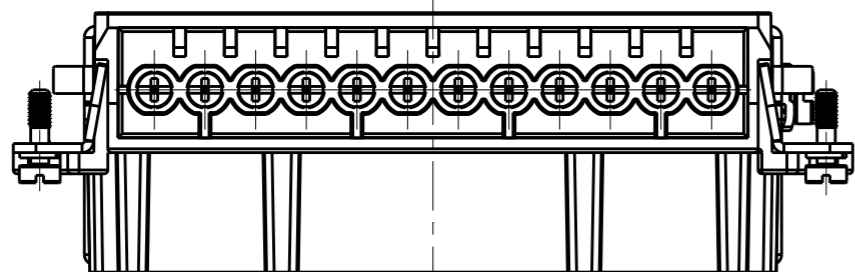

T2040242201-000	HE-024-F	HE-024 FEMALE INSERT HE-024 母插	TYPE 1
T2040242201-001	HE-024-F	HE-024 FEMALE INSERT, WITHOUT LOGO HE-024 母插, 无LOGO	TYPE 2
PART NUMBER 料号	PART DESCRIPTION 描述		TYPE 类型

THIS DRAWING IS A CONTROLLED DOCUMENT.		DWN GINO YAO 15AUG2014		
DIMENSIONS: mm		CHK CHRIS WANG 15AUG2014		
TOLERANCES UNLESS OTHERWISE SPECIFIED:		APVD XIANG XU 15AUG2014	NAME HE-024-F	
0 PLC ±-		PRODUCT SPEC 108-137044	SIZE	
1 PLC ±-		APPLICATION SPEC 114-137044	CAGE CODE	
2 PLC ±-		WEIGHT	DRAWING NO	
3 PLC ±-		CUSTOMER DRAWING	RESTRICTED TO	
4 PLC ±-			A300779	
ANGLES ±-			SCALE 1:1	
FINISH			SHEET 2 OF 2	
MATERIAL			REV B1	
			© T2040242201000	