



Chipsmall Limited consists of a professional team with an average of over 10 year of expertise in the distribution of electronic components. Based in Hongkong, we have already established firm and mutual-benefit business relationships with customers from,Europe,America and south Asia,supplying obsolete and hard-to-find components to meet their specific needs.

With the principle of "Quality Parts,Customers Priority,Honest Operation,and Considerate Service",our business mainly focus on the distribution of electronic components. Line cards we deal with include Microchip,ALPS,ROHM,Xilinx,Pulse,ON,Everlight and Freescale. Main products comprise IC,Modules,Potentiometer,IC Socket,Relay,Connector.Our parts cover such applications as commercial,industrial, and automotives areas.

We are looking forward to setting up business relationship with you and hope to provide you with the best service and solution. Let us make a better world for our industry!



Contact us

Tel: +86-755-8981 8866 Fax: +86-755-8427 6832

Email & Skype: info@chipsmall.com Web: www.chipsmall.com

Address: A1208, Overseas Decoration Building, #122 Zhenhua RD., Futian, Shenzhen, China



HEDR-54xx Series

Mid-Sized Housed Encoder



Data Sheet



Description

The HEDR-542x series are high performance, cost-effective, two-channel optional incremental housed encoders. These encoders emphasize high reliability, high resolution, and easy assembly. The HEDR-542x housed encoders use reflective technology to sense rotary position. This sensor consists of an LED light source and a photodetector IC in a single SO-8 surface mount package. The outputs of the HEDR-542x encoders are two square waves in quadrature. These encoders may be quickly and easily mounted to a motor.

Applications

The HEDR-542x provides motion detection at a low cost, making them ideal for high volume applications. Typical applications include vending machines and motor manufacturing applications.

Note: Avago Technologies encoders are not recommended for use in safety critical applications. Eg. ABS braking systems, power steering, life support systems and critical care medical equipment. Please contact sales representative if more clarification is needed.

Features

- Two channel quadrature output
- Quick and easy assembly
- Cost-effective
- Ideal for small motor systems
- -10° C to +85 °C operating temperature
- Right angle connector available
- Hub available in either a set screw configuration or a press-fit/adhesive mount configuration
- External mounting ears available

Available Styles

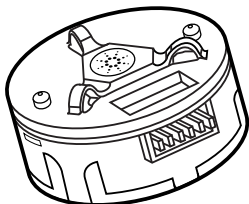

Right angle version (shown here with press fit/adhesive mount hub option)

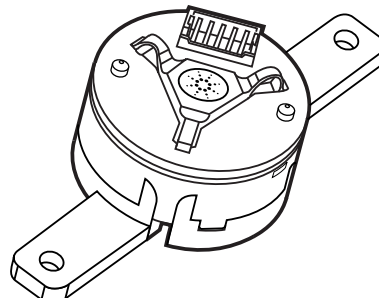

External mounting ears version (shown here with set screw type hub)

ESD WARNING: Normal Handling Precautions should be taken to avoid static discharge.

Package Dimensions

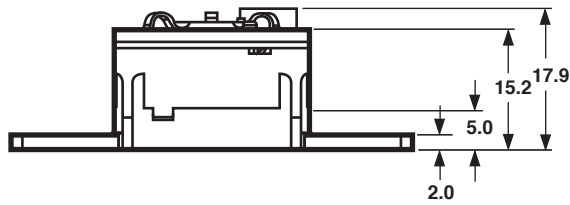
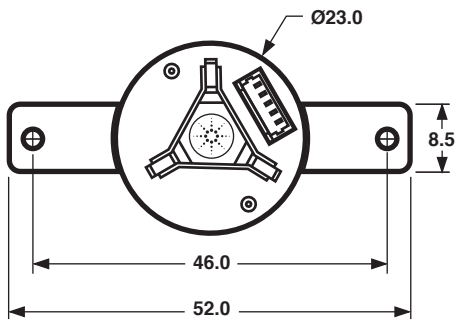
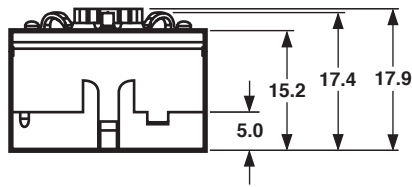
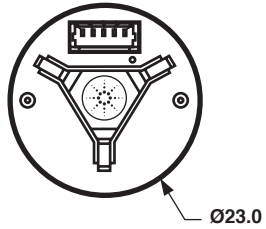
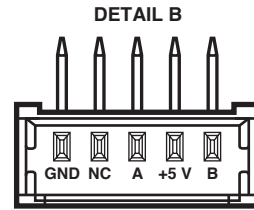
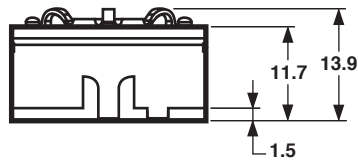
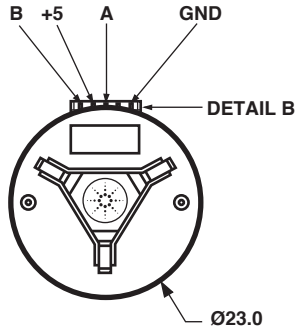
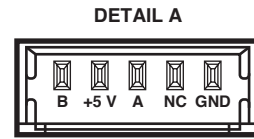
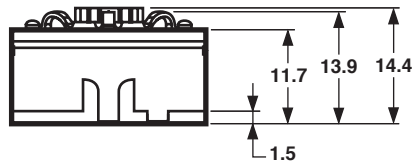
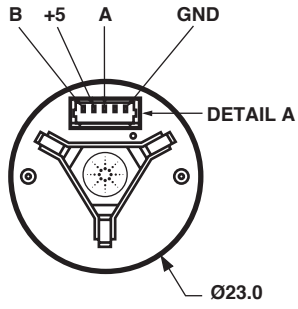

NOTE: TYPICAL DIMENSIONS IN MILLIMETERS

Theory of Operation

The HEDR-542X translates rotary motion of a shaft into a two channel digital output. As seen in the block diagram, the HEDR-542X series has three key parts: a single Light Emitting Diode (LED) light source, a photodetector IC with a set of uniquely configured photodiodes, and a pair of lenses. The lens over the LED focuses light onto the codewheel. Light is either reflected or not reflected back to the lens over the photodetector IC. As the codewheel rotates an alternating pattern of light and dark corresponding to the pattern of the codewheel falls upon the photodiodes. This light is used to produce internal signals A and A', and B and B'. As part of this "push-pull" detector system, these signals are fed through comparators that are part of the signal processing circuitry to produce the final outputs for channels A and B.

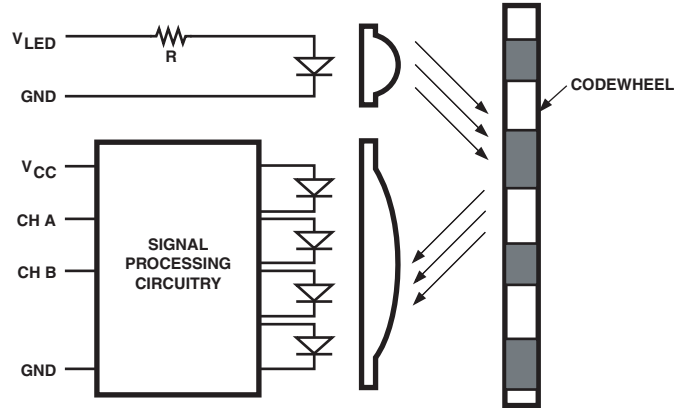

Definitions

Count (N): For rotary motion, the number of bar and window pairs or Counts Per Revolution (CPR) of the codewheel. For linear motion, the number of bar and window pairs per unit length (Lines Per Inch [LPI] or Lines Per mm [LPmm]).

One Cycle (C): 360 electrical degree ($^{\circ}$ e), 1 bar and window pair.

One Shaft Rotation: 360 mechanical degrees, N cycles (rotary motion only).

Line Density: The number of reflective and non-reflective pairs per unit length, expressed as either Lines Per Inch (LPI) or Lines Per mm (LPmm).

Pulse Width (P): The number of electrical degrees that an output is high during one cycle, nominally 180° e or $1/2$ a cycle.

Pulse Width Error (ΔP): The deviation in electrical degrees of the pulse width from its ideal value of 180° e.

State Width (S): The number of the electrical degrees between a transition in the output of the channel B. There are 4 states per cycle, each nominally 90° e.

State Width Error (ΔS): The deviation in electrical degrees of each state width from its ideal value of 90° e.

Phase (ϕ): The number of electrical degrees between the center of the high state on the channel A and the center of the high state of channel B. This value is nominally 90° e.

Phase Error ($\Delta\phi$): The deviation in electrical degrees of the phase from its ideal value of 90° e.

Output Waveforms

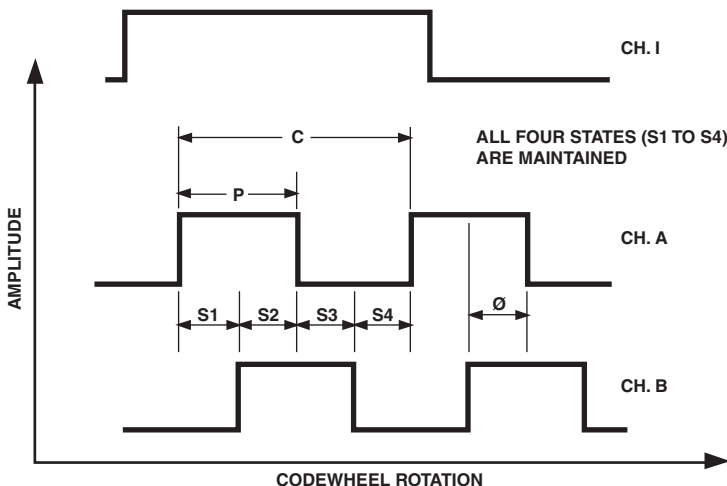

Direction of Motor Rotation

When the codewheel rotates in the clockwise direction (as viewed from the encoder end of the motor), channel A will lead channel B. If the codewheel rotates in the counterclockwise direction, channel B will lead channel A.

Absolute Maximum Ratings

Storage Temperature	-40° C to +85° C
Operating Temperature	-10°-C to +85°-C
Supply Voltage	-0.5 V to 7 V
Output Voltage	-0.5 V to V _{CC}
Output Current per Channel	-2.0 mA to 12 mA
Shaft Axial Play	± 0.25 mm
Shaft Eccentricity Plus Radial Play	0.04 mm
Radial Play between Housing and Cover	0.2 mm – 0.5 mm
Distance between Tip of Codewheel Shaft and PC Board	0.4 mm – 0.5 mm
Distance between Codewheel and Stopper before Reset	0.25 mm – 0.35 mm
Distance between Codewheel and Stopper after Reset	0.75 mm
Concentricity Misalignment between Mounted Base	0.12 mm Plate Center Bore and Motor Shaft
Frequency	16 kHz

Recommended Operating Conditions

Parameter	Symbol	Min.	Typical	Max.	Units	Notes
Temperature	T _A	0		85	°C	
Supply Voltage	V _{CC}	4.5	5.0	5.5	Volts	Ripple < 100 mV _{p-p}
LED Current	I _{LED}	13	15	18	mA	
Load Capacitance	C _L			100	pF	2.7 KΩ Pull-Up

Electrical Characteristics

(Over recommended operating conditions. Typically at 25° C)

Parameter	Symbol	Min.	Typical	Max.	Units	Notes
Supply Current	I _{CC}		18	33	mA	
High Level Output Voltage	V _{OH}	2.4			V	I _{OH} = -2 mA min.
Low Level Output Voltage	V _{OL}			0.4	V	I _{OL} = 12 mA max.

Encoding Characteristics

Parameter	Symbol	Typical	Max.	Units
Pulse Width Error	ΔP	7	75	°e
State Width Error	ΔS	15	60	°e
Phase Error	Δφ	15	60	°e
Position Error	Δθ	50	120	arcmin
Cycle Error	ΔC	10	45	°e

Mechanical Characteristics

Parameter	Dimension	Tolerance	Units
Codewheel Fits these Standard Shaft Diameters			
Press Fit/Adhesive Mount Hub	2, 3, 4	+0/-0.01	mm
Set Screw Hub	2, 3, 4, 5, (1/8)	(+0/-0.0005)	(in.)
Allowable Motor Shaft Length			
Press Fit/Adhesive Mount Hub	Between 7.5 and 8.0		mm
Set Screw Hub (uses size M1.5 Allen wrench, not included)	Between 7.5 and 11.5		
Bolt Circle Diameter (2 holes)	16 to 18		mm
Mounting Screw Size	M2 M2.5, (2-56) for external mounting ears		mm (in.)

Electrical Interface

Pull up resistors on output pins 2, 3, and 5 have already been integrated into the mid-sized encoder. Each of the three encoder outputs can drive a single TTL load in this configuration.

Connectors

The connector to be used with the mid-sized encoder is Molex Part Number 51021-0500. This is a 5 connector crimp wire to board connector.

The connector used on the encoder is orientation proof type, 2 different cables configuration required for connection to right angle and axial angle type encoder.

Pins configuration HEDR-542x series

Pin 1	GND
Pin 2	NC
Pin 3	Ch.A
Pin 4	5 V
Pin 5	Ch.B

Standard Mounting

Mounting Considerations

The mid-sized encoder must be aligned using the optional aligning pins, as specified in Figure 1, by using the optional motor boss shown in Figure 2, or by using an alignment tool or as shown in Encoder Mounting and Assembly.

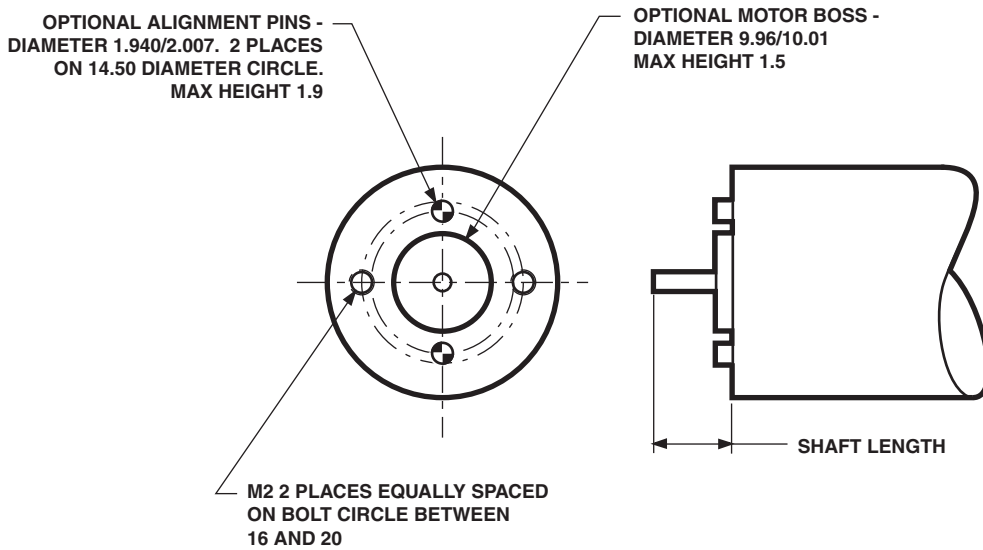

Figure 1.

Mounting with External Ears

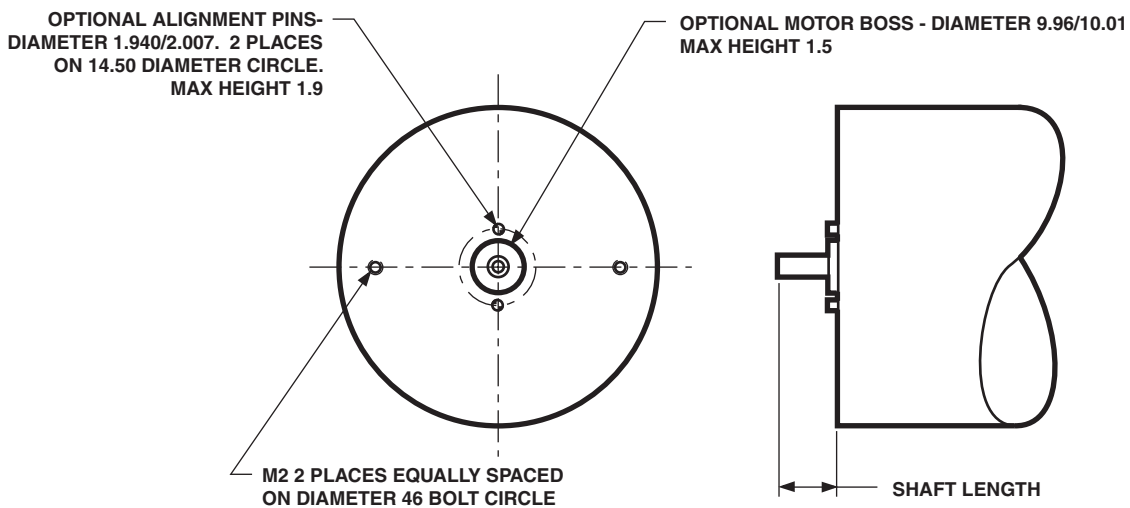
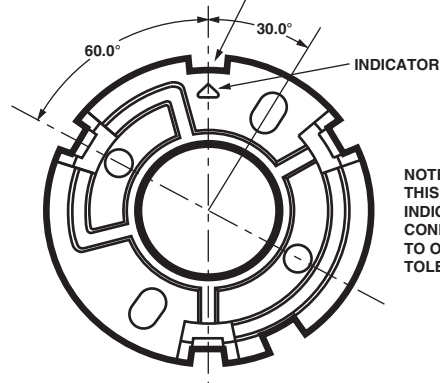
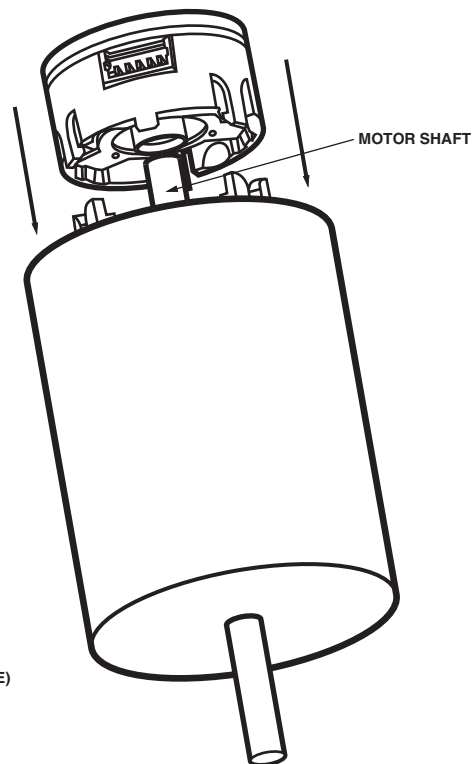
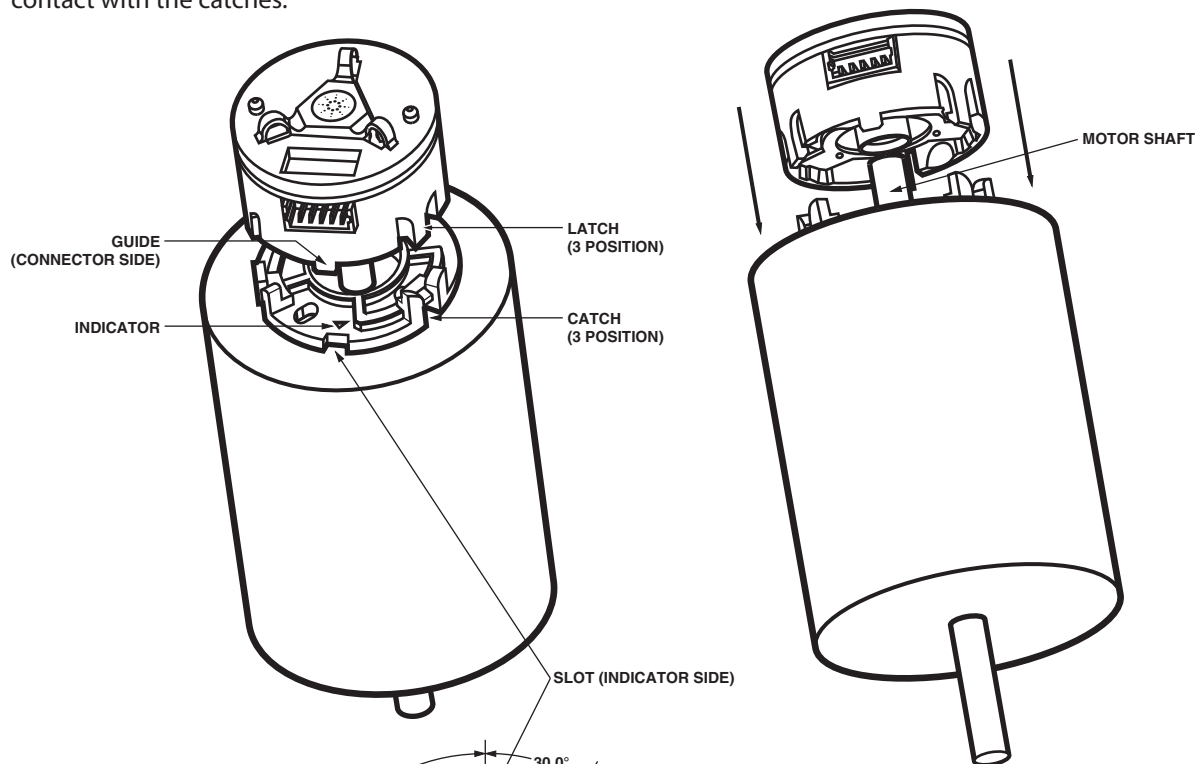
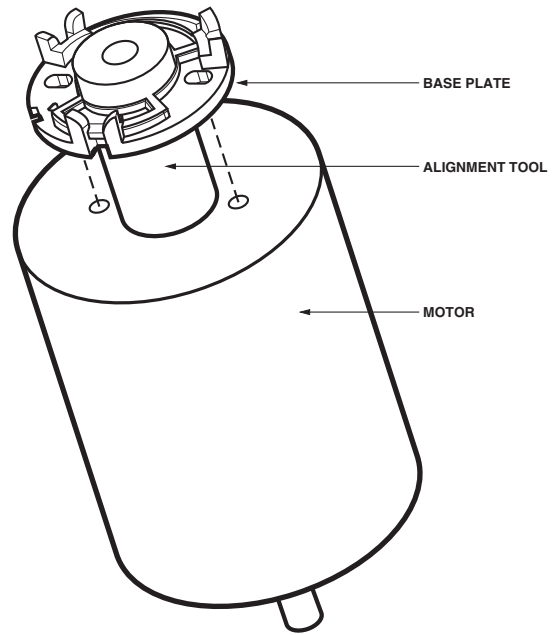

Figure 2.

Encoder Mounting and Assembly

Press Fit Style Encoder

1. If not using optional alignment pins or motor boss to locate the base plate, slip alignment tool onto motor shaft. Slip encoder base plate into place on motor as shown below. Tighten screws or attach with an adhesive. If using alignment tool, remove it.
2. Place the hub in the housing assembly on top of the motor shaft. Lining up the guide (connector side) at the bottom of the housing with the slot (indicator side) on the encoder base plate, the housing latches should be aligned to the respective baseplate catches now. Press the housing assembly downward and slide the hub into and along the shaft, until the 3 latches make contact with the catches.



NOTE:
THIS IS A TOP VIEW OF THE BASE PLATE.
INDICATOR IS ALSO INDICATING THE
CONNECTOR DIRECTION. ANGULAR OFFSET
TO OPTIONAL ALIGNMENT PIN IS 60°. TOLERANCE FOR THE ANGLE IS $\pm 2^\circ$.

3. Press down the housing assembly until it snaps into place. Recommended force is 3.5 kgf minimum, 4.0 kgf nominal, and 4.5 kgf maximum. Note that the encoder is shipped such that the housing assembly and the base plate are not being snapped together.

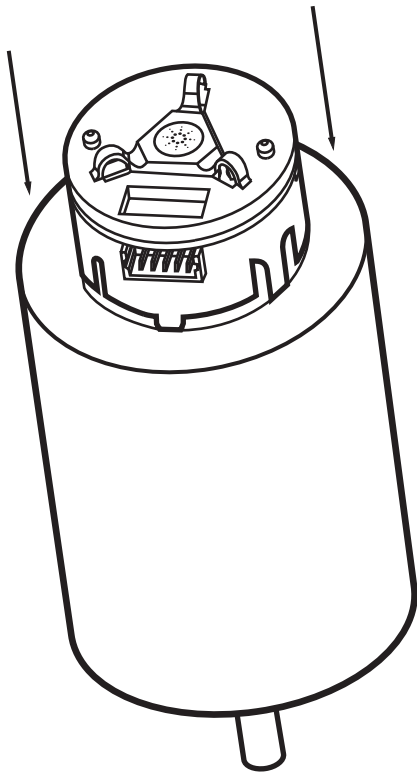

4. Using the end of a pen or other appropriate tool, press the triangular portion of the housing assembly downward. Recommended force is between 3.5 kgf to 4.0 kgf. This will set the codewheel and hub into their proper position through the internal guide of the triangular piece. When the triangular piece is released, it should naturally spring back to its original position, eliminating contact between the housing assembly and the codewheel. The encoder is now ready for use.

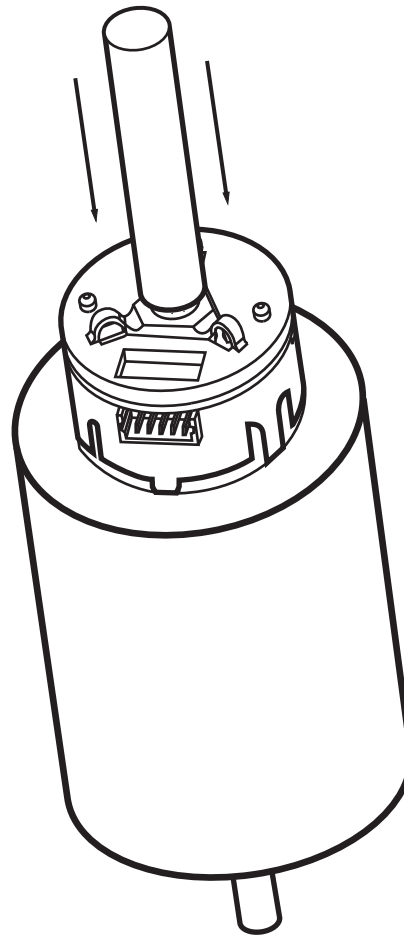

Set Screw Style Encoder

1. If not using optional alignment pins or motor boss to locate the base plate, slip alignment tool onto motor shaft. Slip encoder base plate into place on motor as shown below. Tighten screws or attach with an adhesive. If using alignment tool, remove it.

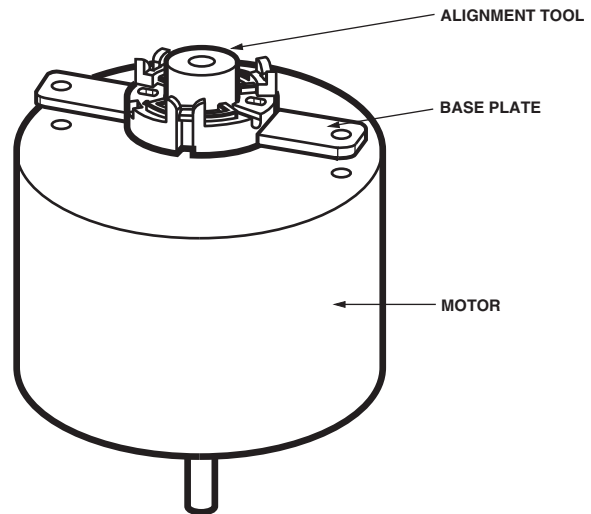

2. Slip the set screw hub into the shaft. Proper finger-wear must be worn to avoid contamination on codewheel surface (top of hub). Place an Allen wrench into the socket of the set screw while aligning it on the Allen wrench groove. Lining up the guide (connector side) at the bottom of the housing with the slot (indicator side) on the encoder baseplate, the housing latches should be aligned to the respective baseplate catches. Move the housing assembly downward until the 3 latches make contact with the catches.

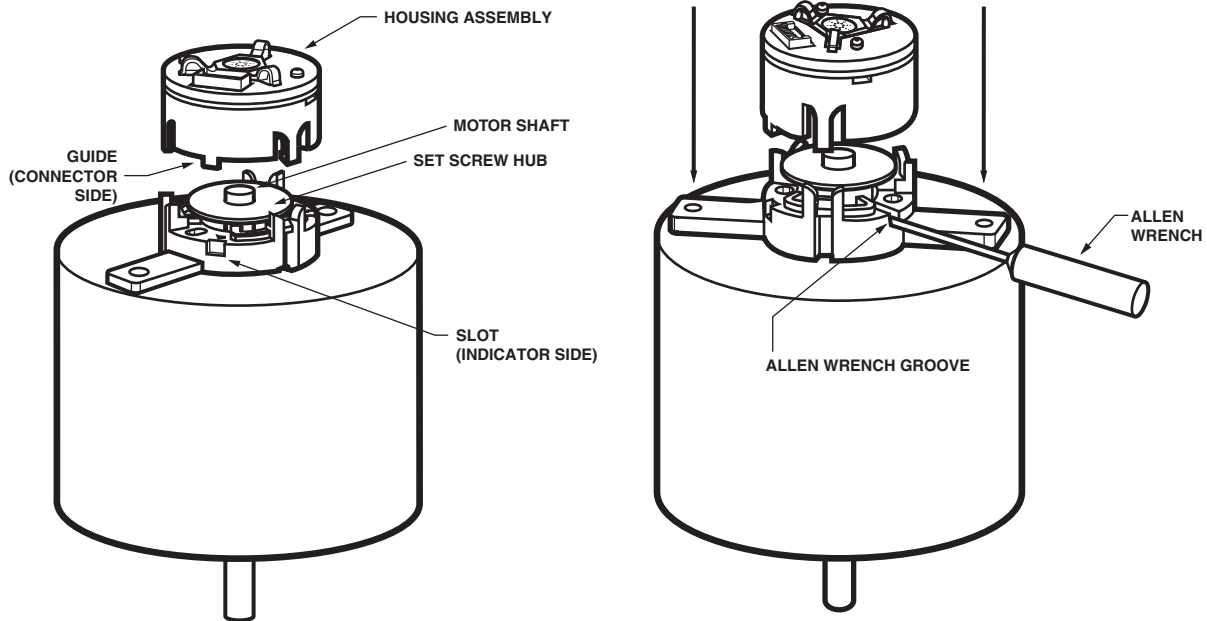

3. Press down the housing assembly, holding the set screw and Allen wrench in their initial position until the housing assembly snaps into place. Recommended force is 3.5 kgf minimum, 4.0 kgf nominal, and 4.5 kgf maximum.

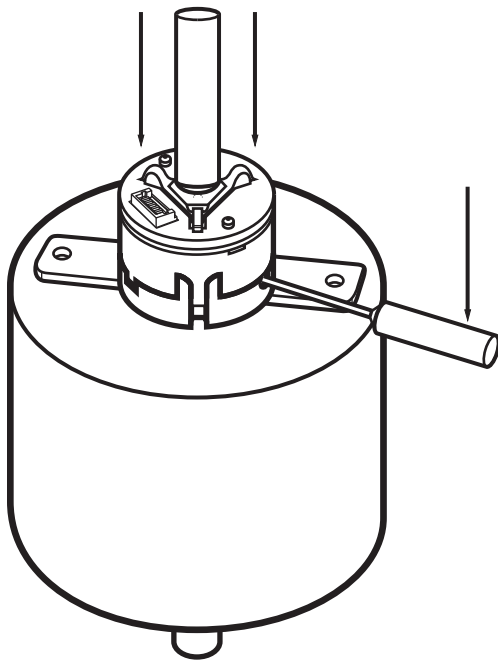
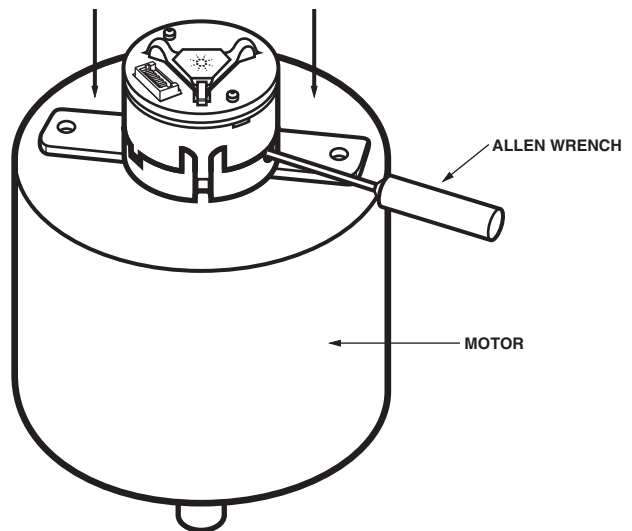

4. Using the end of a pen or other appropriate tool, press the triangular portion of the housing assembly downward. Recommended force is between 3.5 kgf to 4.0 kgf. Then apply a downward force on the end of the Allen wrench. This sets the codewheel position by levering the codewheel upward against internal guide of the triangular piece. While continuing to apply a downward force on both tools, rotate the Allen wrench in the clockwise direction until the hub set screw is tightened against the motor shaft. Remove the Allen wrench by pulling it straight out of the housing assembly. When the triangular piece is released, it should naturally spring back to its original position, eliminating contact between the housing assembly and the codewheel. The encoder is now ready for use.

Ordering Information

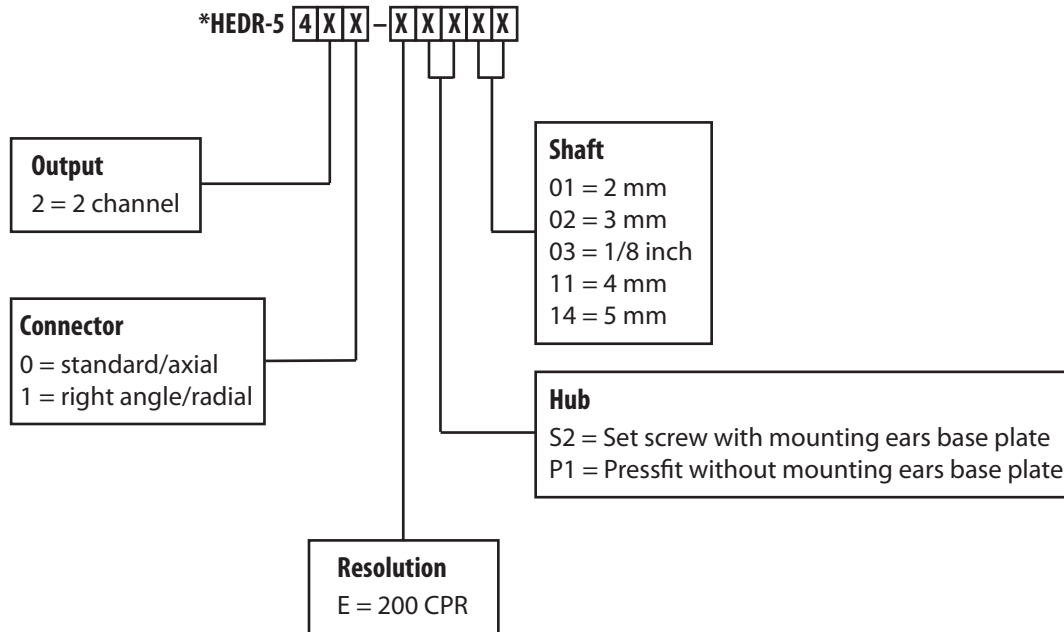

*Note: Part numbers currently available:

- a. HEDR-5420-ES201
- b. HEDR-5420-ES202
- c. HEDR-5420-ES203
- d. HEDR-5420-ES211
- e. HEDR-5420-ES214
- f. HEDR-5421-EP111

Ordering Information for Alignment Tool

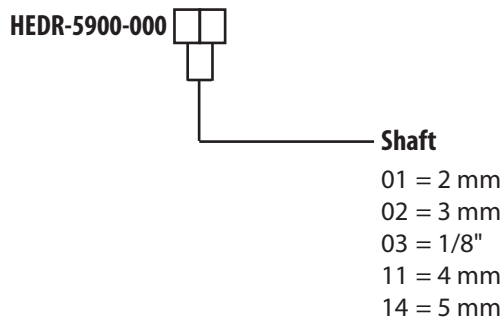

For product information and a complete list of distributors, please go to our web site: www.avagotech.com

Avago, Avago Technologies, and the A logo are trademarks of Avago Technologies in the United States and other countries. Data subject to change. Copyright © 2005-2012 Avago Technologies. All rights reserved. Obsoletes 5988-9450EN AV02-3576EN - August 7, 2012

Avago
TECHNOLOGIES