



Chipsmall Limited consists of a professional team with an average of over 10 year of expertise in the distribution of electronic components. Based in Hongkong, we have already established firm and mutual-benefit business relationships with customers from,Europe,America and south Asia,supplying obsolete and hard-to-find components to meet their specific needs.

With the principle of "Quality Parts,Customers Priority,Honest Operation,and Considerate Service",our business mainly focus on the distribution of electronic components. Line cards we deal with include Microchip,ALPS,ROHM,Xilinx,Pulse,ON,Everlight and Freescale. Main products comprise IC,Modules,Potentiometer,IC Socket,Relay,Connector.Our parts cover such applications as commercial,industrial, and automotives areas.

We are looking forward to setting up business relationship with you and hope to provide you with the best service and solution. Let us make a better world for our industry!



Contact us

Tel: +86-755-8981 8866 Fax: +86-755-8427 6832

Email & Skype: info@chipsmall.com Web: www.chipsmall.com

Address: A1208, Overseas Decoration Building, #122 Zhenhua RD., Futian, Shenzhen, China



AEDx-8xxx-xxx

2- or 3-Channel Incremental Encoder Kit with Codewheel



Data Sheet



Description

The AEDx-8xxx comes in an option of two-channel or three-channel optical incremental encoder kit with code-wheel integrated in a protective housing. The encoder is lead free and compliant to the RoHS directive. Each encoder kit consists of a collimated LED source and a detector IC enclosed within a small plastic package.

The AEDx-8xxx optical encoder has two-channel quadrature outputs (A,B) plus a third channel index output (I). There are three index options available. i.e. ungated, gated-90° and gated-180° electrical degree index pulse.

The AEDx-8xxx series optical encoder is designed for use with motors with shaft diameters of 2mm and up to 5mm. The quadrature, index and power supplied to the encoder are accessed through an 8-pin male connector of 1.25 mm pitch.

The AEDx-8xxx solution enables the servo system to be more compact. With the aid of alignment jig, the assembly process will also require less alignment time, thus making the assembly process much easier for servo motor integration.

Applications

The AEDx-8xxx provides motion detection for DC servo motor and closed loop stepper motor feedback system in the following applications:

- Pick and Place machines
- Semiconductor equipment
- Factory automation equipment

Features

- 3-channel differential output (A,B) with ungated, gated-90° and gated-180° index pulse (I)
- 2-channel differential output available
- Up to 500 Cycles Per Revolution (CPR)
- Up to 30000 rpm motor speed
- -40 °C to 100 °C operating temperature
- Single 5 V supply
- Integrated RS-422 line driver
- Quick and easy assembly

Assembly View

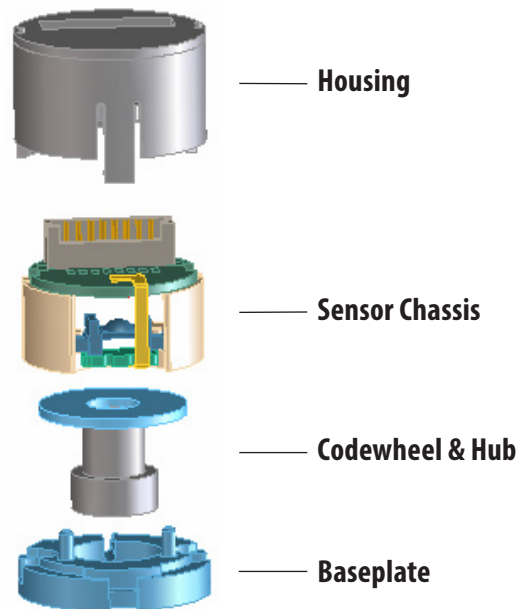

Note: Avago Technologies encoders are not recommended for use in safety critical applications, e.g., ABS braking systems, power steering, life support systems and critical care medical equipment. Avago's products and software are not specifically designed, manufactured or authorized for sale as parts, components or assemblies for the planning, construction, maintenance or direct operation of a nuclear facility or for use in medical devices or applications. Customers are solely responsible, and waive all rights to make claims against Avago or its suppliers, for all losses, damage, expense or liability in connection with such use. Please contact your local sales representative if more clarification is needed.

Theory of Operation

The AEDx-8xxx optical encoder is a housed solution with integrated encoder and codewheel. The encoder translates the rotary motion of a shaft into incremental digital outputs.

The encoder contains a single Light Emitting Diode (LED) as the light source. The light is collimated into a parallel beam by means of polycarbonate lens located directly over the LED. Opposite the emitter is a detector IC. This IC consists of multiple sets of photo detectors and signal processing circuitry necessary to produce the digital waveform output. The codewheel rotates between the emitter and detector, causing the light beam to be interrupted by pattern of spaces and bars on the codewheel. The Photodiodes that detect these interruptions are arranged in a pattern that corresponds to the radius and design of the codewheel. These detectors are also spaced in such way that light period on one pair of detectors corresponds to dark period on adjacent pair of detectors. The photodiode outputs are then fed through the signal processing circuitry that produce the final outputs for channel A and B. Due to this integrated phasing technique, the digital output of channel A is in quadrature with that of channel B (90 electrical degrees out of phase). As a standard, the outputs are fed through a standard RS422 line driver to deliver the differentials signals at the final encoder output.

Definitions

Cycles (N): The number of electrical cycles per revolution (CPR).

Note: CPR refers to the raw signal from encoder, that is the cycles before 4x decode.

One Cycle: 360 electrical degrees (°e).

One Shaft Rotation: 360 mechanical degrees.

Cycle Error (ΔC): An indication of cycle uniformity. The difference between an observed shaft angle which gives rise to one electrical cycle, and the nominal angular increment of 1/N of a revolution.

Pulse Width (P): The number of electrical degrees that an output is high during 1 cycle. This value is nominally 180°e or 1/2 cycle.

Pulse Width Error (ΔP): The deviation, in electrical degrees, of the pulse width from its ideal value of 180°e.

State Width (S): The numbers of electrical degrees between transitions in the output of channel A and the neighboring transition in the output of channel B. There are 4 states per cycle, each nominally 90°e.

State Width Error (ΔS): The deviation, in electrical degrees, of each state width from its ideal value of 90°e.

Phase (Φ): The numbers of electrical degrees between the center of the high state of channel A and the center of the high state of channel B. This value is nominally 90°e for quadrature output.

Phase Error (Δφ): The deviation of the phase from its ideal value of 90°e.

Index Pulse Width (Po): The number of electrical degrees that an index is high with reference to channel A or channel B during one full shaft rotation.

Absolute Maximum Ratings [1,2]

Parameter	Symbol	Min.	Max.	Units
1. Storage Temperature AEDS Series	T _S	-20	85	°C
Storage Temperature AEDT Series	T _S	-40	100	°C
2. Supply Voltage	V _{CC}	-0.5	7	V
3. Output Voltage	V _{OUT}	-0.5	V _{CC}	V
4. Output Current per Channel	I _{OUT}	-	± 150	mA
5. Shaft Axial Play		-	± 0.100	mm
6. Shaft Radial Play Plus Eccentricity		-	± 0.080	mm

Note:

1. Absolute Maximum Ratings are those values beyond which the safety of the device cannot be guaranteed. They are not meant to imply that the device should be operated at these limits.
2. Stresses greater than those listed under Absolute Maximum Ratings may cause permanent damage to the device. Exposure to absolute maximum rating conditions for extended periods may affect reliability.

Recommended Operating Conditions

Parameter	Symbol	Min.	Typ.	Max.	Units	Notes
1. Operating Temperature AEDS Series	T _A	-20	-	85	°C	
Operating Temperature AEDT Series	T _A	-40	-	100	°C	
2. Supply Voltage	V _{CC}	4.5	5.0	5.5	V	
3. Output frequency (200 CPR)	f	-	-	100	kHz	Velocity(rpm) x N/60
4. Output frequency (400 & 500 CPR)		-	-	200		

Encoding Characteristics (V_{CC} = 4.5 to 5.5V, T_{amb} = -40 to +100°C)

AEDx-8xxx-Exx (200 CPR only)

Parameter	Symbol	Min.	Typ. ^[3]	Max	Units	Notes
1. Pulse Width Error	ΔP	-	5	35	°e	
2. State Width Error	ΔS	-	3	35	°e	
3. Phase Error	Δφ	-	2	20	°e	
4. Cycle Error	ΔC	-	5	15	°e	
5. Index Pulse Width Un-gated	P _o	220	360	500	°e	
Index Pulse Width Gated 90°e	P _o	60	90	120	°e	
Index Pulse Width Gated 180°e	P _o	140	180	220	°e	
6. Position Error	ΔΘ	-	15	50	min. of arc	

Note 3: Typical values specified at V_{CC} = 5.0V and 25°C

Encoding Characteristics (V_{CC} = 4.5 to 5.5V, T_{amb} = -40 to +100°C)

AEDx-8xxx-xxx (400 & 500CPR)

Parameter	Symbol	Min.	Typ. ^[3]	Max	Units	Notes
1. Pulse Width Error	ΔP	-	7	60	°e	
2. State Width Error	ΔS	-	5	60	°e	
3. Phase Error	Δφ	-	2	35	°e	
4. Cycle Error	ΔC	-	7	30	°e	
5. Index Pulse Width Un-gated	P _o	220	360	500	°e	
Index Pulse Width Gated 90°e	P _o	50	90	130	°e	
Index Pulse Width Gated 180°e	P _o	135	180	225	°e	
6. Position Error	ΔΘ	-	20	60	min. of arc	

Note 3: Typical values specified at V_{CC} = 5.0V and 25°C

Electrical Characteristics (V_{CC} = 4.5 to 5.5V, T_{amb} = -40 to +100°C)

Parameter	Symbol	Min.	Typ. ^[1]	Max	Units	Notes
1. Supply Current	I _{CC}	-	50	60	mA	
2. Output High Level	V _{OH}	2.5	3.4	-	V	I _o = -20mA
3. Output Low Level	V _{OL}	-	0.3	0.5	V	I _o = 20mA
4. Output Current	I _O	-	25	40	mA	
5. Rise time	t _r	-	30	100	ns	
6. Fall time	t _f	-	30	100	ns	

Note:

1. Typical values specified at V_{CC} = 5.0V and 25°C.

Pin Assignments

Pin	Signal	Description
Pin 1	GND	Ground
Pin 2	A+	Digital Output
Pin 3	A-	Digital Output
Pin 4	B+	Digital Output
Pin 5	B-	Digital Output
Pin 6	I+	Digital Output
Pin 7	I-	Digital Output
Pin 8	Vcc	Voltage Input

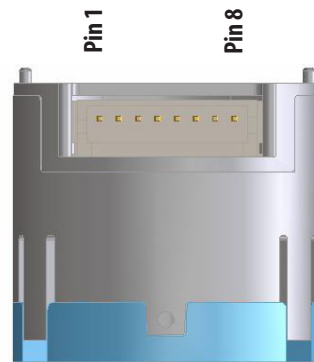

Output Waveforms

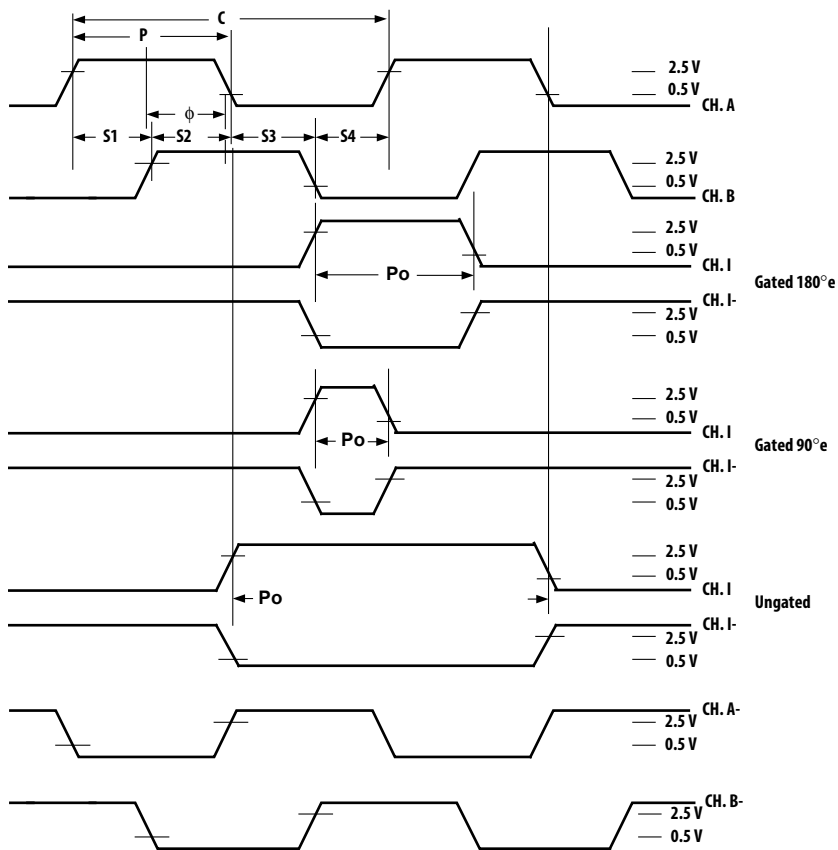
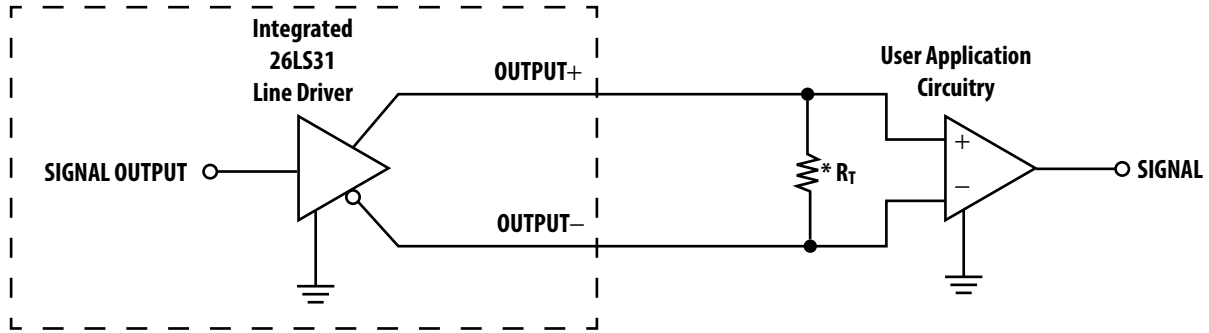

Figure 1. Output waveforms for counter-clockwise rotation, viewed from the top of the encoder.

Direction of Motor Rotation

Direction of Rotation: When the codewheel rotates in the counter-clockwise direction viewing from the top of the encoder kit, channel A will lead channel B. If the codewheel rotates in the opposite direction, channel B will lead channel A.

Electrical Interface



Note:

OUTPUT+ represents A+, B+, or I+ digital output from the encoder.

OUTPUT- represents A-, B-, or I- digital output from the encoder.

Load resistance R_T is optional although highly recommended to reduce reflection.

Package Dimensions

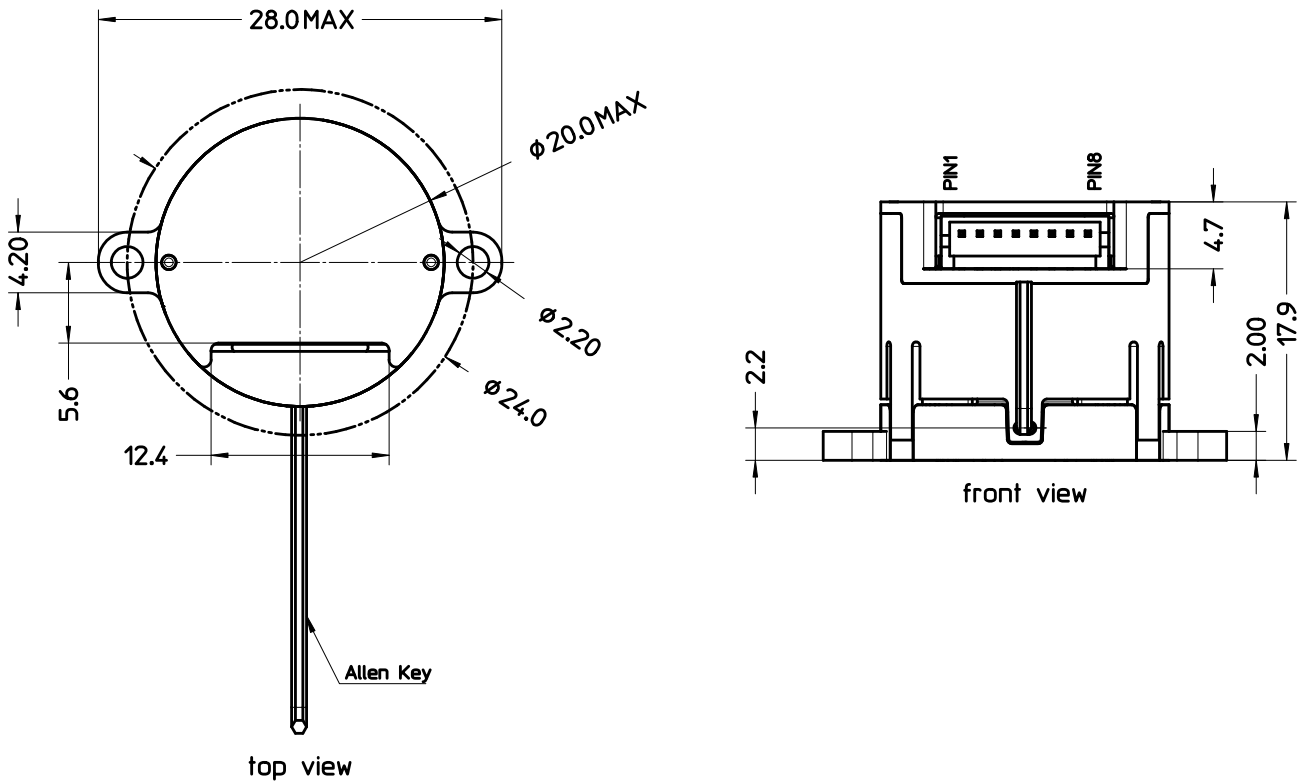

Dimensions in mm unless otherwise stated.

Tolerance: ± 0.1 mm

Figure 2. Mechanical Dimensions for Mounting Option 1 (AEDx-8x0x)

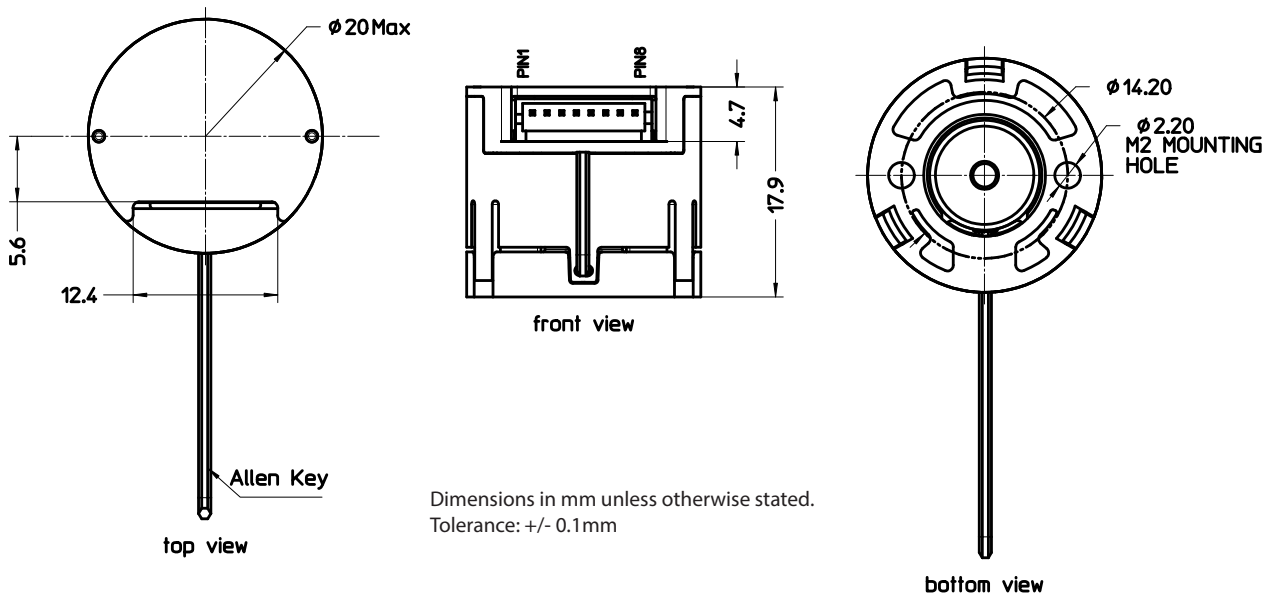
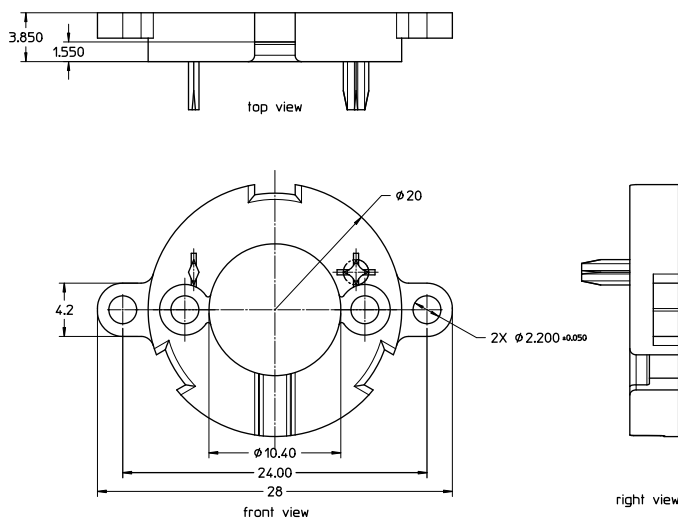

Figure 3. Mechanical Dimensions for Mounting Option 2 (AEDx-8x1x)

Mounting Considerations

Option 1 (AEDx-8x0x) with Protruded External Mounting Ear Hole



Option 2 (AEDx-8x1x) with Internal Mounting Hole

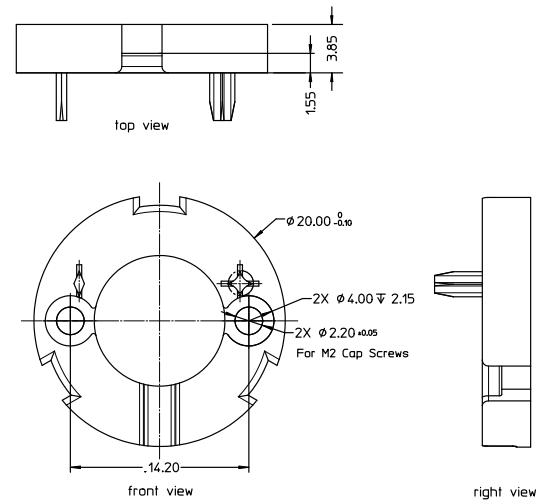

CAUTION: For optimal performance, base plate and plastic housing assembly are designed for a ONE time assembly process only. Removal and re-assembly process should be avoided due to the potential weakness of the latch after re-assembly.

Mounting Alignment Tool

Alignment Tool for AEDX-8XXX,4mm (HEDS-8938-011)

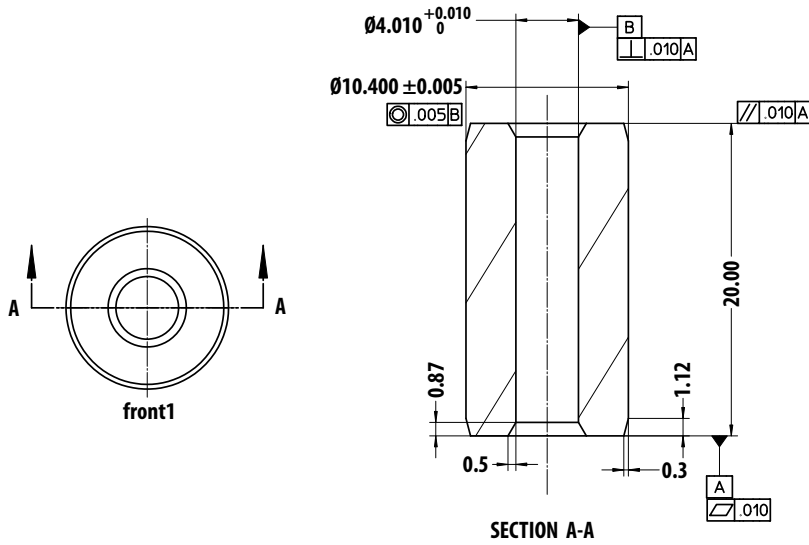

Alignment Tool for AEDX-8XXX,5mm(HEDS-8938-014)

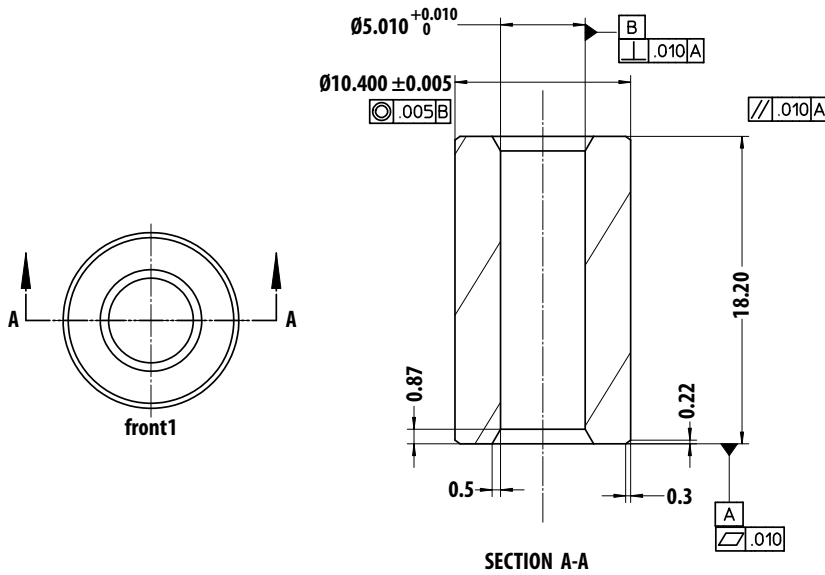

Mechanical Characteristics

Parameter	Dimension	Tolerance	Units	Notes
1. Shaft Diameter Tolerance	2, 3, 4, 5	0 -0.008	mm	
2. Recommended Shaft Length	5 to 10	N/A	mm	
3. Mounting Screw Size	2 X M2	N/A	mm	
4. Recommended Screw Torque	0.6	N/A	lb. inch	
5. Encoder Base Plate Thickness	3.85	±0.1	mm	

Recommended Mating Connectors

Temperature Option	Manufacturer	Part Number	Description
AEDS Series	Molex	53261-0871	Connector Box Type, 8-pin, 1.25mm pitch
AEDT Series	Hirose	DF13A-8P-1.25H	Connector Box Type, 8-pin, 1.25mm pitch

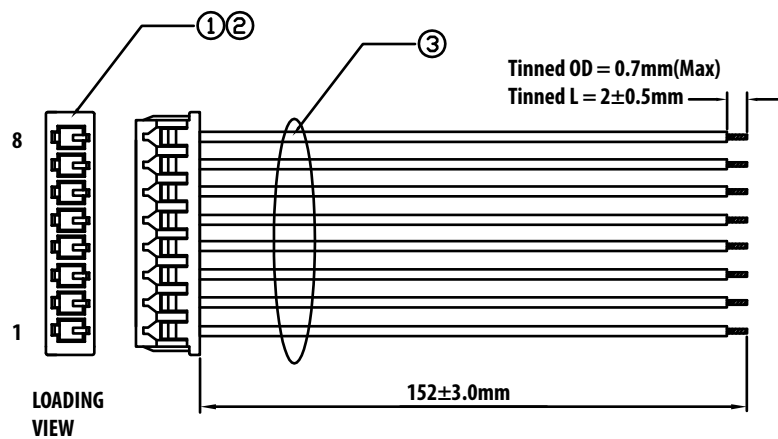

AEDS-Series (HEDS-8911-152)

Specification:

1. Housing, 8P, pitch: 1.25mm
2. Terminal, #26~28AWG
3. Wire, UL1007 #28AWG-STR
4. Blue color

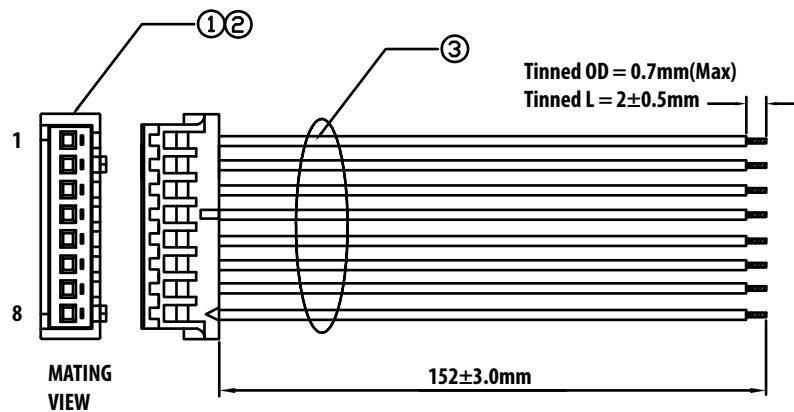

AEDT-Series (HEDT-8912-152)

Specification:

1. Housing, 8P, pitch: 1.25mm
2. Terminal, #26~30AWG
3. Wire, UL1007 #28AWG-STR
4. Grey color

Ordering Information

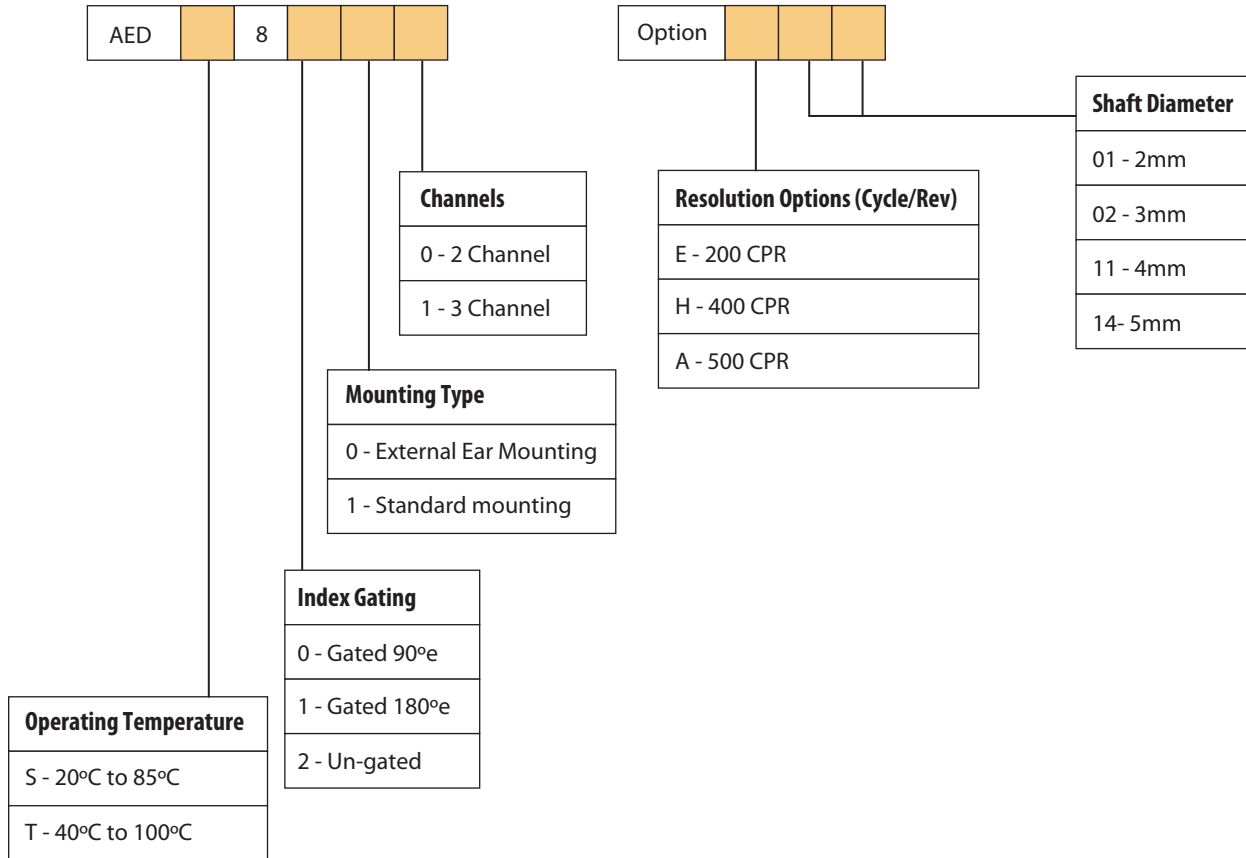

Connectors ordering information:

1. HEDS-8911-152 - Connectors for AEDS-8xxx series
2. HEDT-8912-152 - Connectors for AEDT-8xxx series

Alignment tool ordering information:

1. HEDS-8938-001 - Alignment tool for AEDx-8xxx-x01 series (2mm shaft diameter option)
2. HEDS-8938-002 - Alignment tool for AEDx-8xxx-x02 series (3mm shaft diameter option)
3. HEDS-8938-011 - Alignment tool for AEDx-8xxx-x11 series (4mm shaft diameter option)
4. HEDS-8938-014 - Alignment tool for AEDx-8xxx-x14 series (5mm shaft diameter option)

For product information and a complete list of distributors, please go to our web site: www.avagotech.com

Avago, Avago Technologies, and the A logo are trademarks of Avago Technologies in the United States and other countries. Data subject to change. Copyright © 2005-2014 Avago Technologies. All rights reserved. AV02-1240EN - July 7, 2014

AVAGO
TECHNOLOGIES