



Chipsmall Limited consists of a professional team with an average of over 10 year of expertise in the distribution of electronic components. Based in Hongkong, we have already established firm and mutual-benefit business relationships with customers from,Europe,America and south Asia,supplying obsolete and hard-to-find components to meet their specific needs.

With the principle of “Quality Parts,Customers Priority,Honest Operation,and Considerate Service”,our business mainly focus on the distribution of electronic components. Line cards we deal with include Microchip,ALPS,ROHM,Xilinx,Pulse,ON,Everlight and Freescale. Main products comprise IC,Modules,Potentiometer,IC Socket,Relay,Connector.Our parts cover such applications as commercial,industrial, and automotives areas.

We are looking forward to setting up business relationship with you and hope to provide you with the best service and solution. Let us make a better world for our industry!



Contact us

Tel: +86-755-8981 8866 Fax: +86-755-8427 6832

Email & Skype: info@chipsmall.com Web: www.chipsmall.com

Address: A1208, Overseas Decoration Building, #122 Zhenhua RD., Futian, Shenzhen, China



Important notice

Dear Customer,

On 7 February 2017 the former NXP Standard Product business became a new company with the tradename **Nexperia**. Nexperia is an industry leading supplier of Discrete, Logic and PowerMOS semiconductors with its focus on the automotive, industrial, computing, consumer and wearable application markets

In data sheets and application notes which still contain NXP or Philips Semiconductors references, use the references to Nexperia, as shown below.

Instead of <http://www.nxp.com>, <http://www.philips.com/> or <http://www.semiconductors.philips.com/>, use <http://www.nexperia.com>

Instead of sales.addresses@www.nxp.com or sales.addresses@www.semiconductors.philips.com, use salesaddresses@nexperia.com (email)

Replace the copyright notice at the bottom of each page or elsewhere in the document, depending on the version, as shown below:

- © NXP N.V. (year). All rights reserved or © Koninklijke Philips Electronics N.V. (year). All rights reserved

Should be replaced with:

- © **Nexperia B.V. (year). All rights reserved.**

If you have any questions related to the data sheet, please contact our nearest sales office via e-mail or telephone (details via salesaddresses@nexperia.com). Thank you for your cooperation and understanding,

Kind regards,

Team Nexperia

HEF4541B-Q100

Programmable timer

Rev. 2 — 31 December 2013

Product data sheet

1. General description

The HEF4541B-Q100 is a programmable timer. It consists of a 16-stage binary counter, an integrated oscillator to be used with external timing components, an automatic power-on reset and output control logic. The external components R_{TC} and C_{TC} determines the frequency of the oscillator within the frequency range 1 Hz to 100 kHz. An external clock signal at input RS can replace the oscillator. The timer advances on the positive-going transition of RS. A LOW on the auto reset input (AR) and a LOW on the master reset input (MR) enables the internal power-on reset. A HIGH level at input MR resets the counter independent on all other inputs. Resetting, disables the oscillator to provide no active power dissipation.

A HIGH at input AR turns off the power-on reset to provide a low quiescent power dissipation of the timer. The 16-stage counter divides the oscillator frequency by 2^8 , 2^{10} , 2^{13} or 2^{16} depending on the state of the address inputs (A0, A1). The divided oscillator frequency is available at output O. The phase input (PH) features a complementary output signal. When the mode select input (MODE) is LOW the timer is a single transition timer and when HIGH the timer is a 2^n frequency divider.

It operates over a recommended V_{DD} power supply range of 3 V to 15 V referenced to V_{SS} (usually ground). Unused inputs must be connected to V_{DD} , V_{SS} , or another input.

This product has been qualified to the Automotive Electronics Council (AEC) standard Q100 (Grade 1) and is suitable for use in automotive applications.

2. Features and benefits

- Automotive product qualification in accordance with AEC-Q100 (Grade 1)
 - ◆ Specified from $-40\text{ }^{\circ}\text{C}$ to $+85\text{ }^{\circ}\text{C}$ and from $-40\text{ }^{\circ}\text{C}$ to $+125\text{ }^{\circ}\text{C}$
- Fully static operation
- 5 V, 10 V, and 15 V parametric ratings
- Standardized symmetrical output characteristics
- ESD protection:
 - ◆ MIL-STD-883, method 3015 exceeds 2000 V
 - ◆ HBM JESD22-A114F exceeds 2000 V
 - ◆ MM JESD22-A115-A exceeds 200 V ($C = 200\text{ pF}$, $R = 0\text{ }\Omega$)
- Complies with JEDEC standard JESD 13-B



3. Ordering information

Table 1. Ordering information
 All types operate from $-40\text{ }^{\circ}\text{C}$ to $+125\text{ }^{\circ}\text{C}$.

Type number	Package		Version
	Name	Description	
HEF4541BT-Q100	SO14	plastic small outline package; 14 leads; body width 3.9 mm	SOT108-1

4. Functional diagram

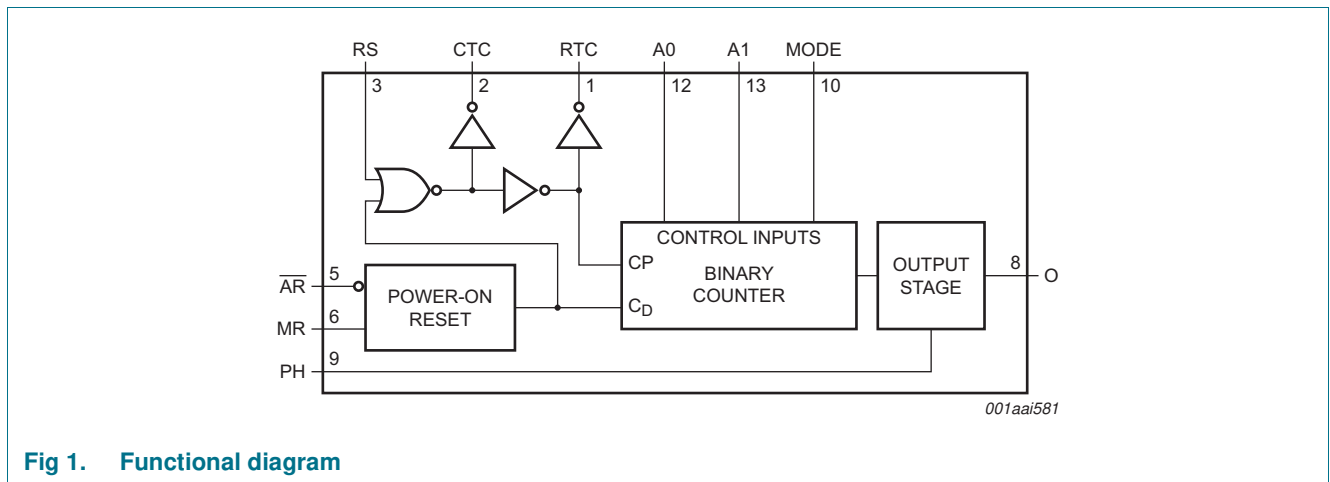

Fig 1. Functional diagram

5. Pinning information

5.1 Pinning

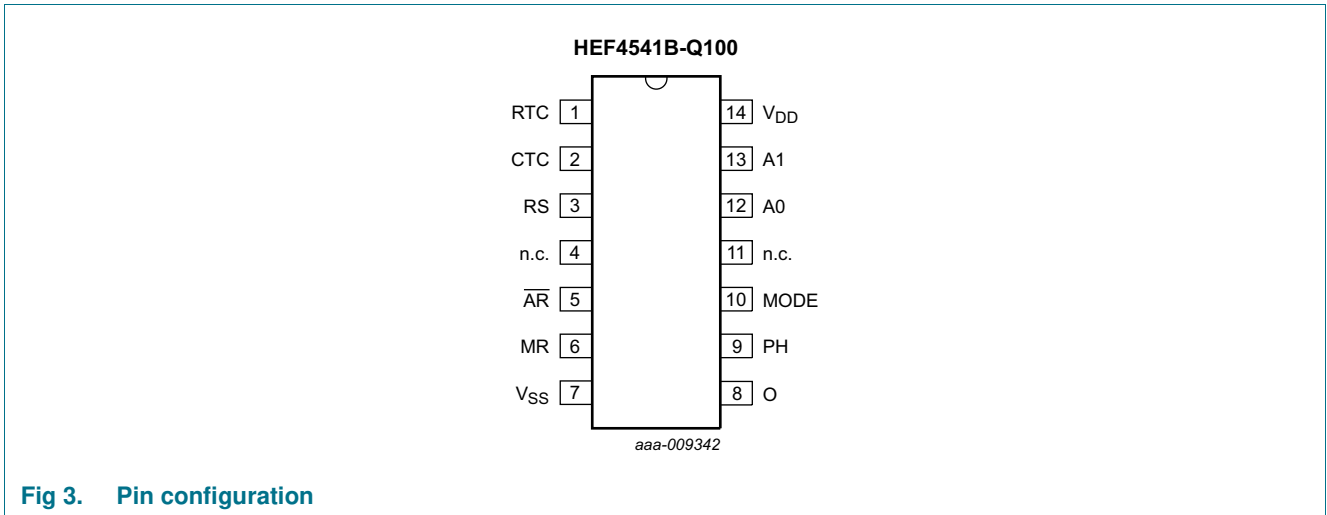

Fig 3. Pin configuration

5.2 Pin description

Table 2. Pin description

Symbol	Pin	Description
RTC	1	external resistor connection
CTC	2	external capacitor connection
RS	3	external resistor connection (RS) or external clock input
nc	4, 11	not connected
$\overline{\text{AR}}$	5	auto reset input (active low)
MR	6	master reset input
V _{SS}	7	ground (0 V)
O	8	timer output
PH	9	phase input
MODE	10	mode select input
A0, A1	12, 13	address inputs
V _{DD}	14	supply voltage

6. Functional description

Table 3. Function table^[1]

Input				MODE
AR	MR	PH	MODE	
H	L	X	X	auto reset disabled
L	L	X	X	auto reset enabled ^[2]
X	H	X	X	master reset active
X	L	X	H	normal operation selected division to output
X	L	X	L	single-cycle mode ^[3]
X	L	L	X	output initially LOW after reset
X	L	H	X	output initially HIGH, after reset

[1] H = HIGH voltage level; L = LOW voltage level; X = don't care.

[2] For correct power-on reset, the supply voltage should be above 8.5 V. For $V_{DD} < 8.5$ V, disable the auto reset and connect \overline{AR} to V_{DD} .

[3] The timer is initialized on a reset pulse and the output changes state after 2^{n-1} counts and remains in that state (latched). A master reset or a LOW to HIGH transition on the MODE input, resets this latch.

Table 4. Frequency selection table

A0	A1	Number of counter stages n	$\frac{f_{OSC}}{f_O} = 2^n$
L	L	13	8192
L	H	10	1024
H	L	8	256
H	H	16	65536

7. Limiting values

Table 5. Limiting values

In accordance with the Absolute Maximum Rating System (IEC 60134).

Symbol	Parameter	Conditions	Min	Max	Unit
V_{DD}	supply voltage		-0.5	+18	V
I_{IK}	input clamping current	$V_I < -0.5$ V or $V_I > V_{DD} + 0.5$ V	-	± 10	mA
V_I	input voltage		-0.5	$V_{DD} + 0.5$	V
I_{OK}	output clamping current	$V_O < -0.5$ V or $V_O > V_{DD} + 0.5$ V	-	± 10	mA
$I_{I/O}$	input/output current	O output	-	± 10	mA
T_{stg}	storage temperature		-65	+150	°C
T_{amb}	ambient temperature		-40	+125	°C
P_{tot}	total power dissipation	$T_{amb} = -40$ °C to +125 °C	^[1] -	500	mW
P	power dissipation		-	100	mW

[1] For SO14 package: P_{tot} derates linearly with 8 mW/K above 70 °C.

8. Recommended operating conditions

Table 6. Recommended operating conditions

Symbol	Parameter	Conditions	Min	Max	Unit
V_{DD}	supply voltage		3	15	V
V_I	input voltage		0	V_{DD}	V
T_{amb}	ambient temperature	in free air	-40	+125	°C
$\Delta t/\Delta V$	input transition rise and fall rate	$V_{DD} = 5\text{ V}$	-	3.75	$\mu\text{s/V}$
		$V_{DD} = 10\text{ V}$	-	0.5	$\mu\text{s/V}$
		$V_{DD} = 15\text{ V}$	-	0.08	$\mu\text{s/V}$

9. Static characteristics

Table 7. Static characteristics

$V_{SS} = 0\text{ V}$; $V_I = V_{SS}$ or V_{DD} ; unless otherwise specified.

Symbol	Parameter	Conditions	V_{DD}	$T_{amb} = -40\text{ °C}$		$T_{amb} = 25\text{ °C}$		$T_{amb} = 85\text{ °C}$		$T_{amb} = 125\text{ °C}$		Unit	
				Min	Max	Min	Max	Min	Max	Min	Max		
V_{IH}	HIGH-level input voltage	$ I_O < 1\ \mu\text{A}$	5 V	3.5	-	3.5	-	3.5	-	3.5	-	V	
			10 V	7.0	-	7.0	-	7.0	-	7.0	-	V	
			15 V	11.0	-	11.0	-	11.0	-	11.0	-	V	
V_{IL}	LOW-level input voltage	$ I_O < 1\ \mu\text{A}$	5 V	-	1.5	-	1.5	-	1.5	-	1.5	V	
			10 V	-	3.0	-	3.0	-	3.0	-	3.0	V	
			15 V	-	4.0	-	4.0	-	4.0	-	4.0	V	
V_{OH}	HIGH-level output voltage	$ I_O < 1\ \mu\text{A}$	5 V	4.95	-	4.95	-	4.95	-	4.95	-	V	
			10 V	9.95	-	9.95	-	9.95	-	9.95	-	V	
			15 V	14.95	-	14.95	-	14.95	-	14.95	-	V	
V_{OL}	LOW-level output voltage	$ I_O < 1\ \mu\text{A}$	5 V	-	0.05	-	0.05	-	0.05	-	0.05	V	
			10 V	-	0.05	-	0.05	-	0.05	-	0.05	V	
			15 V	-	0.05	-	0.05	-	0.05	-	0.05	V	
I_{OH}	HIGH-level output current	CTC, RTC;	$V_O = 2.5\text{ V}$	5 V	-	-1.4	-	-1.2	-	-0.95	-	-0.95	mA
			$V_O = 4.6\text{ V}$	5 V	-	-0.5	-	-0.4	-	-0.3	-	-0.3	mA
			$V_O = 9.5\text{ V}$	10 V	-	-1.4	-	-1.2	-	-0.95	-	-0.95	mA
			$V_O = 13.5\text{ V}$	15 V	-	-4.8	-	-4.0	-	-3.2	-	-3.2	mA
		O;	$V_O = 2.5\text{ V}$	5 V	-	-1.7	-	-1.4	-	-1.1	-	-1.1	mA
			$V_O = 4.6\text{ V}$	5 V	-	-0.64	-	-0.5	-	-0.36	-	-0.36	mA
			$V_O = 9.5\text{ V}$	10 V	-	-1.6	-	-1.3	-	-0.9	-	-0.9	mA
			$V_O = 13.5\text{ V}$	15 V	-	-4.2	-	-3.4	-	-2.4	-	-2.4	mA

Table 7. Static characteristics ...continued
 $V_{SS} = 0\text{ V}$; $V_I = V_{SS}$ or V_{DD} ; unless otherwise specified.

Symbol	Parameter	Conditions	V_{DD}	$T_{amb} = -40\text{ °C}$		$T_{amb} = 25\text{ °C}$		$T_{amb} = 85\text{ °C}$		$T_{amb} = 125\text{ °C}$		Unit
				Min	Max	Min	Max	Min	Max	Min	Max	
I_{OL}	LOW-level output current	CTC, RTC; $V_O = 0.4\text{ V}$	5 V	0.33	-	0.27	-	0.20	-	0.20	-	mA
			10 V	1.0	-	0.85	-	0.68	-	0.68	-	mA
			15 V	3.2	-	2.7	-	2.3	-	2.3	-	mA
		O; $V_O = 0.4\text{ V}$	5 V	0.64	-	0.5	-	0.36	-	0.36	-	mA
			10 V	1.6	-	1.3	-	0.9	-	0.9	-	mA
			15 V	4.2	-	3.2	-	2.4	-	2.4	-	mA
I_I	input leakage current		15 V	-	± 0.1	-	± 0.1	-	± 1.0	-	± 1.0	μA
I_{DD}	supply current	$I_O = 0\text{ A}$	5 V	-	5	-	5	-	150	-	150	μA
			10 V	-	10	-	10	-	300	-	300	μA
			15 V	-	20	-	20	-	600	-	600	μA
C_I	input capacitance		-	-	-	7.5	-	-	-	-	pF	

Table 8. Reset characteristics
 $V_{SS} = 0\text{ V}$; $V_I = V_{SS}$ or V_{DD} ; see [Table 12](#) for test conditions; unless otherwise specified.

Symbol	Parameter	Conditions	V_{DD}	$T_{amb} = -40\text{ °C}$		$T_{amb} = +25\text{ °C}$			$T_{amb} = +85\text{ °C}$		$T_{amb} = +125\text{ °C}$		Unit
				Min	Max	Min	Typ	Max	Min	Max	Min	Max	
I_{DD}	supply current	supply current for power-on reset enable; $\overline{AR} = \overline{MR} = 0\text{ V}$; Other inputs at 0 V or V_{DD}	5 V	-	80	-	20	80	-	230	-	230	μA
			10 V	-	750	-	250	600	-	700	-	700	μA
			15 V	-	1.6	-	0.5	1.3	-	1.5	-	1.5	mA
V_{DD}	supply voltage	supply voltage for automatic reset initialization; $\overline{AR} = \overline{MR} = 0\text{ V}$; Other inputs at 0 V or V_{DD}	-	-	-	8.5	5	-	-	-	-	-	V

10. Dynamic characteristics

Table 9. Dynamic characteristics

$V_{SS} = 0\text{ V}$; $T_{amb} = 25\text{ °C}$ unless otherwise specified. For test circuit, see [Figure 5](#).

Symbol	Parameter	Conditions	V_{DD}	Extrapolation formula	Min	Typ ^[1]	Max	Unit
t_{pd}	propagation delay	RS to O; 2 ⁸ selected; see Figure 4	5 V ^[2]	$348\text{ ns} + (0.55\text{ ns/pF})C_L$	-	375	750	ns
			10 V	$139\text{ ns} + (0.23\text{ ns/pF})C_L$	-	150	300	ns
			15 V	$102\text{ ns} + (0.16\text{ ns/pF})C_L$	-	110	220	ns
		RS to O; 2 ¹⁰ selected; see Figure 4	5 V	$398\text{ ns} + (0.55\text{ ns/pF})C_L$	-	425	850	ns
			10 V	$154\text{ ns} + (0.23\text{ ns/pF})C_L$	-	165	330	ns
			15 V	$112\text{ ns} + (0.16\text{ ns/pF})C_L$	-	120	240	ns
		RS to O; 2 ¹³ selected; see Figure 4	5 V	$483\text{ ns} + (0.55\text{ ns/pF})C_L$	-	510	1020	ns
			10 V	$179\text{ ns} + (0.23\text{ ns/pF})C_L$	-	190	380	ns
			15 V	$127\text{ ns} + (0.16\text{ ns/pF})C_L$	-	135	270	ns
		RS to O; 2 ¹⁶ selected; see Figure 4	5 V	$548\text{ ns} + (0.55\text{ ns/pF})C_L$	-	575	1150	ns
			10 V	$199\text{ ns} + (0.23\text{ ns/pF})C_L$	-	210	420	ns
			15 V	$142\text{ ns} + (0.16\text{ ns/pF})C_L$	-	150	300	ns
t_w	pulse width	RS LOW; MR HIGH; see Figure 4	5 V ^[3]		60	30	-	ns
			10 V		30	15	-	ns
			15 V		24	12	-	ns
$f_{clk(max)}$	maximum clock frequency	RS; see Figure 4	5 V		8	16	-	MHz
			10 V		15	30	-	MHz
			15 V		18	36	-	MHz
f_{osc}	oscillator frequency	$R_t = 5\text{ k}\Omega$; $C_t = 1\text{ nF}$; $R_S = 10\text{ k}\Omega$; see Figure 6	5 V		-	90	-	kHz
			10 V		-	90	-	kHz
			15 V		-	90	-	kHz
		$R_t = 56\text{ k}\Omega$; $C_t = 1\text{ nF}$; $R_S = 120\text{ k}\Omega$; see Figure 6	5 V		-	8	-	kHz
			10 V		-	8	-	kHz
			15 V		-	8	-	kHz

[1] The typical values of the propagation delay and transition times are calculated from the extrapolation formulas shown (C_L in pF).

[2] t_{pd} is the same as t_{PHL} and t_{PLH} .

[3] t_w is the same as $t_{WL(min)}$ and $t_{WH(min)}$.

Table 10. Dynamic power dissipation

P_D can be calculated from the formulas shown. $V_{SS} = 0\text{ V}$; $t_r = t_f \leq 20\text{ ns}$; $T_{amb} = 25\text{ }^\circ\text{C}$.

Symbol	Parameter	V_{DD}	Typical formula
P_D	dynamic power dissipation	Per package	
		5 V	$P_D = 1300 \times f_i + (f_o \times C_L \times V_{DD}^2)\ \mu\text{W}$
		10 V	$P_D = 5300 \times f_i + (f_o \times C_L \times V_{DD}^2)\ \mu\text{W}$
		15 V	$P_D = 12000 \times f_i + (f_o \times C_L \times V_{DD}^2)\ \mu\text{W}$
		Total, using the on-chip oscillator	
		5 V	$P_D = 1300 \times f_{osc} + f_o C_L V_{DD}^2 + 2C_{TC} V_{DD}^2 f_{osc} + 10V_{DD}\ \mu\text{W}$
		10 V	$P_D = 5300 \times f_{osc} + f_o C_L V_{DD}^2 + 2C_{TC} V_{DD}^2 f_{osc} + 100V_{DD}\ \mu\text{W}$
15 V	$P_D = 12000 \times f_{osc} + f_o C_L V_{DD}^2 + 2C_{TC} V_{DD}^2 f_{osc} + 400V_{DD}\ \mu\text{W}$		

[1] f_i = input frequency in MHz; f_o = output frequency in MHz; C_L = output load capacitance in pF; V_{DD} = supply voltage in V; f_{osc} = oscillator frequency in MHz; C_{TC} = timing capacitance in pF.

11. Waveforms

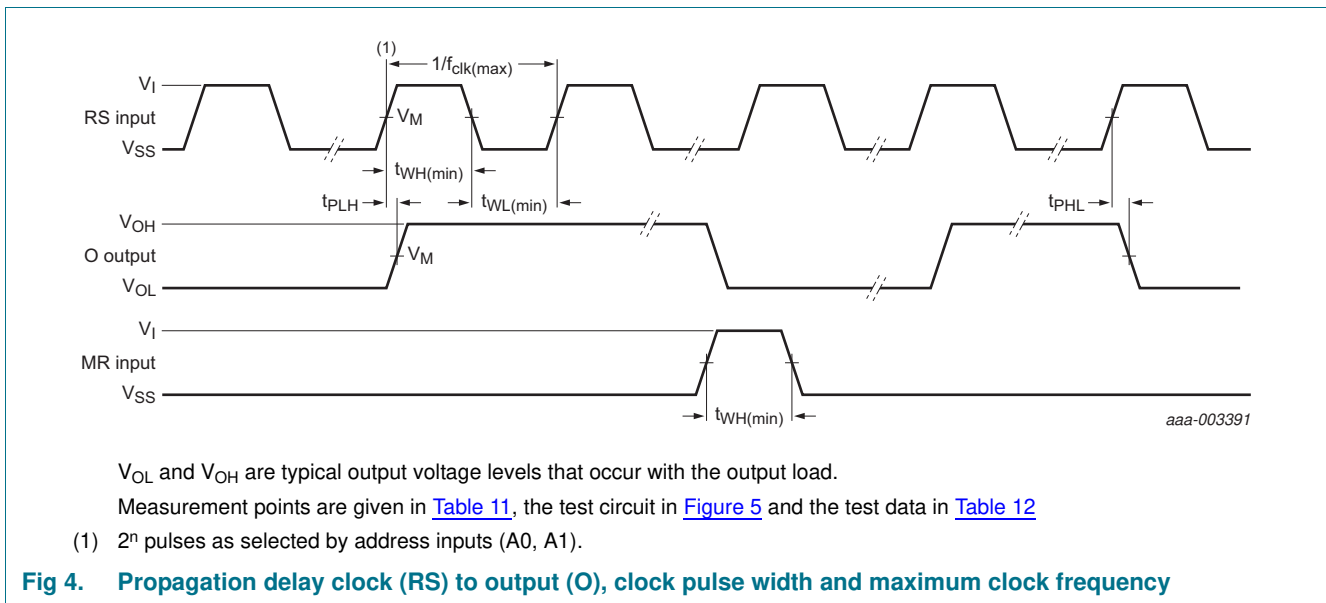
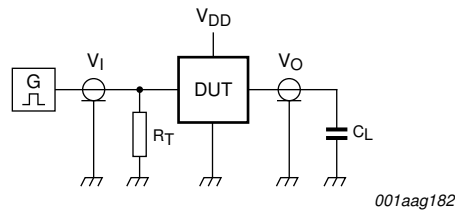

Table 11. Measurement points

Supply voltage	Input	Output
V_{DD}	V_M	V_M
5 V to 15 V	$0.5V_{DD}$	$0.5V_{DD}$



Test data is given in [Table 12](#).

Definitions for test circuit:

DUT - Device Under Test.

R_L = Load resistance.

C_L = load capacitance.

R_T = Termination resistance should be equal to output impedance of Z_o of the pulse generator.

Fig 5. Test circuit for measuring switching times

Table 12. Test data

Supply	Input	Load
V_{DD}	V_I	C_L
5 V to 15 V	V_{SS} or V_{DD}	50 pF
		t_r, t_f
		≤ 20 ns

12. Application information

RC oscillator timing component limitations

$R_{TC}C_{TC}$ determines the oscillator frequency, provided $R_{TC} \ll R_S$ and $R_S C_2 \ll R_{TC}C_{TC}$. The function of R_S is to minimize the influence of the forward voltage across the input protection diodes on the frequency. The stray capacitance C_2 should be kept as small as possible. In consideration of accuracy, C_{TC} must be larger than the inherent stray capacitance. R_{TC} must be larger than the LOCMOS 'ON' resistance in series with it, which typically is 500 Ω at $V_{DD} = 5\text{ V}$, 300 Ω at $V_{DD} = 10\text{ V}$ and 200 Ω at $V_{DD} = 15\text{ V}$.

The recommended values for these components to maintain agreement with the typical oscillation formula are: $C_{TC} \geq 100\text{ pF}$, up to any typical value, $10\text{ k}\Omega \leq R_{TC} \leq 1\text{ M}\Omega$.

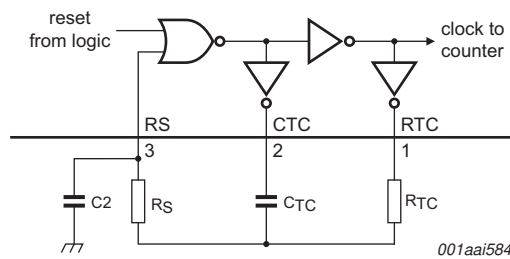

Typical formula for oscillator frequency: $f_{osc} = \frac{1}{2.3 \times R_{TC} \times C_{TC}}$.

Fig 6. External component connection for RC oscillator; $R_S \approx R_{TC}$

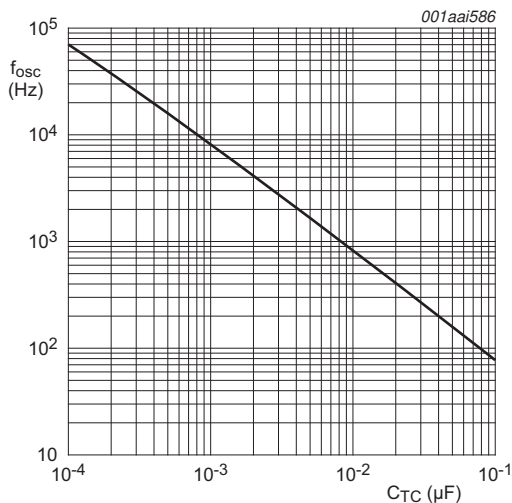

a. C_{TC} curve at $R_{TC} = 56\text{ k}\Omega$; $R_S = 120\text{ k}\Omega$.

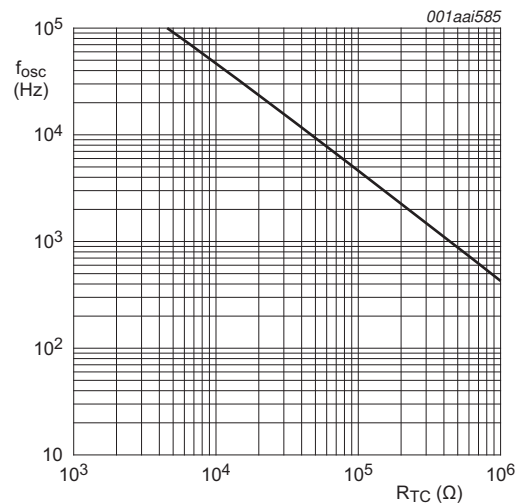

b. R_{TC} curve at $C_{TC} = 1\text{ nF}$; $R_S = 2 R_{TC}$.

Fig 7. RC oscillator frequency as a function of R_{TC} and C_{TC} at $V_{DD} = 5\text{ V to }15\text{ V}$; $T_{amb} = 25\text{ }^\circ\text{C}$

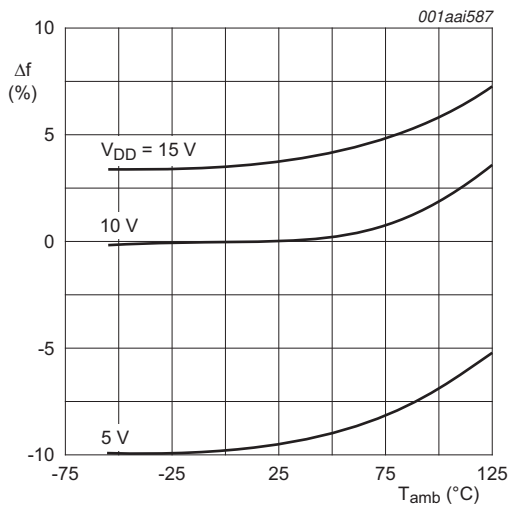

a. $R_{TC} = 56 \text{ k}\Omega$; $C_{TC} = 1 \text{ nF}$; $R_S = 0 \text{ }\Omega$.

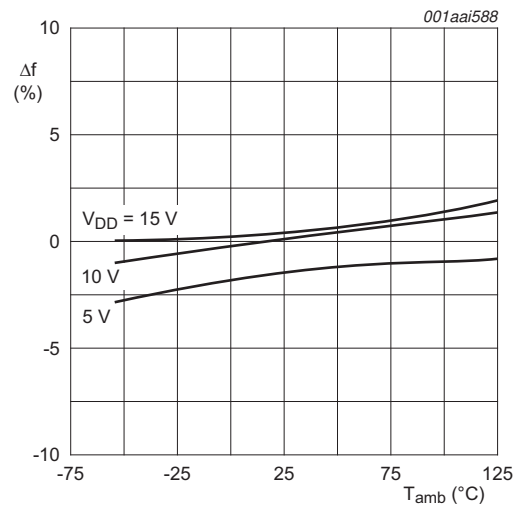

b. $R_{TC} = 56 \text{ k}\Omega$; $C_{TC} = 1 \text{ nF}$; $R_S = 120 \text{ k}\Omega$.

Fig 8. Frequency deviation (Δf) as a function of ambient temperature

13. Package outline

SO14: plastic small outline package; 14 leads; body width 3.9 mm

SOT108-1

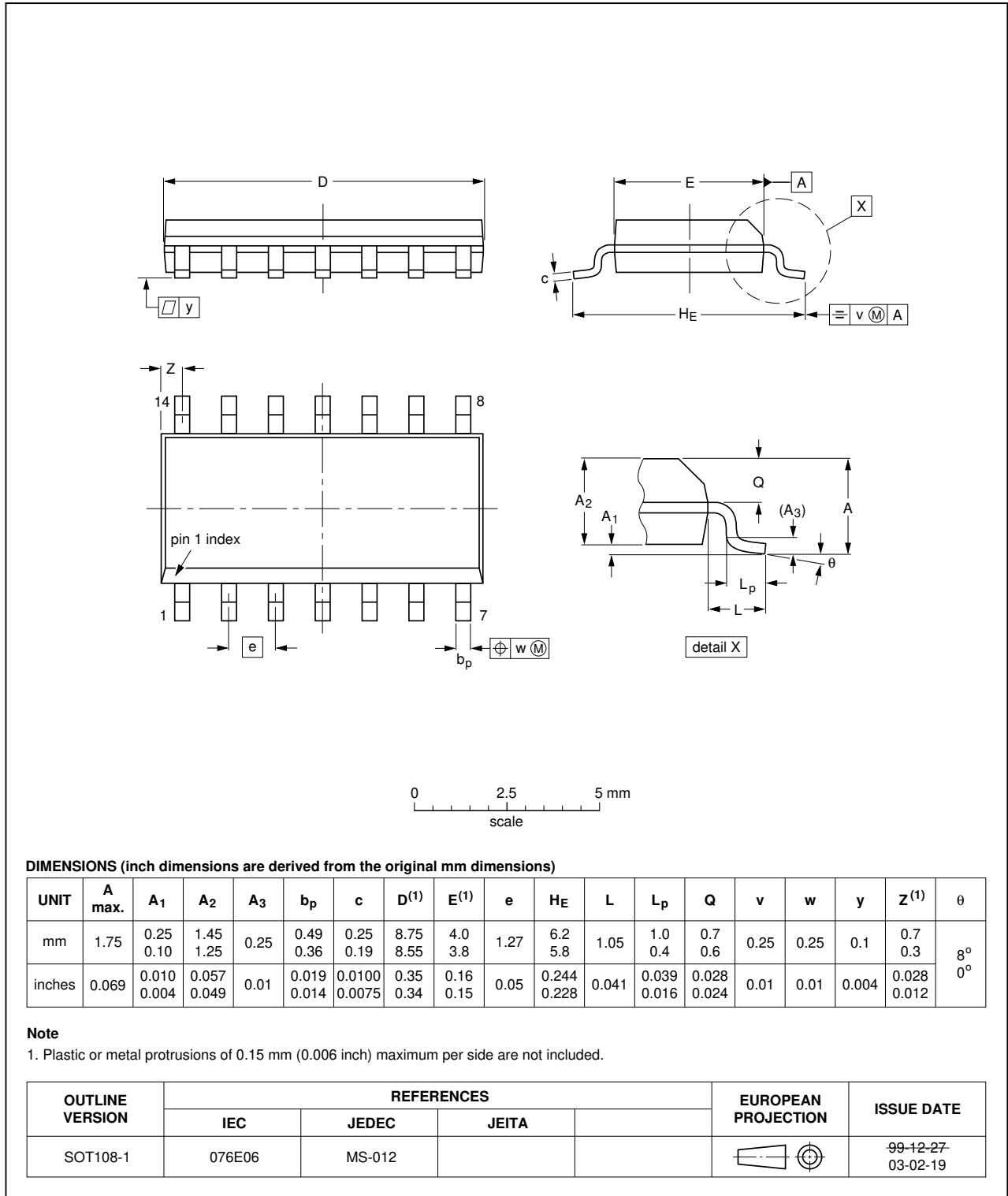

Fig 9. Package outline SOT108-1 (SO14)

14. Abbreviations

Table 13. Abbreviations

Acronym	Description
CMOS	Complementary Metal Oxide Semiconductor
DUT	Device Under Test
ESD	ElectroStatic Discharge
HBM	Human Body Model
MIL	Military
MM	Machine Model
TTL	Transistor-Transistor Logic

15. Revision history

Table 14. Revision history

Document ID	Release date	Data sheet status	Change notice	Supersedes
HEF4541B_Q100 v.2	20131231	Product data sheet	-	HEF4541B_Q100 v.1
Modifications:	• Maximum temperature changed to 125 °C throughout.			
HEF4541B_Q100 v.1	20131021	Product data sheet	-	-

16. Legal information

16.1 Data sheet status

Document status ^{[1][2]}	Product status ^[3]	Definition
Objective [short] data sheet	Development	This document contains data from the objective specification for product development.
Preliminary [short] data sheet	Qualification	This document contains data from the preliminary specification.
Product [short] data sheet	Production	This document contains the product specification.

[1] Please consult the most recently issued document before initiating or completing a design.

[2] The term 'short data sheet' is explained in section "Definitions".

[3] The product status of device(s) described in this document may have changed since this document was published and may differ in case of multiple devices. The latest product status information is available on the Internet at URL <http://www.nxp.com>.

16.2 Definitions

Draft — The document is a draft version only. The content is still under internal review and subject to formal approval, which may result in modifications or additions. NXP Semiconductors does not give any representations or warranties as to the accuracy or completeness of information included herein and shall have no liability for the consequences of use of such information.

Short data sheet — A short data sheet is an extract from a full data sheet with the same product type number(s) and title. A short data sheet is intended for quick reference only and should not be relied upon to contain detailed and full information. For detailed and full information see the relevant full data sheet, which is available on request via the local NXP Semiconductors sales office. In case of any inconsistency or conflict with the short data sheet, the full data sheet shall prevail.

Product specification — The information and data provided in a Product data sheet shall define the specification of the product as agreed between NXP Semiconductors and its customer, unless NXP Semiconductors and customer have explicitly agreed otherwise in writing. In no event however, shall an agreement be valid in which the NXP Semiconductors product is deemed to offer functions and qualities beyond those described in the Product data sheet.

16.3 Disclaimers

Limited warranty and liability — Information in this document is believed to be accurate and reliable. However, NXP Semiconductors does not give any representations or warranties, expressed or implied, as to the accuracy or completeness of such information and shall have no liability for the consequences of use of such information. NXP Semiconductors takes no responsibility for the content in this document if provided by an information source outside of NXP Semiconductors.

In no event shall NXP Semiconductors be liable for any indirect, incidental, punitive, special or consequential damages (including - without limitation - lost profits, lost savings, business interruption, costs related to the removal or replacement of any products or rework charges) whether or not such damages are based on tort (including negligence), warranty, breach of contract or any other legal theory.

Notwithstanding any damages that customer might incur for any reason whatsoever, NXP Semiconductors' aggregate and cumulative liability towards customer for the products described herein shall be limited in accordance with the *Terms and conditions of commercial sale* of NXP Semiconductors.

Right to make changes — NXP Semiconductors reserves the right to make changes to information published in this document, including without limitation specifications and product descriptions, at any time and without notice. This document supersedes and replaces all information supplied prior to the publication hereof.

Suitability for use in automotive applications — This NXP Semiconductors product has been qualified for use in automotive applications. Unless otherwise agreed in writing, the product is not designed, authorized or warranted to be suitable for use in life support, life-critical or safety-critical systems or equipment, nor in applications where failure or malfunction of an NXP Semiconductors product can reasonably be expected to result in personal injury, death or severe property or environmental damage. NXP Semiconductors and its suppliers accept no liability for inclusion and/or use of NXP Semiconductors products in such equipment or applications and therefore such inclusion and/or use is at the customer's own risk.

Applications — Applications that are described herein for any of these products are for illustrative purposes only. NXP Semiconductors makes no representation or warranty that such applications will be suitable for the specified use without further testing or modification.

Customers are responsible for the design and operation of their applications and products using NXP Semiconductors products, and NXP Semiconductors accepts no liability for any assistance with applications or customer product design. It is customer's sole responsibility to determine whether the NXP Semiconductors product is suitable and fit for the customer's applications and products planned, as well as for the planned application and use of customer's third party customer(s). Customers should provide appropriate design and operating safeguards to minimize the risks associated with their applications and products.

NXP Semiconductors does not accept any liability related to any default, damage, costs or problem which is based on any weakness or default in the customer's applications or products, or the application or use by customer's third party customer(s). Customer is responsible for doing all necessary testing for the customer's applications and products using NXP Semiconductors products in order to avoid a default of the applications and the products or of the application or use by customer's third party customer(s). NXP does not accept any liability in this respect.

Limiting values — Stress above one or more limiting values (as defined in the Absolute Maximum Ratings System of IEC 60134) will cause permanent damage to the device. Limiting values are stress ratings only and (proper) operation of the device at these or any other conditions above those given in the Recommended operating conditions section (if present) or the Characteristics sections of this document is not warranted. Constant or repeated exposure to limiting values will permanently and irreversibly affect the quality and reliability of the device.

Terms and conditions of commercial sale — NXP Semiconductors products are sold subject to the general terms and conditions of commercial sale, as published at <http://www.nxp.com/profile/terms>, unless otherwise agreed in a valid written individual agreement. In case an individual agreement is concluded only the terms and conditions of the respective agreement shall apply. NXP Semiconductors hereby expressly objects to applying the customer's general terms and conditions with regard to the purchase of NXP Semiconductors products by customer.

No offer to sell or license — Nothing in this document may be interpreted or construed as an offer to sell products that is open for acceptance or the grant, conveyance or implication of any license under any copyrights, patents or other industrial or intellectual property rights.

Export control — This document as well as the item(s) described herein may be subject to export control regulations. Export might require a prior authorization from competent authorities.

Translations — A non-English (translated) version of a document is for reference only. The English version shall prevail in case of any discrepancy between the translated and English versions.

16.4 Trademarks

Notice: All referenced brands, product names, service names and trademarks are the property of their respective owners.

17. Contact information

For more information, please visit: <http://www.nxp.com>

For sales office addresses, please send an email to: salesaddresses@nxp.com

18. Contents

1	General description	1
2	Features and benefits	1
3	Ordering information	2
4	Functional diagram	2
5	Pinning information	4
5.1	Pinning	4
5.2	Pin description	4
6	Functional description	5
7	Limiting values	5
8	Recommended operating conditions	6
9	Static characteristics	6
10	Dynamic characteristics	8
11	Waveforms	9
12	Application information	11
	RC oscillator timing component limitations	11
13	Package outline	13
14	Abbreviations	14
15	Revision history	14
16	Legal information	15
16.1	Data sheet status	15
16.2	Definitions	15
16.3	Disclaimers	15
16.4	Trademarks	16
17	Contact information	16
18	Contents	17

Please be aware that important notices concerning this document and the product(s) described herein, have been included in section 'Legal information'.

© NXP B.V. 2013.

All rights reserved.

For more information, please visit: <http://www.nxp.com>

For sales office addresses, please send an email to: salesaddresses@nxp.com

Date of release: 31 December 2013

Document identifier: HEF4541B_Q100