



Chipsmall Limited consists of a professional team with an average of over 10 year of expertise in the distribution of electronic components. Based in Hongkong, we have already established firm and mutual-benefit business relationships with customers from,Europe,America and south Asia,supplying obsolete and hard-to-find components to meet their specific needs.

With the principle of “Quality Parts,Customers Priority,Honest Operation,and Considerate Service”,our business mainly focus on the distribution of electronic components. Line cards we deal with include Microchip,ALPS,ROHM,Xilinx,Pulse,ON,Everlight and Freescale. Main products comprise IC,Modules,Potentiometer,IC Socket,Relay,Connector.Our parts cover such applications as commercial,industrial, and automotives areas.

We are looking forward to setting up business relationship with you and hope to provide you with the best service and solution. Let us make a better world for our industry!



Contact us

Tel: +86-755-8981 8866 Fax: +86-755-8427 6832

Email & Skype: info@chipsmall.com Web: www.chipsmall.com

Address: A1208, Overseas Decoration Building, #122 Zhenhua RD., Futian, Shenzhen, China



HEF4938B

Dual precision monostable multivibrator

Rev. 6 — 15 November 2011

Product data sheet

1. General description

The HEF4938B is a dual retriggerable-resettable monostable multivibrator. Each multivibrator has an active LOW trigger/retrigger input ($n\bar{A}$), an active HIGH trigger/retrigger input (nB), an overriding active LOW direct reset input ($n\bar{CD}$), an output (nQ) and its complement ($n\bar{Q}$), and two pins (CEXT, always connected to ground, and nREXT/CEXT) for connecting the external timing components C_{EXT} and R_{EXT} . The typical pulse width variation over the specified temperature range is $\pm 0.2\%$.

The multivibrator may be triggered by either the positive or the negative edges of the input pulse and will produce an accurate output pulse with a pulse width range of 10 μs to infinity. The duration and accuracy of the output pulse are determined by the external timing components C_{EXT} and R_{EXT} . The output pulse width (t_W) is equal to $R_{EXT} \times C_{EXT}$. The linear design techniques in LOC MOS (Local Oxide CMOS) guarantee precise control of the output pulse width. A LOW level at $n\bar{CD}$ terminates the output pulse immediately. The trigger inputs' Schmitt trigger action makes the circuit highly tolerant of slower rise and fall times.

It operates over a recommended V_{DD} power supply range of 3 V to 15 V referenced to V_{SS} (usually ground). Unused inputs must be connected to V_{DD} , V_{SS} , or another input.

2. Features and benefits

- Separate reset inputs
- Triggering from leading or trailing edge
- Tolerant of slow trigger rise and fall times
- Fully static operation
- 5 V, 10 V, and 15 V parametric ratings
- Standardized symmetrical output characteristics
- Specified from $-40\text{ }^\circ\text{C}$ to $+85\text{ }^\circ\text{C}$
- Complies with JEDEC standard JESD 13-B

3. Ordering information

Table 1. Ordering information

All types operate from $-40\text{ }^\circ\text{C}$ to $+85\text{ }^\circ\text{C}$.

Type number	Package		Version
	Name	Description	
HEF4938BP	DIP16	plastic dual in-line package; 16 leads (300 mil)	SOT38-4
HEF4938BT	SO16	plastic small outline package; 16 leads; body width 3.9 mm	SOT109-1



4. Functional diagram

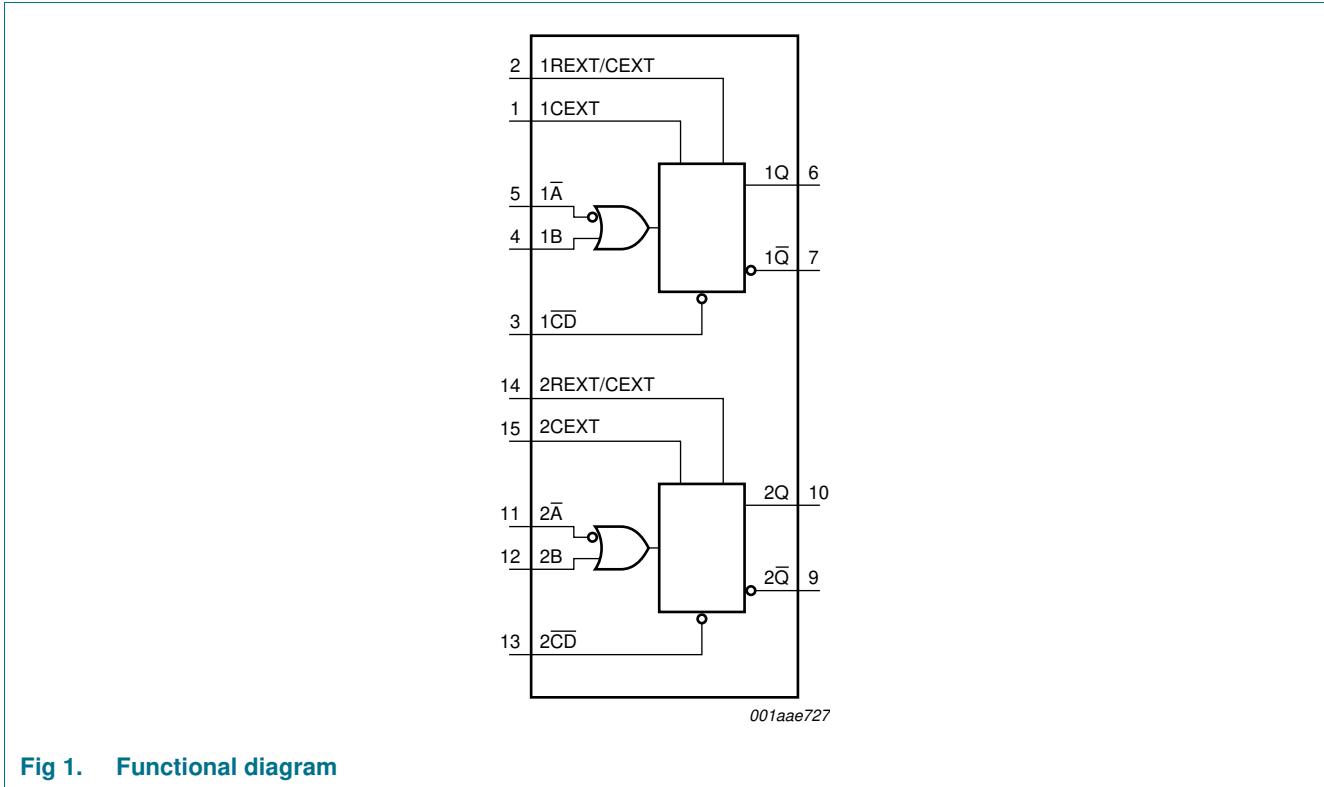

Fig 1. Functional diagram

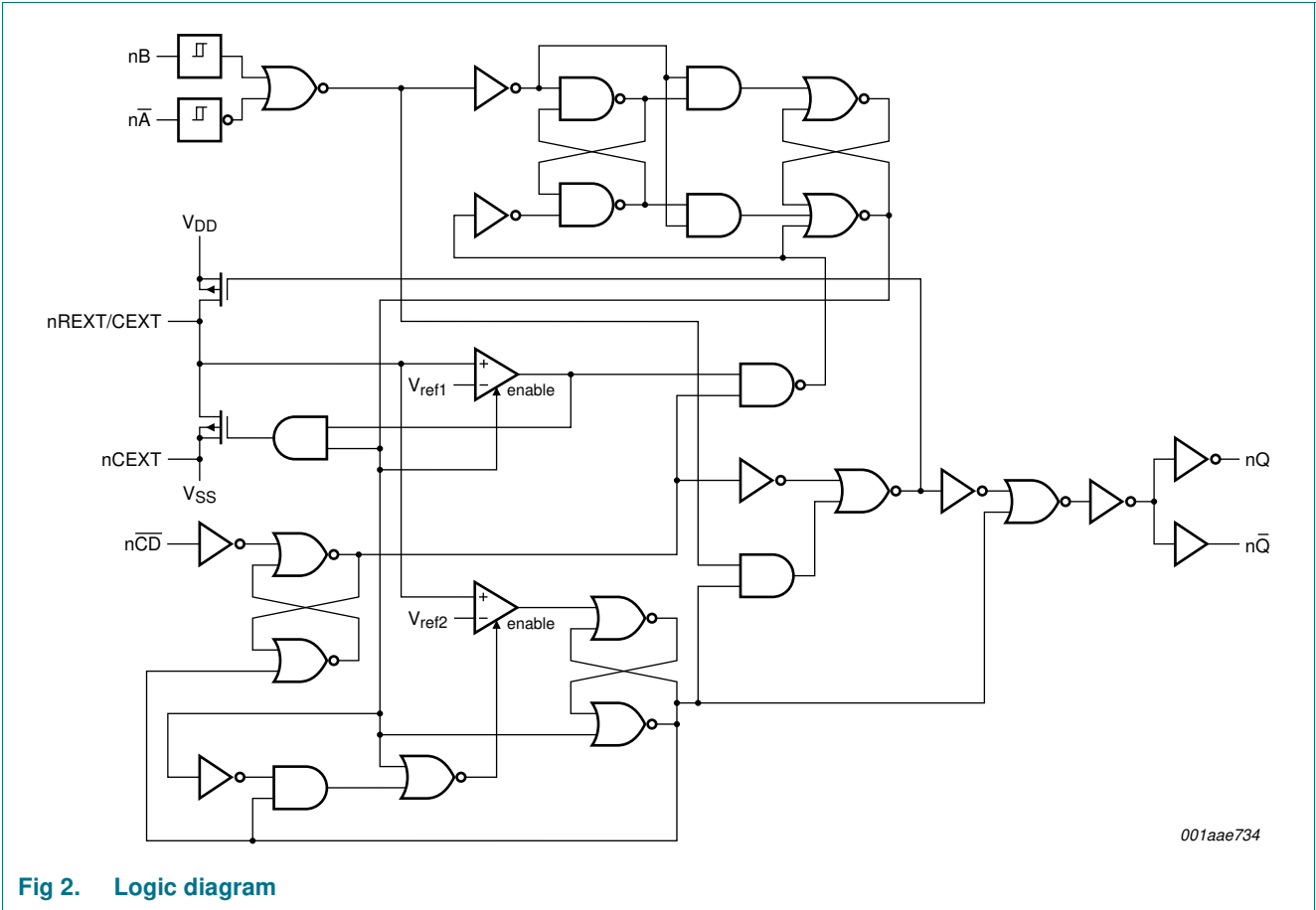

Fig 2. Logic diagram

5. Pinning information

5.1 Pinning

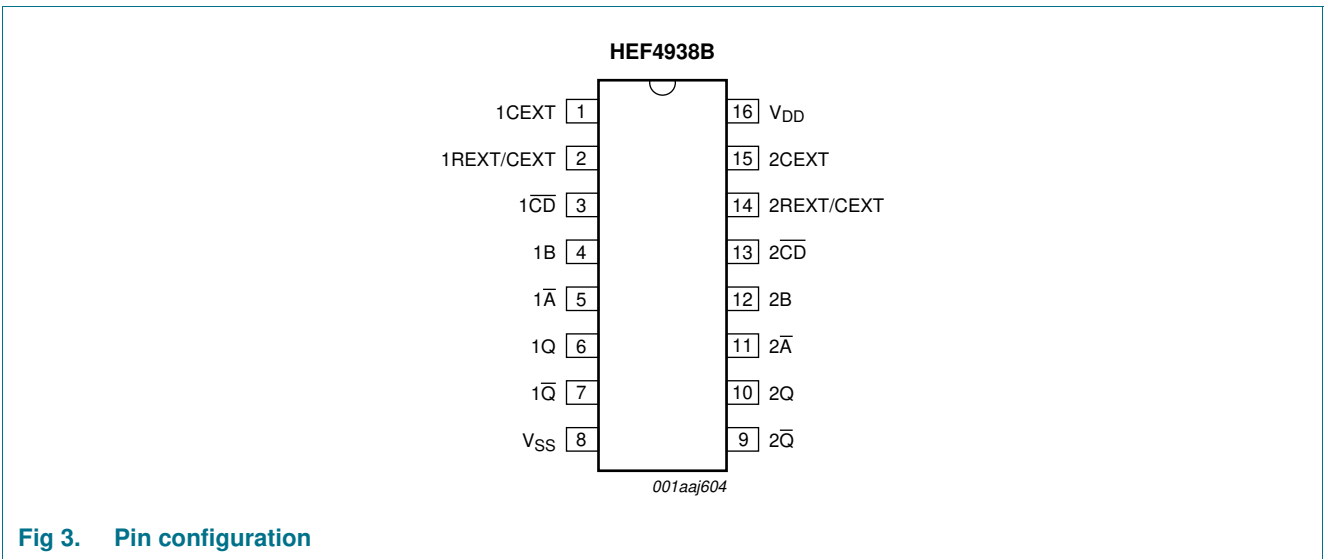

Fig 3. Pin configuration

5.2 Pin description

Table 2. Pin description

Symbol	Pin	Description
1C _{EXT} , 2C _{EXT}	1, 15	external capacitor connection (always connected to ground)
1R _{EXT} /C _{EXT} , 2R _{EXT} /C _{EXT}	2, 14	external capacitor/resistor connection
1 \overline{CD} , 2 \overline{CD}	3, 13	direct reset input (active LOW)
1B, 2B	4, 12	input (LOW-to-HIGH triggered)
1 \overline{A} , 2 \overline{A}	5, 11	input (HIGH-to-LOW triggered)
1Q, 2Q	6, 10	output
1 \overline{Q} , 2 \overline{Q}	7, 9	complementary output (active LOW)
V _{SS}	8	ground supply voltage
V _{DD}	16	supply voltage

6. Functional description

Table 3. Function table

Inputs			Outputs	
n \overline{A}	nB	n \overline{CD}	nQ	n \overline{Q}
↓	L	H		
H	↑	H		
X	X	L	L	H

[1] H = HIGH voltage level; L = LOW voltage level; X = don't care; ↑ = positive-going transition; ↓ = negative-going transition;

= one HIGH level output pulse, with the pulse width determined by C_{EXT} and R_{EXT};

= one LOW level output pulse, with the pulse width determined by C_{EXT} and R_{EXT}.

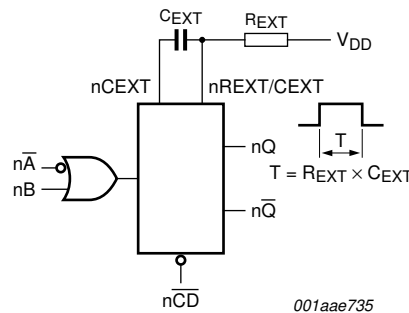

The external timing resistor R_{EXT} minimum value is 5 kΩ. Its maximum permissible resistance, which holds the specified accuracy of t_w (nQ, n \overline{Q} output), depends on the leakage current of the capacitor C_{EXT} and the leakage of the HEF4938B. The external timing capacitor C_{EXT} minimum value is 2000 pF with no upper limit.

Fig 4. Connection of the external timing components R_{EXT} and C_{EXT}

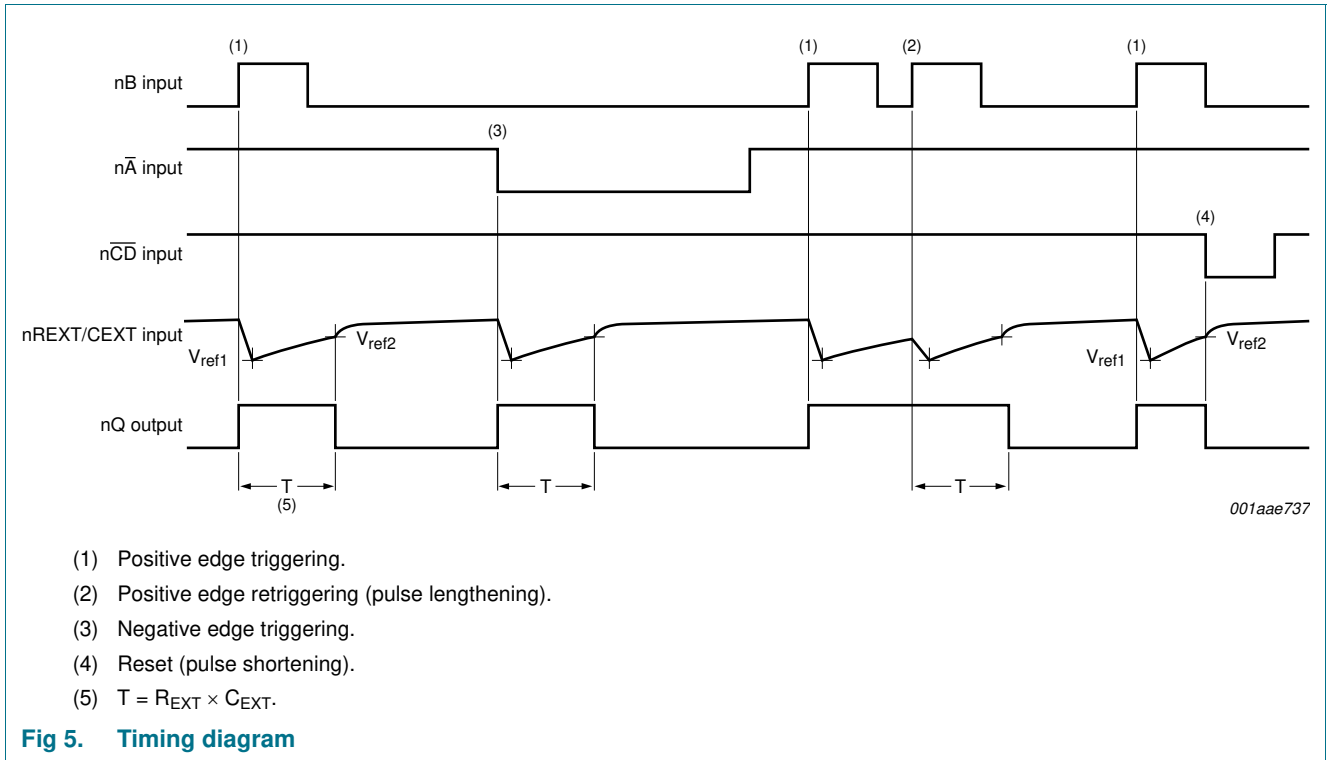

7. Limiting values

Table 4. Limiting values

In accordance with the Absolute Maximum Rating System (IEC 60134). Voltages are referenced to $V_{SS} = 0\text{ V}$ (ground)

Symbol	Parameter	Conditions	Min	Max	Unit	
V_{DD}	supply voltage		-0.5	+18	V	
I_{IK}	input clamping current	$V_I < -0.5\text{ V}$ or $V_I > V_{DD} + 0.5\text{ V}$	-	± 10	mA	
V_I	input voltage		-0.5	$V_{DD} + 0.5$	V	
I_{OK}	output clamping current	$V_I < -0.5\text{ V}$ or $V_I > V_{DD} + 0.5\text{ V}$		± 10	mA	
$I_{I/O}$	input/output current		-	± 10	mA	
I_{DD}	supply current			50	mA	
T_{stg}	storage temperature		-65	+150	°C	
T_{amb}	ambient temperature		-40	+125	°C	
P_{tot}	total power dissipation	$T_{amb} = -40\text{ °C to }+85\text{ °C}$				
		DIP16 package	[1]	-	750	mW
		SO16 package	[2]	-	500	mW
P	power dissipation	per output	-	100	mW	

[1] For DIP16 package: P_{tot} derates linearly with 12 mW/K above 70 °C.

[2] For SO16 package: P_{tot} derates linearly with 8 mW/K above 70 °C.

8. Recommended operating conditions

Table 5. Recommended operating conditions

Symbol	Parameter	Conditions	Min	Typ	Max	Unit
V_{DD}	supply voltage		3	-	15	V
V_I	input voltage		0	-	V_{DD}	V
T_{amb}	ambient temperature	in free air	-40	-	+125	°C
$\Delta t/\Delta V$	input transition rise and fall rate	$V_{DD} = 5\text{ V}$	-	-	3.75	$\mu\text{s/V}$
		$V_{DD} = 10\text{ V}$	-	-	0.5	$\mu\text{s/V}$
		$V_{DD} = 15\text{ V}$	-	-	0.08	$\mu\text{s/V}$

9. Static characteristics

Table 6. Static characteristics

$V_{SS} = 0\text{ V}$; $V_I = V_{SS}$ or V_{DD} unless otherwise specified.

Symbol	Parameter	Conditions	V_{DD}	$T_{amb} = -40\text{ °C}$		$T_{amb} = 25\text{ °C}$		$T_{amb} = 85\text{ °C}$		Unit
				Min	Max	Min	Max	Min	Max	
V_{IH}	HIGH-level input voltage	$ I_O < 1\ \mu\text{A}$	5 V	3.5	-	3.5	-	3.5	-	V
			10 V	7.0	-	7.0	-	7.0	-	V
			15 V	11.0	-	11.0	-	11.0	-	V
V_{IL}	LOW-level input voltage	$ I_O < 1\ \mu\text{A}$	5 V	-	1.5	-	1.5	-	1.5	V
			10 V	-	3.0	-	3.0	-	3.0	V
			15 V	-	4.0	-	4.0	-	4.0	V
V_{OH}	HIGH-level output voltage	$ I_O < 1\ \mu\text{A}$	5 V	4.95	-	4.95	-	4.95	-	V
			10 V	9.95	-	9.95	-	9.95	-	V
			15 V	14.95	-	14.95	-	14.95	-	V
V_{OL}	LOW-level output voltage	$ I_O < 1\ \mu\text{A}$	5 V	-	0.05	-	0.05	-	0.05	V
			10 V	-	0.05	-	0.05	-	0.05	V
			15 V	-	0.05	-	0.05	-	0.05	V
I_{OH}	HIGH-level output current	$V_O = 2.5\text{ V}$	5 V	-	-1.7	-	-1.4	-	-1.1	mA
		$V_O = 4.6\text{ V}$	5 V	-	-0.64	-	-0.5	-	-0.36	mA
		$V_O = 9.5\text{ V}$	10 V	-	-1.6	-	-1.3	-	-0.9	mA
		$V_O = 13.5\text{ V}$	15 V	-	-4.2	-	-3.4	-	-2.4	mA
I_{OL}	LOW-level output current	$V_O = 0.4\text{ V}$	5 V	0.64	-	0.5	-	0.36	-	mA
		$V_O = 0.5\text{ V}$	10 V	1.6	-	1.3	-	0.9	-	mA
		$V_O = 1.5\text{ V}$	15 V	4.2	-	3.4	-	2.4	-	mA
I_I	input leakage current	pins 2 and 14	15 V	-	± 0.1	-	± 0.1	-	± 1.0	μA
I_{DD}	supply current	active state	5 V	-	-	(Typical = 55)		-	-	μA
			10 V	-	-	(Typical = 150)		-	-	μA
			15 V	-	-	(Typical = 220)		-	-	μA

Table 6. Static characteristics ...continued
 $V_{SS} = 0\text{ V}$; $V_I = V_{SS}$ or V_{DD} unless otherwise specified.

Symbol	Parameter	Conditions	V_{DD}	$T_{amb} = -40\text{ }^{\circ}\text{C}$		$T_{amb} = 25\text{ }^{\circ}\text{C}$		$T_{amb} = 85\text{ }^{\circ}\text{C}$		Unit
				Min	Max	Min	Max	Min	Max	
I_{DD}	supply current	$I_O = 0\text{ A}$	5 V	-	5	-	5	-	150	μA
			10 V	-	10	-	10	-	300	μA
			15 V	-	20	-	20	-	600	μA
C_I	input capacitance		-	-	-	7.5	-	-	pF	

[1] Only one monostable is switching: current present during output pulse (output Q is HIGH).

10. Dynamic characteristics

Table 7. Dynamic characteristics
 $V_{SS} = 0\text{ V}$; $T_{amb} = 25\text{ }^{\circ}\text{C}$; for test circuit see [Figure 11](#); unless otherwise specified.

Symbol	Parameter	Conditions	V_{DD}	Extrapolation formula ^[1]	Min	Typ	Max	Unit
t_{PHL}	HIGH to LOW propagation delay	$n\bar{A}$, $n\bar{B}$ to $n\bar{Q}$; see Figure 6	5 V	$193\text{ ns} + (0.55\text{ ns/pF})C_L$	-	220	440	ns
			10 V	$74\text{ ns} + (0.23\text{ ns/pF})C_L$	-	85	190	ns
			15 V	$52\text{ ns} + (0.16\text{ ns/pF})C_L$	-	60	120	ns
		$n\bar{C}\bar{D}$ to $n\bar{Q}$; see Figure 6	5 V	$98\text{ ns} + (0.55\text{ ns/pF})C_L$	-	125	250	ns
			10 V	$44\text{ ns} + (0.23\text{ ns/pF})C_L$	-	55	110	ns
			15 V	$32\text{ ns} + (0.16\text{ ns/pF})C_L$	-	40	80	ns
t_{PLH}	LOW to HIGH propagation delay	$n\bar{A}$, $n\bar{B}$ to $n\bar{Q}$; see Figure 6	5 V	$173\text{ ns} + (0.55\text{ ns/pF})C_L$	-	200	460	ns
			10 V	$79\text{ ns} + (0.23\text{ ns/pF})C_L$	-	90	180	ns
			15 V	$52\text{ ns} + (0.16\text{ ns/pF})C_L$	-	60	120	ns
		$n\bar{C}\bar{D}$ to $n\bar{Q}$; see Figure 6	5 V	$98\text{ ns} + (0.55\text{ ns/pF})C_L$	-	125	250	ns
			10 V	$44\text{ ns} + (0.23\text{ ns/pF})C_L$	-	55	110	ns
			15 V	$32\text{ ns} + (0.16\text{ ns/pF})C_L$	-	40	80	ns
t_{rec}	recovery time	$n\bar{C}\bar{D}$ to $n\bar{A}$, $n\bar{B}$; see Figure 7	5 V		-	20	40	ns
			10 V		-	10	20	ns
			15 V		-	5	10	ns
t_{trig}	retrigger time	$n\bar{Q}$, $n\bar{Q}$ to $n\bar{A}$, $n\bar{B}$; see Figure 7	5 V		0	-	-	ns
			10 V		0	-	-	ns
			15 V		0	-	-	ns
t_w	pulse width	\bar{A} input LOW; minimum width; see Figure 7	5 V		90	45	-	ns
			10 V		30	15	-	ns
			15 V		24	12	-	ns
		$n\bar{B}$ input HIGH; minimum width; see Figure 7	5 V		50	25	-	ns
			10 V		24	12	-	ns
			15 V		20	10	-	ns
		$n\bar{Q}$ or $n\bar{Q}$ output; $R_{EXT} = 100\text{ k}\Omega$; $C_{EXT} = 0.1\text{ }\mu\text{F}$; see Figure 7	5 V		9.3	10.0	10.6	ms
			10 V		9.2	9.9	10.5	ms
			15 V		9.1	9.8	10.4	ms

Table 7. Dynamic characteristics ...continued
 $V_{SS} = 0\text{ V}$; $T_{amb} = 25\text{ }^{\circ}\text{C}$; for test circuit see [Figure 11](#); unless otherwise specified.

Symbol	Parameter	Conditions	V_{DD}	Extrapolation formula ^[1]	Min	Typ	Max	Unit
Δt_w	pulse width variation	nQ or \overline{nQ} output variation over temperature (T_{amb}) range; see Figure 8	5 V		-	± 0.2	-	%
			10 V		-	± 0.2	-	%
			15 V		-	± 0.2	-	%
		nQ or \overline{nQ} output variation over V_{DD} voltage range 5 V to 15 V; see Figure 9			-	± 1.5	-	%
		nQ or \overline{nQ} output variation between same package devices; $R_{EXT} = 100\text{ k}\Omega$; $C_{EXT} = 2\text{ nF}$ to $10\text{ }\mu\text{F}$	5 V		-	± 1	-	%
		10 V		-	± 1	-	%	
		15 V		-	± 1	-	%	
C_i	input capacitance	nR_{EXT}/C_{EXT}			-	15	-	pF

[1] The typical values of the propagation delay and transition times are calculated from the extrapolation formulas shown (C_L in pF).

11. Waveforms

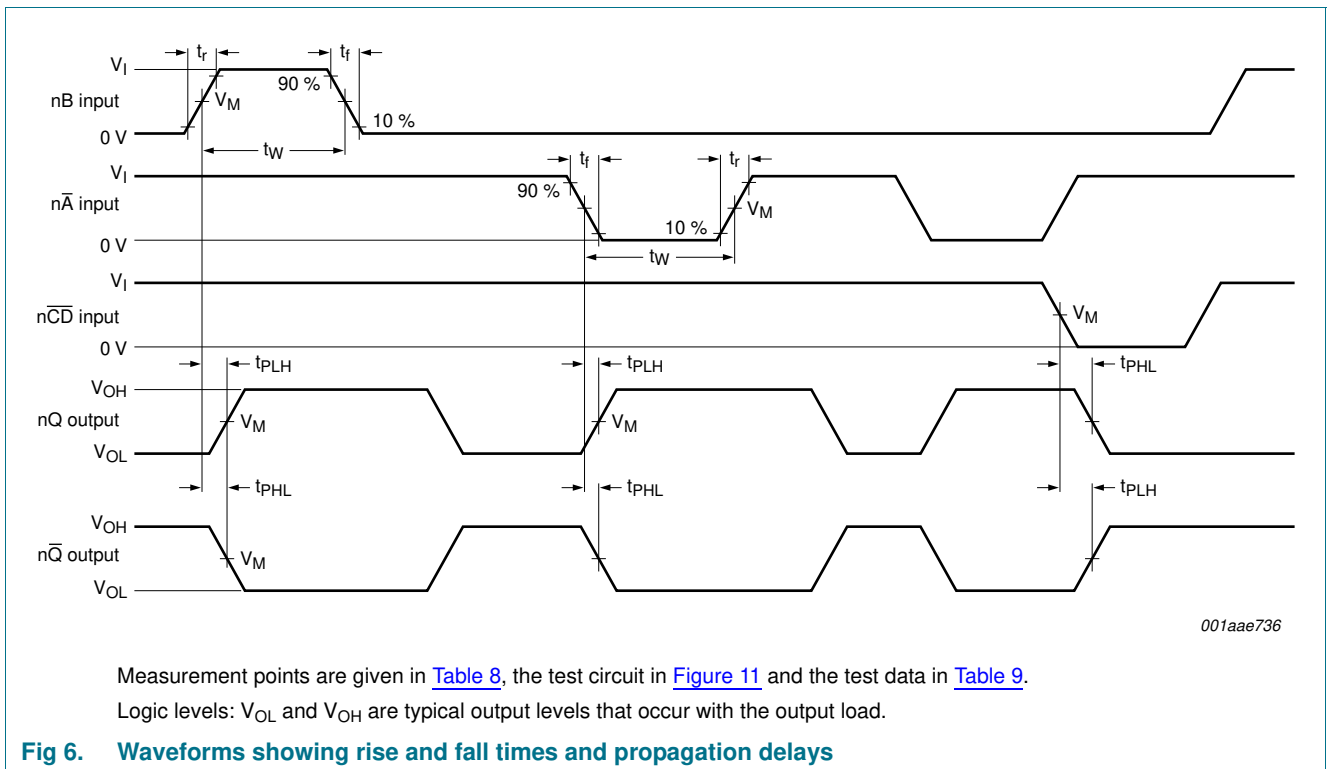
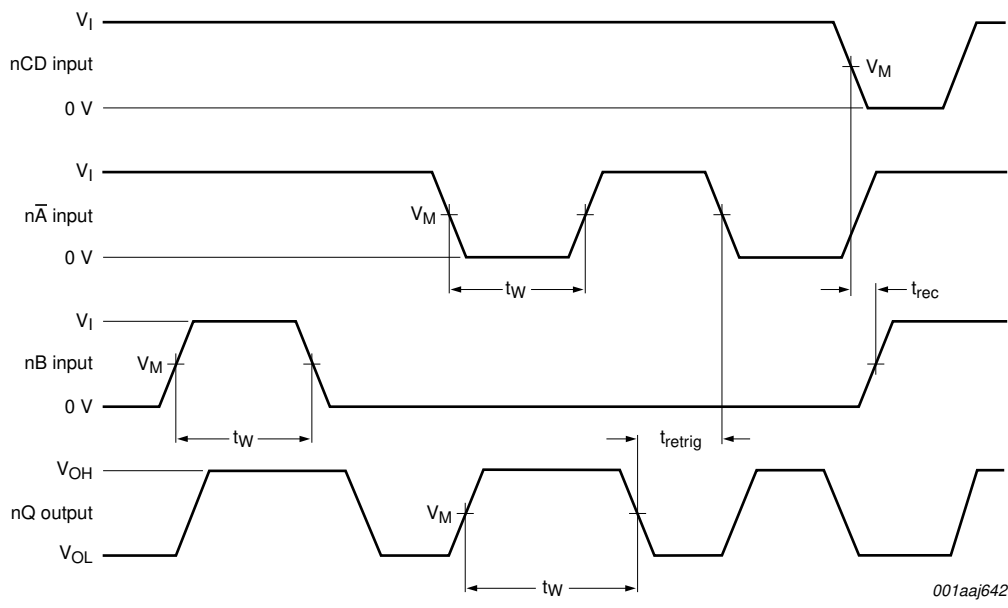

Table 8. Measurement points

Supply voltage	Input	Output
V_{DD}	V_M	V_M
5 V to 15 V	$0.5V_{DD}$	$0.5V_{DD}$



001aaj642

Measurement points are given in [Table 8](#), the test circuit in [Figure 11](#) and the test data in [Table 9](#).
 Logic levels: V_{OL} and V_{OH} are typical output levels that occur with the output load.

Fig 7. Waveforms showing minimum nA, nB, and nQ pulse widths and recovery and retrigger times

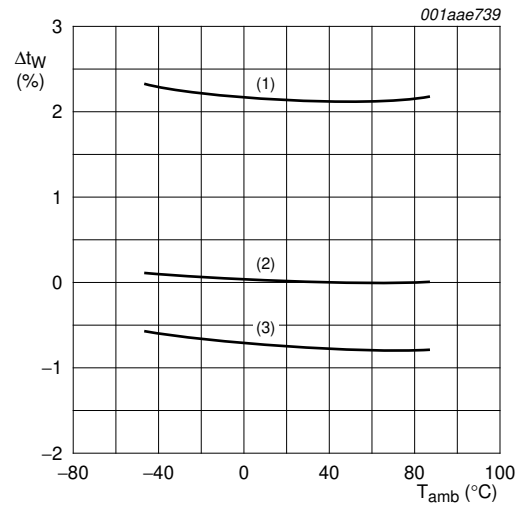
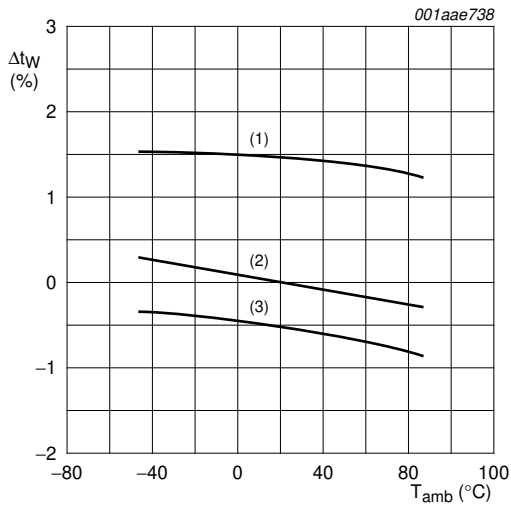

- a. $R_{EXT} = 100\text{ k}\Omega$; $C_{EXT} = 100\text{ nF}$
 0 % at $V_{DD} = 10\text{ V}$ and $T_{amb} = 25\text{ }^\circ\text{C}$
- (1) $V_{DD} = 5\text{ V}$.
 - (2) $V_{DD} = 10\text{ V}$.
 - (3) $V_{DD} = 15\text{ V}$.

- b. $R_{EXT} = 100\text{ k}\Omega$; $C_{EXT} = 2\text{ nF}$

Fig 8. Typical normalized change in output pulse width as a function of ambient temperature

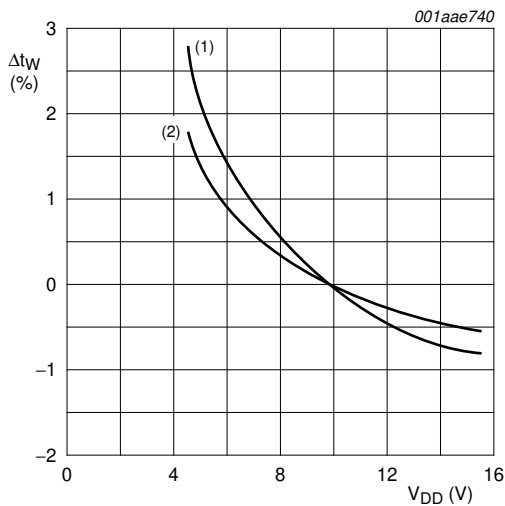

- $T_{amb} = 25\text{ }^\circ\text{C}$; 0 % at $V_{DD} = 10\text{ V}$; $R_{EXT} = 100\text{ k}\Omega$
- (1) $C_{EXT} = 2\text{ nF}$.
 - (2) $C_{EXT} = 100\text{ nF}$.

Fig 9. Typical normalized change in output pulse width as a function of the supply voltage

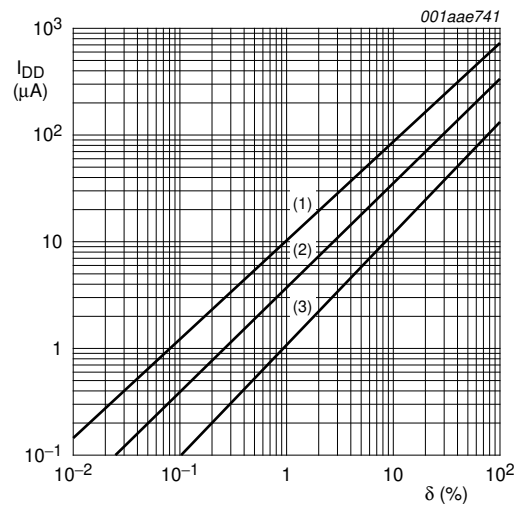

- $R_{EXT} = 100\text{ k}\Omega$; $C_{EXT} = 100\text{ nF}$; $C_L = 50\text{ pF}$;
 one monostable multivibrator switching only
- (1) $V_{DD} = 15\text{ V}$.
 - (2) $V_{DD} = 10\text{ V}$.
 - (3) $V_{DD} = 5\text{ V}$.

Fig 10. Total supply current as a function of the output duty factor

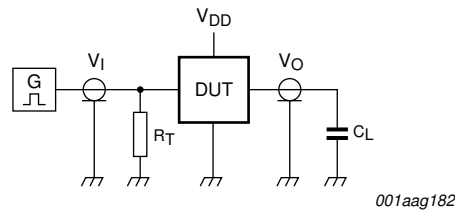

Test data is given in [Table 9](#).

Definitions for test circuit:

DUT = Device Under Test.

C_L = load capacitance including jig and probe capacitance.

R_T = termination resistance should be equal to the output impedance Z_o of the pulse generator.

Fig 11. Test circuit

Table 9. Test data

Supply voltage	Input		Load
V_{DD}	V_I	t_r, t_f	C_L
5 V to 15 V	V_{SS} or V_{DD}	≤ 20 ns	50 pF

12. Package outline

DIP16: plastic dual in-line package; 16 leads (300 mil)

SOT38-4

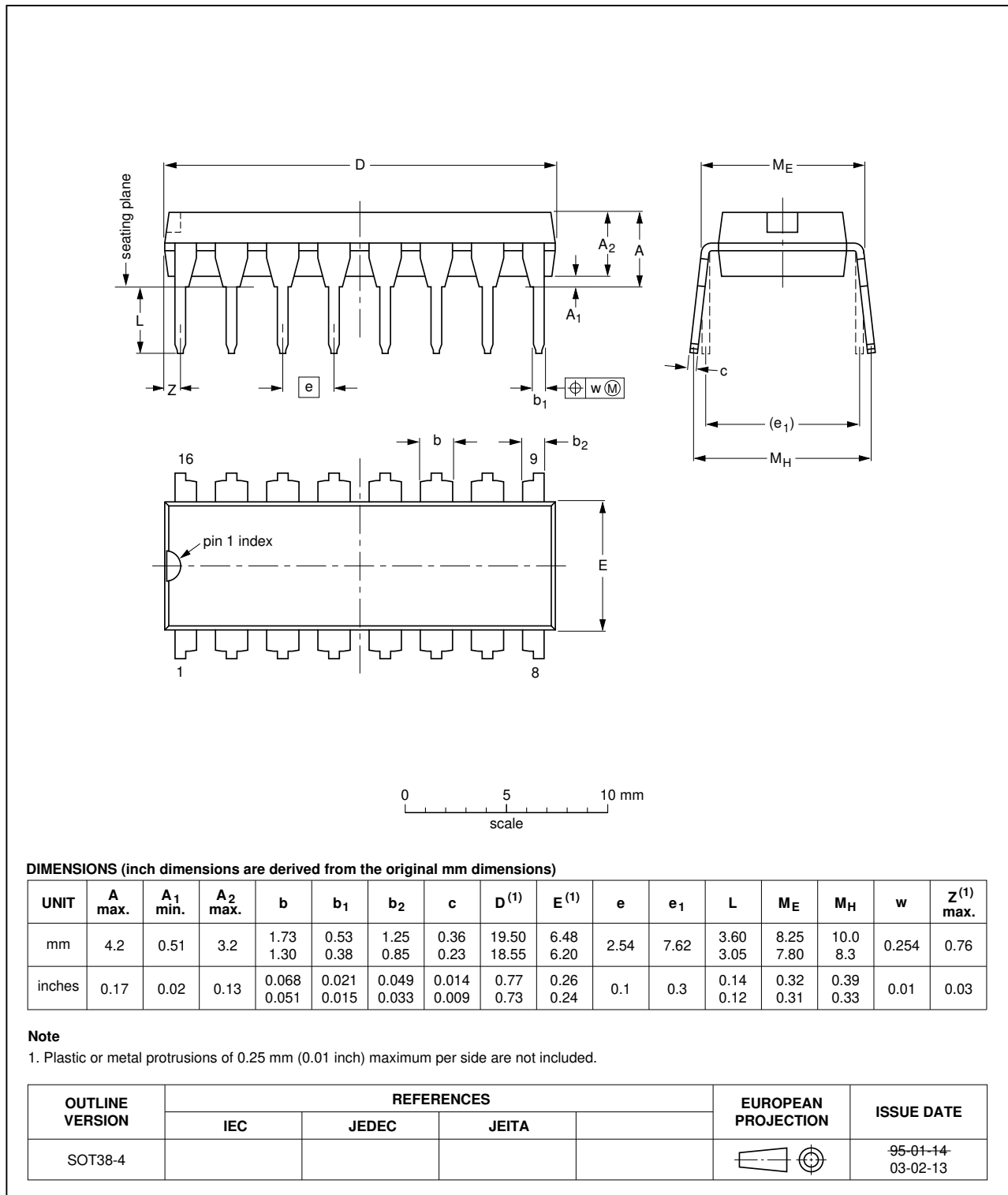

Fig 12. Package outline SOT38-4 (DIP16)

SO16: plastic small outline package; 16 leads; body width 3.9 mm

SOT109-1

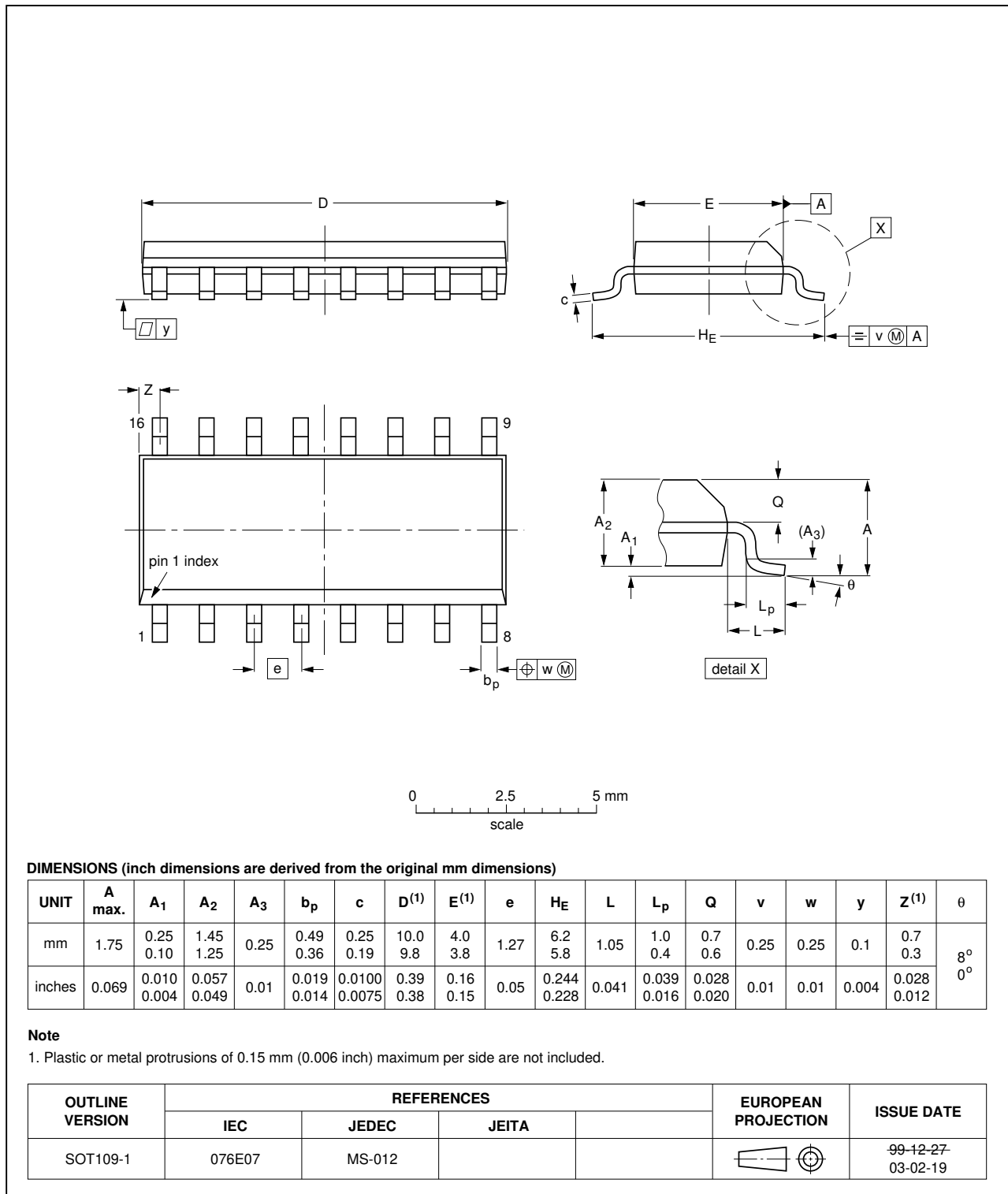

Fig 13. Package outline SOT109-1 (SO16)

13. Revision history

Table 10. Revision history

Document ID	Release date	Data sheet status	Change notice	Supersedes
HEF4938B v.6	20111115	Product data sheet	-	HEF4938B v.5
Modifications:	<ul style="list-style-type: none">• Section Applications removed• Table 6: I_{OH} minimum values changed to maximum• Figure 11: added "DUT = Device Under Test"			
HEF4938B v.5	20100106	Product data sheet	-	HEF4938B v.4
HEF4938B v.4	20090309	Product data sheet	-	HEF4938B_CNV v.3
HEF4938B_CNV v.3	19950101	Product specification	-	HEF4938B_CNV v.2
HEF4938B_CNV v.2	19950101	Product specification	-	-

14. Legal information

14.1 Data sheet status

Document status ^{[1][2]}	Product status ^[3]	Definition
Objective [short] data sheet	Development	This document contains data from the objective specification for product development.
Preliminary [short] data sheet	Qualification	This document contains data from the preliminary specification.
Product [short] data sheet	Production	This document contains the product specification.

[1] Please consult the most recently issued document before initiating or completing a design.

[2] The term 'short data sheet' is explained in section "Definitions".

[3] The product status of device(s) described in this document may have changed since this document was published and may differ in case of multiple devices. The latest product status information is available on the Internet at URL <http://www.nxp.com>.

14.2 Definitions

Draft — The document is a draft version only. The content is still under internal review and subject to formal approval, which may result in modifications or additions. NXP Semiconductors does not give any representations or warranties as to the accuracy or completeness of information included herein and shall have no liability for the consequences of use of such information.

Short data sheet — A short data sheet is an extract from a full data sheet with the same product type number(s) and title. A short data sheet is intended for quick reference only and should not be relied upon to contain detailed and full information. For detailed and full information see the relevant full data sheet, which is available on request via the local NXP Semiconductors sales office. In case of any inconsistency or conflict with the short data sheet, the full data sheet shall prevail.

Product specification — The information and data provided in a Product data sheet shall define the specification of the product as agreed between NXP Semiconductors and its customer, unless NXP Semiconductors and customer have explicitly agreed otherwise in writing. In no event however, shall an agreement be valid in which the NXP Semiconductors product is deemed to offer functions and qualities beyond those described in the Product data sheet.

14.3 Disclaimers

Limited warranty and liability — Information in this document is believed to be accurate and reliable. However, NXP Semiconductors does not give any representations or warranties, expressed or implied, as to the accuracy or completeness of such information and shall have no liability for the consequences of use of such information.

In no event shall NXP Semiconductors be liable for any indirect, incidental, punitive, special or consequential damages (including - without limitation - lost profits, lost savings, business interruption, costs related to the removal or replacement of any products or rework charges) whether or not such damages are based on tort (including negligence), warranty, breach of contract or any other legal theory.

Notwithstanding any damages that customer might incur for any reason whatsoever, NXP Semiconductors' aggregate and cumulative liability towards customer for the products described herein shall be limited in accordance with the *Terms and conditions of commercial sale* of NXP Semiconductors.

Right to make changes — NXP Semiconductors reserves the right to make changes to information published in this document, including without limitation specifications and product descriptions, at any time and without notice. This document supersedes and replaces all information supplied prior to the publication hereof.

Suitability for use — NXP Semiconductors products are not designed, authorized or warranted to be suitable for use in life support, life-critical or safety-critical systems or equipment, nor in applications where failure or

malfunction of an NXP Semiconductors product can reasonably be expected to result in personal injury, death or severe property or environmental damage. NXP Semiconductors accepts no liability for inclusion and/or use of NXP Semiconductors products in such equipment or applications and therefore such inclusion and/or use is at the customer's own risk.

Applications — Applications that are described herein for any of these products are for illustrative purposes only. NXP Semiconductors makes no representation or warranty that such applications will be suitable for the specified use without further testing or modification.

Customers are responsible for the design and operation of their applications and products using NXP Semiconductors products, and NXP Semiconductors accepts no liability for any assistance with applications or customer product design. It is customer's sole responsibility to determine whether the NXP Semiconductors product is suitable and fit for the customer's applications and products planned, as well as for the planned application and use of customer's third party customer(s). Customers should provide appropriate design and operating safeguards to minimize the risks associated with their applications and products.

NXP Semiconductors does not accept any liability related to any default, damage, costs or problem which is based on any weakness or default in the customer's applications or products, or the application or use by customer's third party customer(s). Customer is responsible for doing all necessary testing for the customer's applications and products using NXP Semiconductors products in order to avoid a default of the applications and the products or of the application or use by customer's third party customer(s). NXP does not accept any liability in this respect.

Limiting values — Stress above one or more limiting values (as defined in the Absolute Maximum Ratings System of IEC 60134) will cause permanent damage to the device. Limiting values are stress ratings only and (proper) operation of the device at these or any other conditions above those given in the Recommended operating conditions section (if present) or the Characteristics sections of this document is not warranted. Constant or repeated exposure to limiting values will permanently and irreversibly affect the quality and reliability of the device.

Terms and conditions of commercial sale — NXP Semiconductors products are sold subject to the general terms and conditions of commercial sale, as published at <http://www.nxp.com/profile/terms>, unless otherwise agreed in a valid written individual agreement. In case an individual agreement is concluded only the terms and conditions of the respective agreement shall apply. NXP Semiconductors hereby expressly objects to applying the customer's general terms and conditions with regard to the purchase of NXP Semiconductors products by customer.

No offer to sell or license — Nothing in this document may be interpreted or construed as an offer to sell products that is open for acceptance or the grant, conveyance or implication of any license under any copyrights, patents or other industrial or intellectual property rights.

Export control — This document as well as the item(s) described herein may be subject to export control regulations. Export might require a prior authorization from competent authorities.

Non-automotive qualified products — Unless this data sheet expressly states that this specific NXP Semiconductors product is automotive qualified, the product is not suitable for automotive use. It is neither qualified nor tested in accordance with automotive testing or application requirements. NXP Semiconductors accepts no liability for inclusion and/or use of non-automotive qualified products in automotive equipment or applications.

In the event that customer uses the product for design-in and use in automotive applications to automotive specifications and standards, customer (a) shall use the product without NXP Semiconductors' warranty of the product for such automotive applications, use and specifications, and (b) whenever customer uses the product for automotive applications beyond

NXP Semiconductors' specifications such use shall be solely at customer's own risk, and (c) customer fully indemnifies NXP Semiconductors for any liability, damages or failed product claims resulting from customer design and use of the product for automotive applications beyond NXP Semiconductors' standard warranty and NXP Semiconductors' product specifications.

14.4 Trademarks

Notice: All referenced brands, product names, service names and trademarks are the property of their respective owners.

15. Contact information

For more information, please visit: <http://www.nxp.com>

For sales office addresses, please send an email to: salesaddresses@nxp.com

16. Contents

1	General description	1
2	Features and benefits	1
3	Ordering information	1
4	Functional diagram	2
5	Pinning information	3
5.1	Pinning	3
5.2	Pin description	4
6	Functional description	4
7	Limiting values	5
8	Recommended operating conditions	6
9	Static characteristics	6
10	Dynamic characteristics	7
11	Waveforms	8
12	Package outline	12
13	Revision history	14
14	Legal information	15
14.1	Data sheet status	15
14.2	Definitions	15
14.3	Disclaimers	15
14.4	Trademarks	16
15	Contact information	16
16	Contents	17

Please be aware that important notices concerning this document and the product(s) described herein, have been included in section 'Legal information'.

© NXP B.V. 2011.

All rights reserved.

For more information, please visit: <http://www.nxp.com>

For sales office addresses, please send an email to: salesaddresses@nxp.com

Date of release: 15 November 2011

Document identifier: HEF4938B