



Chipsmall Limited consists of a professional team with an average of over 10 year of expertise in the distribution of electronic components. Based in Hongkong, we have already established firm and mutual-benefit business relationships with customers from,Europe,America and south Asia,supplying obsolete and hard-to-find components to meet their specific needs.

With the principle of "Quality Parts,Customers Priority,Honest Operation,and Considerate Service",our business mainly focus on the distribution of electronic components. Line cards we deal with include Microchip,ALPS,ROHM,Xilinx,Pulse,ON,Everlight and Freescale. Main products comprise IC,Modules,Potentiometer,IC Socket,Relay,Connector.Our parts cover such applications as commercial,industrial, and automotives areas.

We are looking forward to setting up business relationship with you and hope to provide you with the best service and solution. Let us make a better world for our industry!



Contact us

Tel: +86-755-8981 8866 Fax: +86-755-8427 6832

Email & Skype: info@chipsmall.com Web: www.chipsmall.com

Address: A1208, Overseas Decoration Building, #122 Zhenhua RD., Futian, Shenzhen, China



Inexpensive DC to 32 MBd Fiberoptic Solutions for Industrial, Medical, Telecom, and Proprietary Data Communication Applications



Application Note 1121

Introduction

Low-cost fiberoptic data-communication links have been used to replace copper wire in numerous industrial, medical, and proprietary applications. The fiberoptic transmitter and receiver circuits in this publication address a wide range of applications. These recommended circuits are compatible with unencoded or burst-mode communication protocols originally developed for use with copper wire. Complete TTL compatible digital transceiver solutions, including the schematic, printed circuit artwork, and material lists, are presented in this application note, so that users of this low-cost fiberoptic technology do not need to do any analog design. Designers are encouraged to embed these complete fiberoptic solutions into their products and various methods for electronically downloading the reference designs are described.

Why Use Optical Fibers?

Copper wire is an established technology that has been successfully used to transmit data in a wide range of industrial, medical and proprietary applications, but copper can be difficult or impossible to be used in numerous situations. By using differential line receivers, optocouplers, or transformers conventional copper wire cables can be used to transmit data in applications where the reference or ground potentials of two systems are different, but during and after the initial installation great care must still be taken not to corrupt the data with noise induced into the cable's metallic shields by adjacent power lines or differences in ground potential. Unlike copper wires, optical fibers do not require rigorous grounding rules to avoid ground loop interference, and fiberoptic cables do not need termination resistors to avoid reflections. Optical transceivers and cables can be designed into systems so that they survive lightning strikes that would normally damage metallic conductors or wire input/output (I/O) cards; in essence, fiberoptic data links are used in electrically noisy environments where copper wire fails. In addition to all of these inherent advantages there are two other reasons why optical fibers are beginning to replace copper wires. The first reason is that training and simple tools are now available.

The second reason is that when using plastic optical fiber (POF), or hard clad silica (HCS) fiber, the total cost of the data communication link is roughly the same as when using copper wires.

Wire Communication Protocols and Optical Data Links

Many existing serial wire communication protocols were developed for differential line receivers or optocouplers that can sense the DC component of the data communication signal. This type of serial data is often called arbitrary duty factor data because it can remain in the logic "1" or logic "0" state for indefinite periods of time. Arbitrary duty factor data has an average value, which can instantaneously be anywhere between 0 percent and 100 percent of the binary signal's amplitude, or in other words, arbitrary duty factor data contains DC components. Communication protocols that were developed specifically for use with copper wire often require an optical receiver that is DC coupled or capable of detecting if the data is changing from a high-to-low or low-to-high logic state. That is, the receiver needs to be an edge detector. At relatively modest data rates between zero and 10-Mbits/sec it is possible to construct DC coupled TTL-compatible fiberoptic receivers. The Avago Technologies HFBR-2521Z is a TTL-compatible, DC to 5-Mbit/sec receiver, and the HFBR-2528Z is a DC to 10-Mbit/sec CMOS or TTL-compatible receiver. Additional information about DC to 5-Mbit/sec applications can be found in Avago Technologies AN-1035, and applications support for DC to 10-Mbit/sec applications can be obtained by reading AN-1080. This application note will focus on higher speed or higher performance arbitrary duty factor optical data communication links that work at higher data rates or greater distances than achievable with the HFBR-2521Z or HFBR-2528Z components. The optical transceivers shown in this application note can also be used in burst-mode applications where the data is transmitted in packets and there are no transitions between bursts of data.

The Pros and Cons of Arbitrary Duty Factor or Burst Mode Data

The most important advantage of any existing data communication protocol is that it already exists, and typically works reasonably well with copper wires in many applications. On the other hand, existing protocols for copper wire are usually not the best choice for optimizing the performance of a fiberoptic link. For example, a receiver designed for use with arbitrary duty factor data, or burst mode data, will typically be 4 dB to 7 dB less sensitive than when the same components are used in receiver circuits optimized for use with encoded data. Encoded data normally has a 50 percent duty factor, or restricted duty factor variation, which allows the construction of higher-sensitivity fiberoptic receivers. The best arbitrary duty factor or burst-mode receivers described in this application note are considerably less sensitive than the encoded data receivers described in AN-1122.

When sending arbitrary duty factor data, a separate optical link must be used to send the clock if synchronous serial communication is desired, or an asynchronous data communication system can be implemented if the data is oversampled by a local clock oscillator located

at the receiving end of the fiberoptic data link. To avoid excessive pulsewidth distortion (PWD), the local oscillator used to oversample the received data must operate at frequency that is greater than the serial data rate. For instance, if the data rate is 32-Mbits/sec, a clock frequency of 100 MHz will assure three times oversampling of the received serial data. As the sampling rate decreases, the PWD of the reclocked data increases. Conversely, when the sampling rate is increased, the PWD of the asynchronous data link decreases. At modest data rates such as 32-Mbits/sec the frequency of the local clock oscillator will rise sharply if higher oversampling rates are attempted; for instance, to guarantee five times oversampling the clock oscillator at the receiver would need to operate at a frequency slightly greater than 160 MHz. Refer to Figure 1 for a graphical representation of the relationship between the sampling rate and PWD of an asynchronous serial data communication link.

The 10Base-T copper standard sends no transitions between packets of Ethernet data, but the 10Base-FL standard for optical fiber media inserts a 1 MHz square wave between each packet of Ethernet traffic.

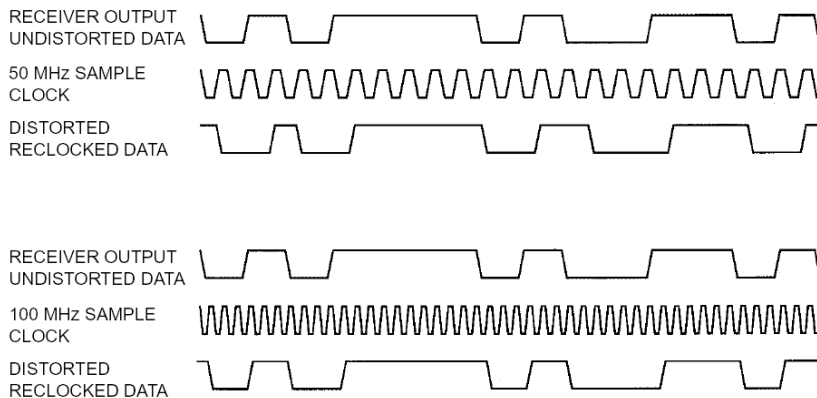
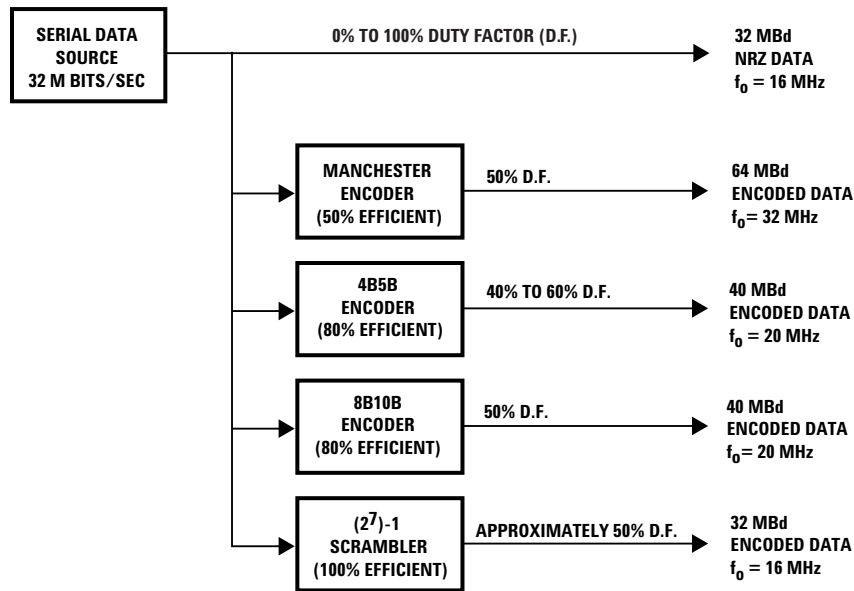

Figure 1. Relationship Between PWD and Sampling Rate



NOTE THAT F_0 IS THE MAXIMUM FUNDAMENTAL FREQUENCY OF THE ENCODED DATA.
 THE MINIMUM FUNDAMENTAL FREQUENCY OF THE ENCODED DATA IS DETERMINED BY THE
 ENCODER'S RUN LIMIT

Figure 2. Attributes of Encoding

Burst-mode serial communication systems also have some interesting characteristics. They usually require more communication channel bandwidth, since the most common burst-mode protocols normally use a Manchester encoder, which transmits more than one symbol for each bit. Figure 2 shows how the communication channel's bandwidth must increase when the Manchester code normally used in Ethernet data communication systems is applied to unencoded serial data. The big advantage of encoding is that it merges the clock and data so that only one communication channel is needed for both signals. In most high-performance fiberoptic communication systems, the data and clock are merged onto a single serial channel using a method that has better efficiency than Manchester encoding. Figure 2 shows several common encoding methods with better efficiency than Manchester code. Other important relationships between bits/second, and symbols/second, expressed in Baud (Bd) are explained by Figure 2. Note that arbitrary duty factor unencoded data is one of the few instances when data rate in bits/second, and the symbol rate in Bd are equal. Relationships between the signaling rate expressed in Baud and the fundamental frequency of digital data communication signals are also shown in Figure 2.

Burst-mode communication protocols are used in popular serial communication systems such as Ethernet, or Arcnet. Burst-mode protocols allow many network users to share a common pair of copper conductors with a tapped connection for each user network interface. The key disadvantages of this simple tapped line

architecture is that only one user can send data at any time, and a preamble must be sent to wake up or initialize the receiving node's timing recovery circuit at the beginning of each packet of burstmode data. Burst-mode, shared-wire communication links are not particularly fast, because no data can be transmitted during the preamble and each node must wait until the tapped line is quiet before data can be transmitted. Burst-mode protocols are not necessarily the best choice for optical communication links, because optical fibers are not easily and inexpensively tapped. When Ethernet traffic is sent via optical fibers, the wiring architecture is changed from a tapped serial transmission line to hubs that contain active fiberoptic transmitters and receivers. The active hubs are then connected to one another in a "star" configuration, because this star architecture is compatible with existing low-cost fiberoptic transceiver and cabling technologies. Fiberoptic receivers can be designed to accommodate burst-mode data, but it is much easier to build highsensitivity fiberoptic receivers when data is sent continuously. Continuous transmission also has other advantages. Continuous transmission increases the throughput of the LAN since there is no dead-time between packets of data. Throughput is substantially improved when data is continuously transmitted, because no time is wasted sending preambles of sufficient length to allow the receiver's timing-recovery circuit to acquire the phase lock required to synchronously detect each serial data packet. It is interesting to note that the IEEE 802.3 10Base-FL standard for fiberoptic media uses a different transmission.

The 1 MHz idle signal described in the IEEE 802.3 10Base-FL standard assures that the burst-mode protocol used for copper wire Ethernet is converted to a protocol that will optimize the performance of a fiberoptic receiver. More details about inexpensive fiberoptic solutions suitable for use with higher-efficiency block substitution codes, such as 4B5B, and 8B10B, can be found in Avago Technologies Application Notes 1122 and 1123. This publication will stay focused on solutions compatible with unencoded data, because many system designers need a fiberoptic solution that can use protocols originally developed for use with copper wires.

Distances and Data Rates Achievable

The simple transceivers recommended in this application note can be used to address a very wide range of distances, data rates, and system cost targets. The maximum distances allowed with various types of optical fiber when using Avago Technologies' wide range of fiberoptic transceiver components are shown Table 1. One simple calculation is needed to optimize the receiver for use at the desired maximum symbol rate of your system application. No transmitter or receiver adjustments are needed when using fiber cable length that vary from virtually zero length up to the maximum distances specified in Table 1.

Table 1

Transmitter Component Part # and Wavelength	Receiver Component Part # and Wavelength	Fiber Diameter Type	Maximum Distance at 32 MBd with the transceiver circuits recommended in this publication
HFBR-15X7Z 650 nm LED	HFBR-25X6Z 650 nm	1 mm plastic step index	27 meters with transmitter in Fig. 3 and receiver in Fig. 4
HFBR-15X7Z 650 nm LED	HFBR-25X6Z 650 nm	1 mm plastic step index	42 meters with transmitter in Fig. 3 and receiver in Fig. 5
HFBR-15X7Z 650 nm LED	HFBR-25X6Z 650 nm	200 μ m HCS step index	690 meters with transmitter in Fig. 3 and receiver in Fig. 4
HFBR-15X7Z 650 nm LED	HFBR-25X6Z 650 nm	200 μ m HCS step index	1.0 kilometer with transmitter in Fig. 3 and receiver in Fig. 5
HFBR-14X2Z 820 nm LED	HFBR-24X6Z 820 nm	200 μ m HCS step index	690 meters with transmitter in Fig. 3 and receiver in Fig. 4
HFBR-14X2Z 820 nm LED	HFBR-24X6Z 820 nm	200 μ m HCS step index	1.0 kilometer with transmitter in Fig. 3 and receiver in Fig. 5
HFBR-14X4Z 820 nm LED	HFBR-24X6Z 820 nm	62.5/125 μ m multimode glass	800 meters with transmitter in Fig. 3 and receiver in Fig. 4
HFBR-14X4Z 820 nm LED	HFBR-24X6Z 820 nm	62.5/125 μ m multimode glass	1.6 kilometers with transmitter in Fig. 3 and receiver in Fig. 5
HFBR-13X2TZ 1300 nm LED	HFBR-23X6TZ 1300 nm	62.5/125 μ m multimode glass	1.3 kilometers with transmitter in Fig 3. and receiver in Fig. 4
HFBR-13X2TZ 1300 nm LED	HFBR-23X6TZ 1300 nm	62.5/125 μ m multimode glass	3.3 kilometers with transmitter in Fig. 3 and receiver in Fig. 5

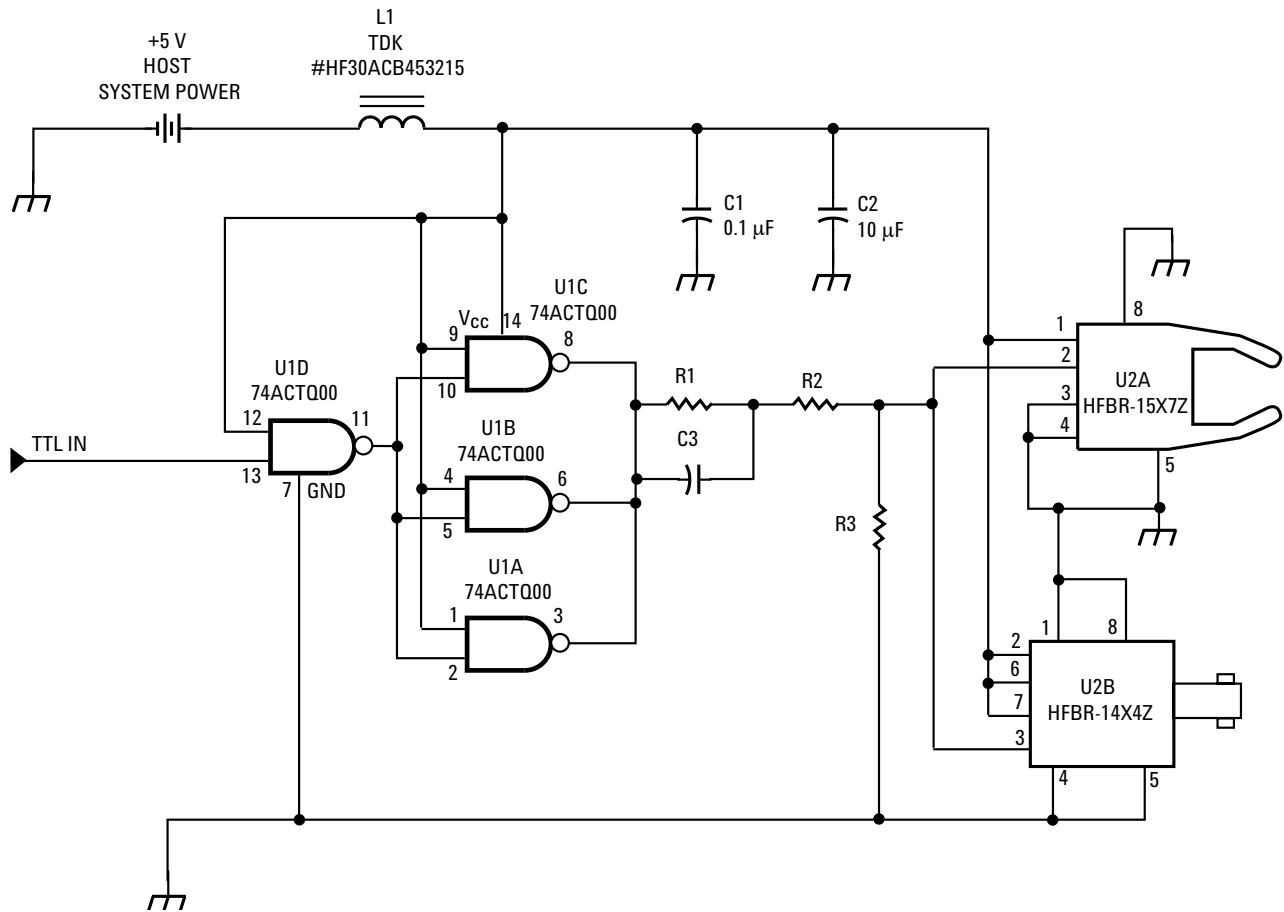

Figure 3. TTL-Compatible LED Transmitter

Table 2

Transmitter	HFBR-15X7Z 650 nm LED	HFBR-14X4Z 820 nm LED	HFBR-13X2TZ 1300 nm LED
Fiber Type	1 mm Plastic	200 μm HCS	62.5/125 μm
R1	120 Ω	33 Ω	33 Ω
R2	120 Ω	33 Ω	27 Ω
R3	390 Ω	270 Ω	∞
C3	82 pF	470 pF	150 pF

Simple TTL Compatible LED Transmitter

A high-performance, low-cost TTL-compatible transmitter is shown in Figure 3. This transmitter recommendation is deceptively simple, but has been highly developed to deliver the best performance achievable with Avago Technologies' LED transmitters. The recommended transmitter is also very inexpensive, because the 74ACTQ00 gate used to current modulate the LED can typically be obtained for under \$0.40. No calculations are required to determine the passive component needed when using various Avago Technologies' LEDs with a wide range of optical fibers. Simply use the

recommended component values shown in Table 2, and the transmitter shown in Figure 3 can be used to address a broad range of applications.

Simple TTL Compatible Receiver

A very simple TTL-compatible receiver that has adequate sensitivity for a wide range of applications is shown in Figure 4. Equation 1 allows the designer to quickly determine the values of C6 and C7 so that the receiver is optimized for operation at any data rate up to a maximum of 32 MBd.

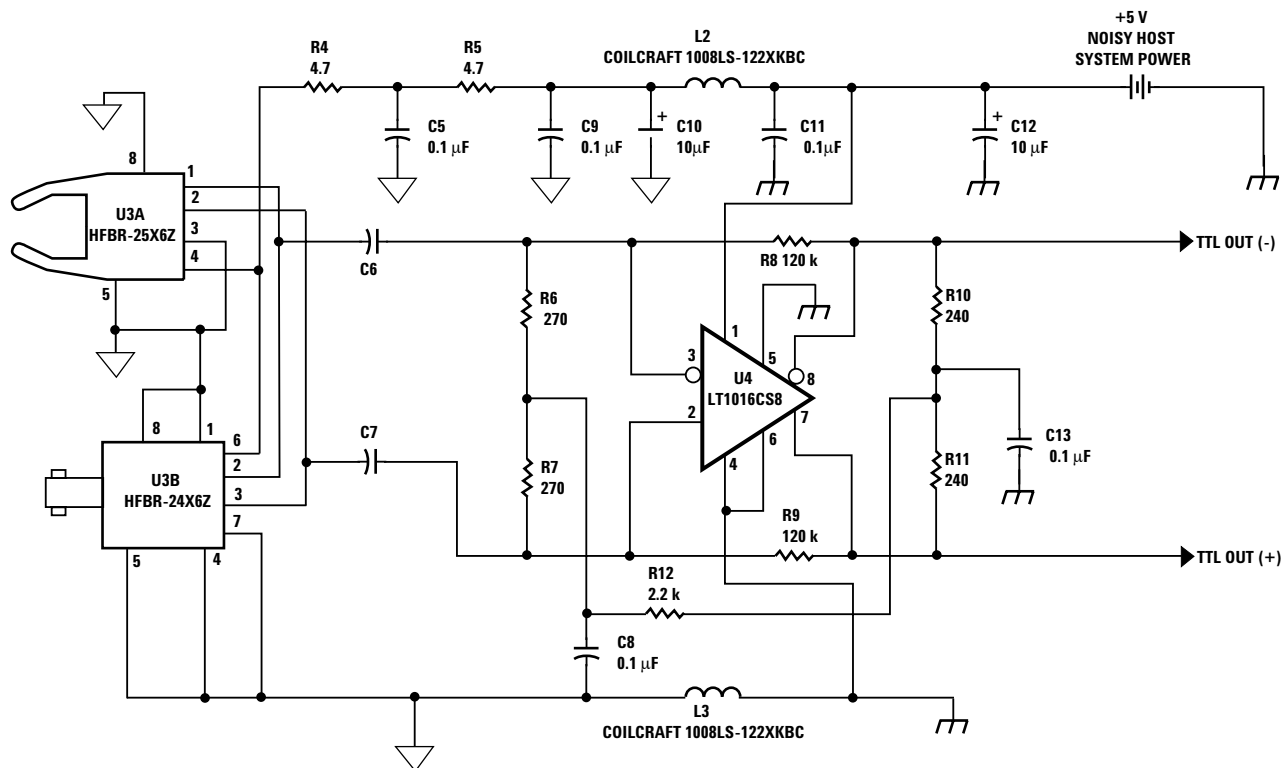

Figure 4. Simple Fiberoptic Receiver for use with DC to 32 MBd Arbitrary Duty Factor Data

Enhanced TTL Compatible Receiver

The receiver circuit shown in Figure 5 is suitable for use in applications that require greater optical cable lengths. The receiver in Figure 5 provides 6 dB more receiver sensitivity than the simplified receiver shown in Figure 4. Equation 2 allows the designer to quickly determine the values of C9 and C10 so that the receiver is optimized for operation at any data rate up to a maximum of 32 MBd.

Printed Circuit Artwork

The performance of transceivers that use Avago Technologies' fiberoptic components are partially dependent on the layout of the printed circuit board on which the transceiver circuits are constructed. System designers are encouraged to embed the printed circuit designs provided in this application note to achieve the fiberoptic link performance described in Table 1. The printed circuit artwork in Figure 6 is for the transmitter in Figure 3 and the receiver in Figure 4. The printed

circuit artwork in Figure 7 is for the transmitter in Figure 3 and the receiver in Figure 5. Electronic copies of the Gerber files for the artwork shown in this application note can be obtained by using the Internet to download the printed circuit designs.

To obtain the artwork for the transmitter shown in Figure 3 and the receiver shown in Figure 4, download file from the following URL: <http://www.avagotech.com>

To obtain the artwork for the transmitter shown in Figure 3 and the receiver shown in Figure 5, download file from the following URL: <http://www.avagotech.com>

Equation 1

$$C6 = C7 = \frac{2}{(3) (R6 + R7) [\text{Data Rate (Bd)}]}$$

Table 3

Receiver	HFBR-25X6Z – 650 nm	HFBR-24X6Z – 820 nm	HFBR-23X6TZ – 1300 nm
Fiber Type	1 mm Plastic	200 μm HCS	62.5/125 μm

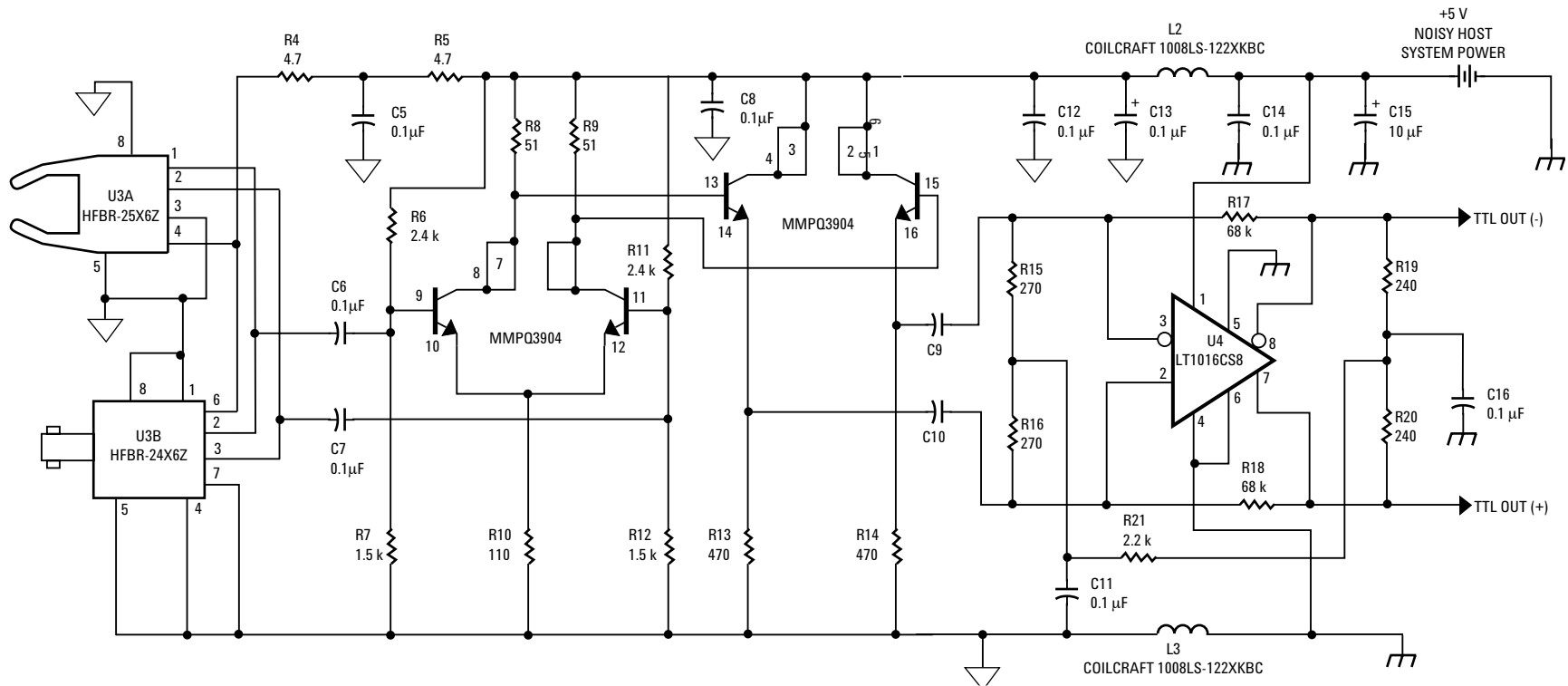

Figure 5. Enhanced Fiberoptic Receiver for use with dc to 32 MBd Arbitrary Duty Factor Data

Equation 2

$$C9 = C10 = \frac{2}{(3) (R15 + R16) [\text{Data Rate (Bd)}]}$$

Table 4

Receiver	HFBR-25X6Z – 650 nm	HFBR-24X6Z – 820 nm	HFBR-23X6TZ – 1300 nm
Fiber Type	1 mm Plastic	200 μm HCS	62.5/125 μm

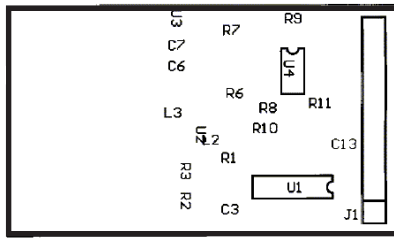

Figure 6a. Top Overlay

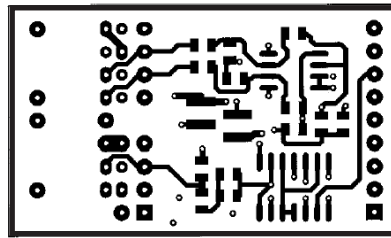

Figure 6b. Top Layer

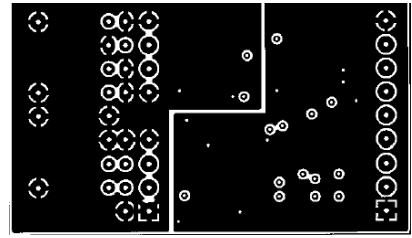

Figure 6c. Mid layer

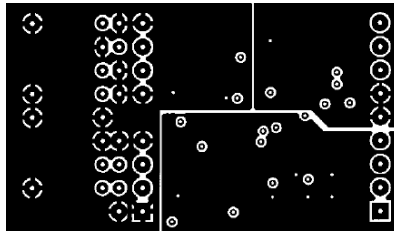

Figure 6d. Mid Layer

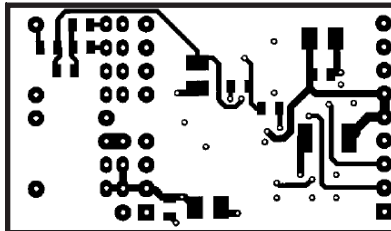

Figure 6e. Bottom Layer

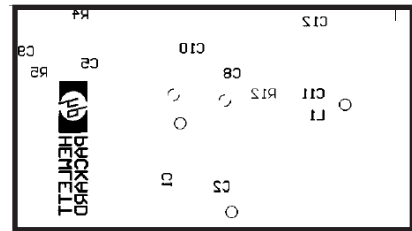

Figure 6f. Bottom Layer

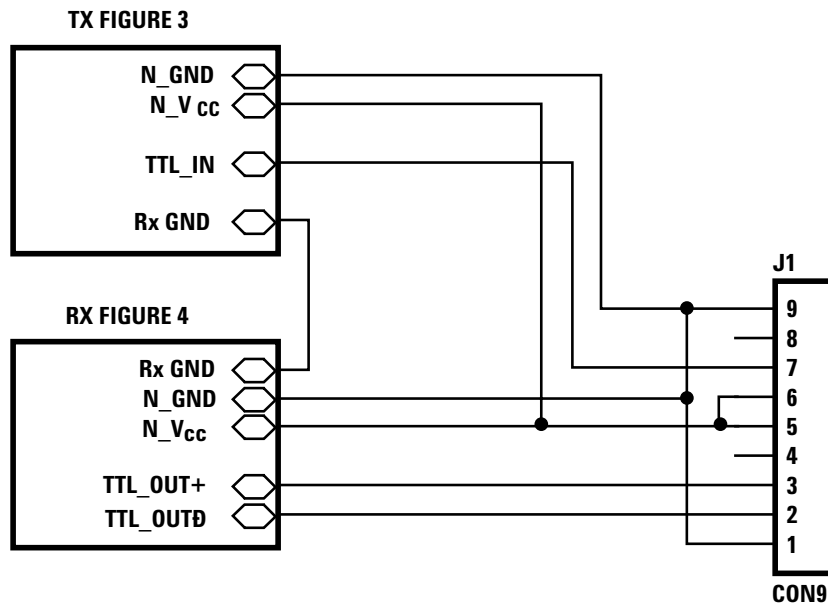

Figure 6g. Transmitter 1 Schematic

Figure 6. Printed Circuit Artwork for Transmitter shown in Figure 3 and Receiver in Figure 4

WARNING: DO NOT USE PHOTOCOPIES OR FAX COPIES OF THIS ARTWORK TO FABRICATE PRINTED CIRCUITS.

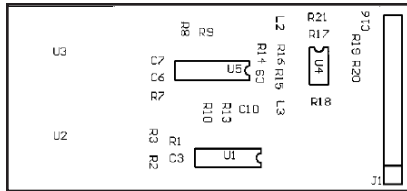

Figure 7a. Top Overlay

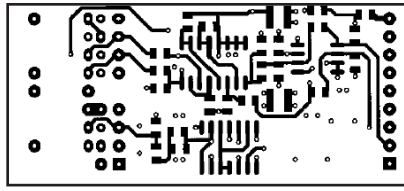

Figure 7b. Top Layer

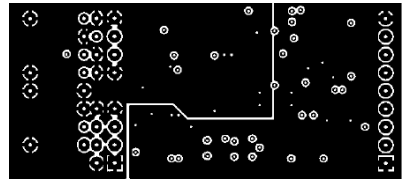

Figure 7c. Mid Layer 2

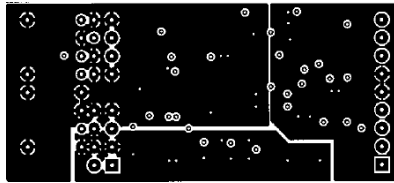

Figure 7d. Mid layer 3

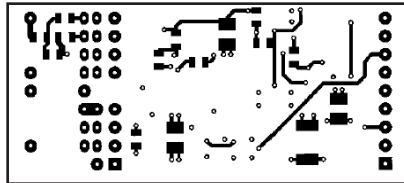

Figure 7e. Bottom Layer

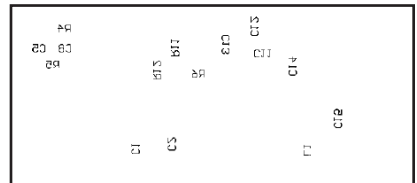

Figure 7f. Bottom Overlay

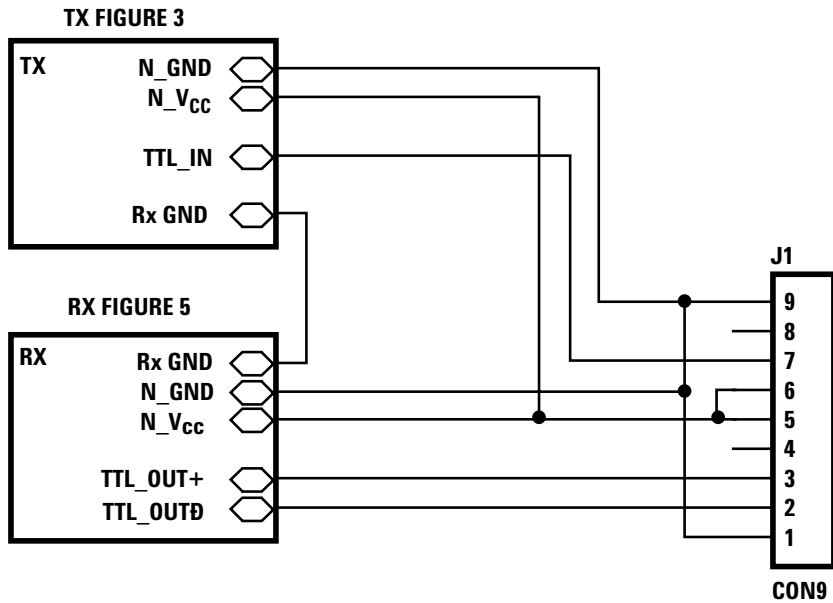

Figure 7g. Transmitter 2 Schematic

WARNING: DO NOT USE PHOTOCOPIES OR FAX COPIES OF THIS ARTWORK TO FABRICATE PRINTED CIRCUITS.

Figure 7. Printed Circuit Artwork for Transmitter in Figure 3 and Receiver in Figure 5

Error Rates and Noise Immunity

The probability that a fiberoptic link will make an error is related to the receiver's own internal random noise and its ability to reject noise originating from the system in which it is installed. The total noise present in any fiberoptic receiver is normally the sum of the PIN diode preamplifier's noise and the host system's electrical noise. The amount of hysteresis applied to the comparator determines the minimum signal amplitude (also known as minimum signal threshold level) at which the receiver can reliably detect data. The ratio between the comparator's switching threshold (also known as hysteresis) and the receiver's noise also has a dramatic impact on probability of error. Small increases in the comparator's threshold-to-noise ratio result in a very sharp reduction in the probability of error. Figure 8 shows that the receiver's probability of error is reduced by six orders of magnitude from 1×10^{-9} to 1×10^{-15} when the receiver's threshold-to-noise ratio improves from 12:1 to 15.8:1. At any fixed temperature the total value of the receiver's random noise plus the host system's noise can be assumed to be a constant. So the most obvious way to reduce the probability of error is to increase the comparator's hysteresis and increase the amplitude of the optical signal applied to the receiver. A less obvious but better technique for lowering the error rate is to improve the receiver's ability to reject electrical noise from the system in which it resides. The fiberoptic receivers recommended in this application note have sufficient noise immunity to be used in most systems without electrostatic shielding. The Avago Technologies PIN diode pre-amps, which are used in the receiver's first stage, are small hybrid circuits, and these small hybrid components do not function as particularly effective antennas. For extremely noisy applications, Avago Technologies offers PIN diode pre-amps in electrically conductive plastic or all metal packages. Avago Technologies manufactures a wide range of conductive and non-conductive fiberoptic components that mate with various industry-standard fiberoptic connectors. However, the overwhelming majority of the fiberoptic applications successfully implemented with Avago Technologies' fiberoptic components have not required conductive plastic or metal receiver housings. The most insidious and the most overlooked source of noise is

usually the host system's +5 V power supply. The host system's +5 volt supply normally powers the fiberoptic receiver, the fiberoptic transmitter and an entire system comprised of relatively noisy digital circuits. The simple and inexpensive power supply filters recommended in this publication have been proven to work in a wide range of system applications. The power-supply filters recommended in this application note are normally sufficient to protect the fiberoptic receiver from very noisy host systems, but in extremely noisy applications additional power supply filtering could be needed.

Parts List

The TTL-compatible fiberoptic transceivers recommended in this publication are very simple and inexpensive, so only a few external components are needed. Complete parts lists for the circuits recommended in this application note are provided in Table 5 and Table 6. The parts listed in Table 5 are for the transmitter in Figure 3 and the receiver in Figure 4. The parts listed in Table 6 are for the transmitter in Figure 3 and the receiver in Figure 5. All of the components described in the part lists are compatible with the printed circuit artworks shown in Figure 6 and Figure 7, thus minimizing the design time and resources needed to use the low cost fiberoptic transceivers shown in the application note.

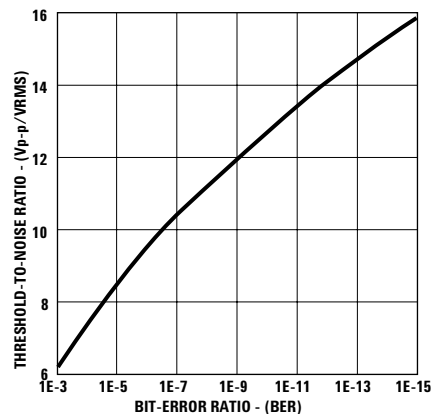

Figure 8. Receiver Threshold-to-Noise Ratio vs. Probability of Error (aka BER)

Conclusion

The complete TTL-compatible fiberoptic transceiver solutions provided in this publication can be used to improve the noise immunity of existing data communication systems that use protocols originally developed for use with copper wire. When fiberoptic media is used in place of conventional copper wire, it is possible to build new communication systems that are immune to large noise transients caused by utility power switch gear, motor drives or high voltage power supplies. Furthermore the non-conductive cables used in optical

communication links have an intrinsically higher probability of surviving lightning strikes than copper wire alternatives. The optical data communication solutions shown in this application note are also capable of sending highspeed 32 MBd data over long distances that would be impractical with copper wire cables. System designers can quickly develop noise-immune communication links with minimal engineering costs by embedding the complete fiberoptic solution shown in this application note.

Table 5. Parts List for the Transmitter in Figure 3 and Receiver in Figure 4

Designator	Part Type	Description	Footprint	Material	Part Number	Quantity	Vendor 1
C1	0.1 μ F	Capacitor	805	X75 or better	C0805X7R500104KNE	6	Venkel
C5	0.1 μ F	Capacitor					
C8	0.1 μ F	Capacitor					
C9	0.1 μ F	Capacitor					
C11	0.1 μ F	Capacitor					
C13	0.1 μ F	Capacitor					
C6	Determined	Capacitor	805	NPO/COG		1	Venkel
C7	by Equation 1	Capacitor	805	NPO/COG		1	
C2	10 μ F	Capacitor	B	Tantalum, 10V	TA010TCM106MBN	3	Venkel
C10	10 μ F	Capacitor					
C12	10 μ F	Capacitor					
C3	See Table 2	Capacitor	805	NPO/COG		1	Venkel
U1	I.C.	Nand Gate	S014		74ACTQ00	1	Fairchild
U2	Fiberoptic	Transmitter		See Table 2	HFBR-1XXXZ	1	Avago Technologies
U3	Fiberoptic	Receiver		See Table 4	HFBR-2XXXZ	1	Avago Technologies
U4	LT1016	IC, comparator	S08		LT1016CS8	1	Linear Tech
L1	CB70-1812	Inductor	1812		HF30ACB453215	1	TDK
L2	1.2 μ H	Inductor		10%	1008LS-122XKBC	2	Coilcraft
L3							
R4	4.7 Ω	Resistor	805	5%	CR080510W4R7JT	2	Venkel
R5	4.7 Ω	Resistor					
R1	See Table 2	Resistor	805	1%		1	Venkel
R2	See Table 2	Resistor	805	1%		1	Venkel
R3	See Table 2	Resistor	805	1%		1	Venkel
R6	270 Ω	Resistor	805	5%	CR080510W271JT	2	Venkel
R7	270 Ω						
R8	120 k Ω	Resistor	805	5%	CR080510W241JT	2	Venkel
R9	120 k Ω						
R10	240 Ω	Resistor	805	5%	CR080510W241JT	2	Venkel
R11	240 Ω						
R12	2.2 k Ω	Resistor	805	5%	CR080510W222JT	1	Venkel
J1		Pins		343B	9		McKenzie

Table 6. Parts List for the Transmitter in Figure 3 and Receiver in Figure 5

Designator	Part Type	Description	Footprint	Material	Part Number	Quantity	Vendor 1
C1	0.1 μ F	Capacitor	805	X7R or Better	C0805X7R500104KNE	8	Venkel
C6	0.1 μ F	Capacitor					
C7	0.1 μ F	Capacitor					
C8	0.1 μ F	Capacitor					
C11	0.1 μ F	Capacitor					
C12	0.1 μ F	Capacitor					
C14	0.1 μ F	Capacitor					
C16	0.1 μ F	Capacitor					
C9	Determined by Equation 2	Capacitor	805	NPO/COG		1	Venkel
C10		Capacitor	805	NPO/COG		1	Venkel
C2	10 μ F	Capacitor	B	Tantalum, 10V	TA010TCM106MBN	3	Venkel
C13	10 μ F	Capacitor					
C15	10 μ F	Capacitor					
C3	See Table 2	Capacitor	805	NPO/COG		1	Venkel
U1	I.C.	Nand Gate	5014		74ACTQ00	1	Fairchild
U2	Fiberoptic	Transmitter		See Table 2	HFBR-1XXXZ	1	Avago Technologies
U3	Fiberoptic	Receiver		See Table 4	HFBR-2XXXZ	1	
U4	LT1016	IC, comparator	508		LT1016CS8	1	Linear Tech
U5	Quad NPN	Transistor	5016		MMPQ3904	1	Motorola
L1	CB70-1812	Inductor	1812		HF30ACB453215	1	TDK
L2	1.2 μ H	Inductor		10%	108LS-122XKBC	2	Coilcraft
L3							
R4	4.7 Ω	Resistor	805	5%	CR080510W4R7JT	2	Venkel
R5	4.7 Ω	Resistor					
R1	See Table 2	Resistor	805	1%		1	Venkel
R2	See Table 2	Resistor	805	1%		1	Venkel
R3	See Table 2	Resistor	805	1%		1	Venkel
R6	2.4 k Ω	Resistor	805	5%	CR080510W242JT	2	Venkel
R11	2.4 k Ω						
R7	1.5 k Ω	Resistor	805	5%	CR080510W152JT	2	Venkel
R12	1.5 k Ω						
R8	51 Ω	Resistor	805	5%	CR080510W510JT	2	Venkel
R9	51 Ω						
R10	110 Ω	Resistor	805	5%	CR080510W111JT	1	Venkel
R13	470 Ω	Resistor	805	5%	CR080510W471JT	2	Venkel
R14	470 Ω						
R15	270 Ω	Resistor	805	5%	CR080510W271JT	2	Venkel
R16	270 Ω						
R17	68 k Ω	Resistor	805	5%	CR080510W163JT	2	Venkel
R18	68 k Ω						
R19	240 Ω	Resistor	805	5%	CR080510W241JT	2	Venkel
R20	240 Ω						
R21	2.2 k Ω	Resistor	805	5%	CR080510W222JT	1	Venkel
J1		Pins			343B	9	McKenzie

For product information and a complete list of distributors, please go to our web site: www.avagotech.com

Avago, Avago Technologies, and the A logo are trademarks of Avago Technologies in the United States and other countries.
Data subject to change. Copyright © 2005-2010 Avago Technologies. All rights reserved.
AV02-0723EN - July 22, 2010

