



Chipsmall Limited consists of a professional team with an average of over 10 year of expertise in the distribution of electronic components. Based in Hongkong, we have already established firm and mutual-benefit business relationships with customers from,Europe,America and south Asia,supplying obsolete and hard-to-find components to meet their specific needs.

With the principle of “Quality Parts,Customers Priority,Honest Operation,and Considerate Service”,our business mainly focus on the distribution of electronic components. Line cards we deal with include Microchip,ALPS,ROHM,Xilinx,Pulse,ON,Everlight and Freescale. Main products comprise IC,Modules,Potentiometer,IC Socket,Relay,Connector.Our parts cover such applications as commercial,industrial, and automotives areas.

We are looking forward to setting up business relationship with you and hope to provide you with the best service and solution. Let us make a better world for our industry!



Contact us

Tel: +86-755-8981 8866 Fax: +86-755-8427 6832

Email & Skype: info@chipsmall.com Web: www.chipsmall.com

Address: A1208, Overseas Decoration Building, #122 Zhenhua RD., Futian, Shenzhen, China



Product Specification

8 Gbps 850nm PIN + Preamp LC ROSA Package

HFD7180-001

PRODUCT FEATURES

- LC ROSA package
- High performance GaAs PIN photodiode with separate transimpedance amplifier
- Low electrical parasitic TO46 package
- Data rates up to 8.5Gbps
- Separate detector bias pin can be used for receive
- power monitoring
- Low power dissipation
- Can drive SERDES directly
- RoHS compliant (EU Directive on Restrictions of Hazardous Substances, 2002/95/EC)



The HFD7180-001 uses a high-performance GaAs PIN photo-detector packaged with a transimpedance amplifier designed to meet performance requirements for 8Gbps data communication over multi-mode optical fiber at 850nm. Applications include Ethernet, Fiber Channel and ATM protocols. The optical assembly is designed to interface either 50mm or 62.5mm multi-mode fiber.

The HFD7180-0011 is designed to be paired with Advanced Optical Components HFE7192 VCSEL 8Gbps TOSA products (see data sheets for HFE7192 products at www.finisar.com/).

PRODUCT SELECTION

Part Number	Description
HFD7180-001	LC ROSA, with separate PD bias

I. Absolute Maximum Ratings

Parameter	Rating
Storage Temperature	-40 to +95°C
Case Operating Temperature	-20 to +95°C
Lead Solder Temperature	260°C, 10 sec.
Power Supply Voltage	-0.3V to 3.6V
PIN Voltage	10V
Incident Optical Power	+3 dBm average, +6 dBm peak
ESD Exposure (Human Body Model)	225V

Notice

Stresses greater than those listed under “Absolute Maximum Ratings” may cause permanent damage to the device. This is a stress rating only and functional operation of the device at these or any other conditions above those indicated in the operations section for extended periods of time may affect reliability.

Notice

The inherent design of this component causes it to be sensitive to electrostatic discharge (ESD). To prevent ESD-induced damage and/or degradation to equipment, take normal ESD precautions when handling this product

II. Electro-Optical Characteristics (Vcc =3.3V, AC coupled to 50W (100W differential), -20°C < TA <95°C unless otherwise specified)

Parameters	Test Condition	Symbol	Min.	Typ.	Max.	Units	Notes
Data Rate		DR			8.5	Gbps	1
Input Optical Wavelength	0°C to 70°C	λ_p	830	850	870	nm	
Supply Voltage			2.97	3.3	3.63	V	
Supply Current	$P_R=0\mu W$, $R_L=50\Omega$ AC coupled	I_{CC}		35	50	mA	
PD Bias Voltage		VPD_Bias	3	3.3	3.6	V	
Photodiode Responsivity	$P_R=-12\text{dBm}$	Resp	0.45	0.5	0.6	A/W	
Active Area (diameter)				40		μm	
Optical Return Loss	$P_R=-12\text{dBm}$	ORL	12			dB	
Differential Output Voltage Swing	$P_{R,OMA}=-12\text{Bm}$, AC Coupled to $R_L=50\Omega$	$V_{o(pk-pk)}$	150	260	330	mV	2,3
Differential Responsivity	$P_{R,OMA}=-12\text{dBm}$, AC Coupled to $R_L=50\Omega$	T	2300	3000	5300	V/W	2,3
-3dB Optical/Electrical Bandwidth	$P_{R,OMA}=-12\text{dBm}$ Temp = 25°C	BW	6	7.5	11	GHz	2,3
Low Frequency -3dB Cutoff	$P_{R,OMA}=-12\text{dBm}$	BW_{LF}			90	KHz	2,3
Output Impedance		Z_{OUT}	40	50	60	Ω	
Sensitivity, OMA	DR = 2.125Gbps	S		-19	-16	dBm	4
	DR = 4.25Gbps			-18	-15		
	DR = 8.5Gbps			-15	-13		
Rise/Fall Time	$P_{R,OMA}=-12\text{dBm}$, (20%-80%)	T_R/T_F		30	50	ps	2,5
Group Delay	Measured from S21 Phase	GVD	-50		50	ps	7
Power Supply Rejection Ratio	$P_R=0\mu W$ (Dark), Freq = 1000MHz	PSRR	20			dB	1,6
Deterministic Jitter	PR,OMA=-12dBm RL=50 Ω AC	DJTIA		20	40	ps	8
Random Jitter	PR,OMA=-12dBm RL=50 Ω AC	RJTIA		3	5	Ps	9

Notes:

1. P_R is the average optical power at the fiber face.
2. $P_{R,OMA}$ is the peak to peak optical power at the fiber face (Optical Modulation Amplitude)

$$P_{R,OMA} = \frac{2P_R(ER-1)}{ER+1}$$

where ER is the extinction ratio (linear) of the optical source.

3. Bandwidth and Low Frequency Cutoff are measured with a small signal sinusoidal light source with -10dBm average power
4. Sensitivity is measured with an optical source with an extinction ratio of 3dB. For sensitivity measurements at 2 and 4Gbps, bandwidth limiting of the TIA is assumed to be implemented at the front end of the post amplifier.
5. Rise/Fall times are corrected for optical source Rise/Fall times. $T_{TIA}^2 = T_{MEASURED}^2 - T_{OPTICAL}^2$
6. Value shown is with no external power supply filtering.
7. Group delay is a sensitive measurement to package interface, and includes the effects of PD, TIA and package. Measurement is made with TO leads as short as possible.
8. DJTIA is specified as contributed DJ by the TIA, obtained from $DJ_{tia}^2 = DJ_{total}^2 - DJ_{optical}^2$
9. RJTIA is specified as contributed DJ by the TIA, obtained from $RJ_{tia}^2 = RJ_{total}^2 - RJ_{optical}^2$

- The electrical performance of the ROSA is dependent upon the quality of the electrical connection between the TO can and the circuit board. AOC cannot guarantee all performance specifications for parts without the flex circuit attached.

III. Recommended interface circuit for the HFD6180-421

Optional RSSI implementation is shown in blue.

Optional 100Ω differential termination for high impedance limiting amplifiers is shown in red.

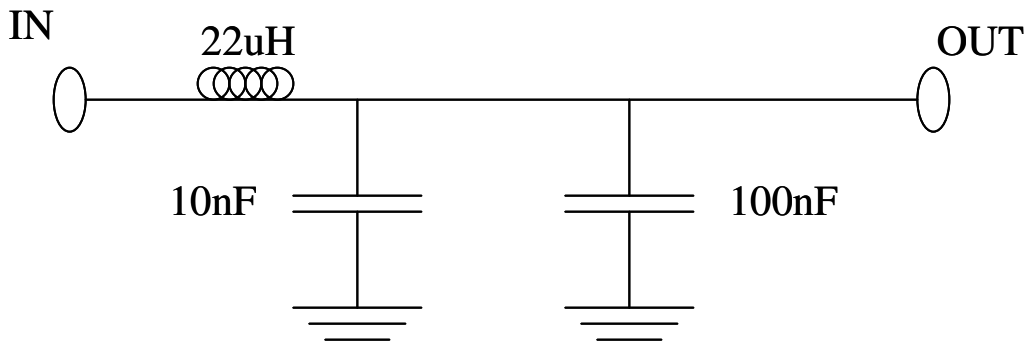
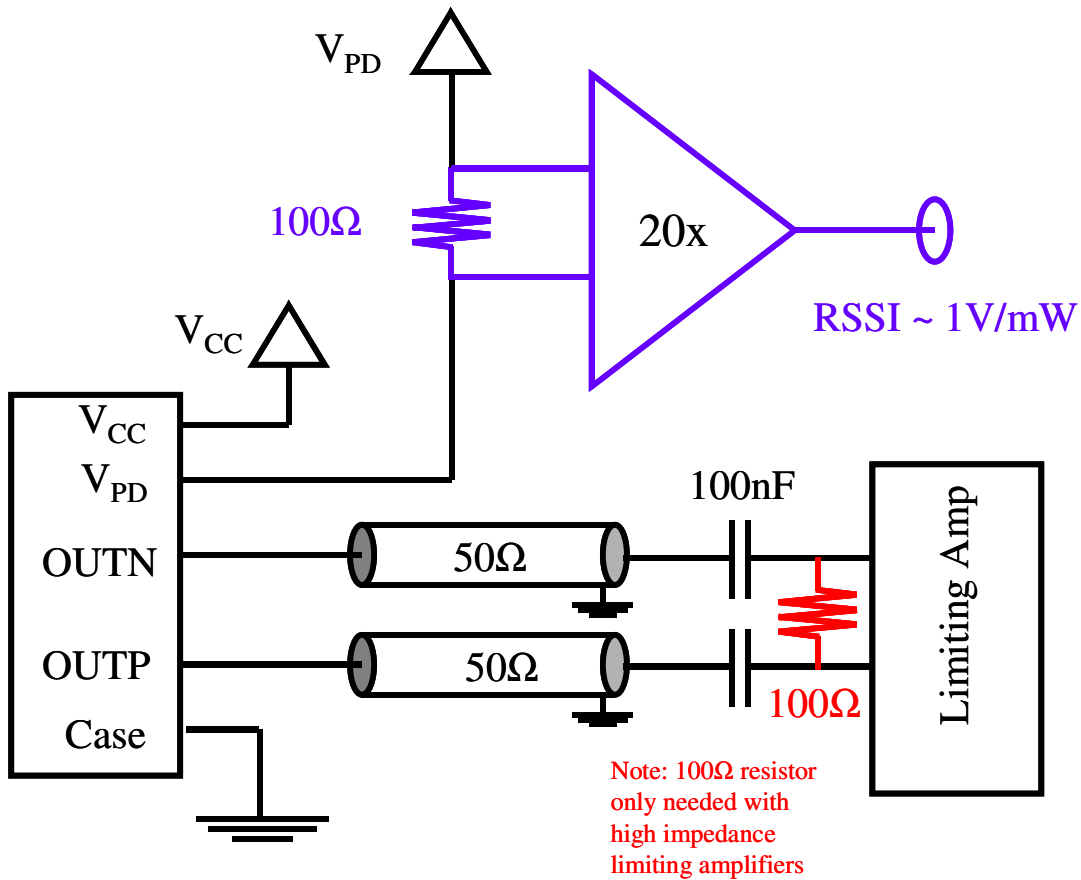

IV. Environmental Specifications

Parameter	Symbol	Min	Typ	Max	Units	Ref.
Case Operating Temperature	T _{op}	-20		95	°C	
Storage Temperature	T _{sto}	-40		95	°C	

V. Mechanical Specifications

PIN	Description
1	Case
2	OUTN
3	V _{cc}
4	V _{PD}
5	OUTP

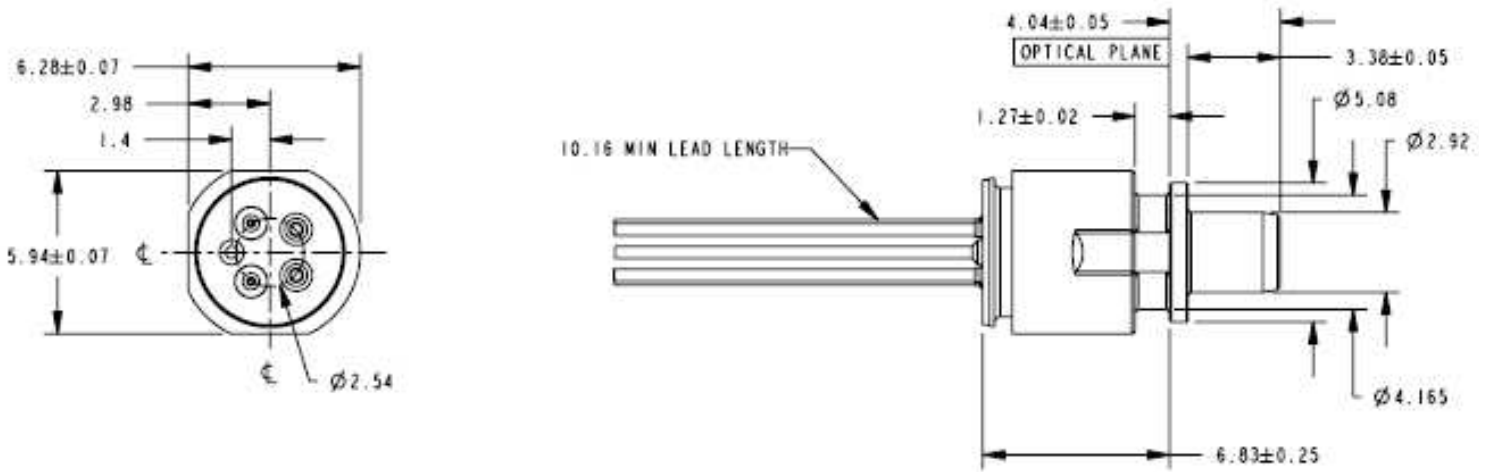

(dimensions are in mm)

VI. Revision History

Revision	Date	Description
B00	10/6/2014	• Changed to Standard Finisar Format.

VII. For More Information

Finisar Corporation
1389 Moffett Park Drive
Sunnyvale, CA 94089-1133
Tel. 1-408-548-1000
Fax 1-408-541-6138
sales@finisar.com
www.finisar.com