



Chipsmall Limited consists of a professional team with an average of over 10 year of expertise in the distribution of electronic components. Based in Hongkong, we have already established firm and mutual-benefit business relationships with customers from,Europe,America and south Asia,supplying obsolete and hard-to-find components to meet their specific needs.

With the principle of "Quality Parts,Customers Priority,Honest Operation,and Considerate Service",our business mainly focus on the distribution of electronic components. Line cards we deal with include Microchip,ALPS,ROHM,Xilinx,Pulse,ON,Everlight and Freescale. Main products comprise IC,Modules,Potentiometer,IC Socket,Relay,Connector.Our parts cover such applications as commercial,industrial, and automotives areas.

We are looking forward to setting up business relationship with you and hope to provide you with the best service and solution. Let us make a better world for our industry!



Contact us

Tel: +86-755-8981 8866 Fax: +86-755-8427 6832

Email & Skype: info@chipsmall.com Web: www.chipsmall.com

Address: A1208, Overseas Decoration Building, #122 Zhenhua RD., Futian, Shenzhen, China



Description

The HIP2100 General Purpose Design Tool is a very simple evaluation board which can help the user rapidly construct an isolated DC/DC converter in numerous configurations. The board consists of the Intersil HIP2100 Half-Bridge Driver IC, two Intersil IRFR120 MOSFETs, a bootstrap capacitor, and two input voltage decoupling capacitors. The HIP2100 can operate at frequencies exceeding 1MHz and has propagation delay times in the 20ns range. It has 2A drive capability which allows it to drive an IRFR120 load with switching times of less than 10ns.

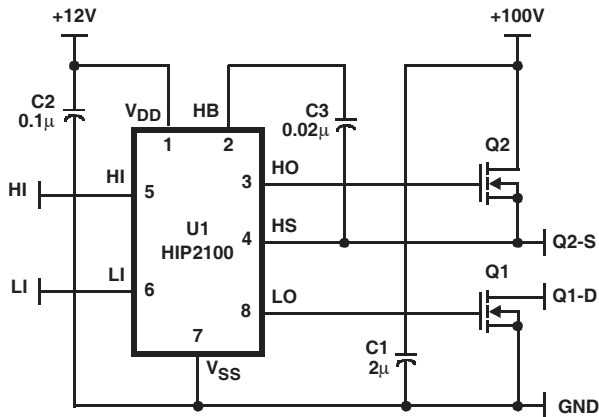

FIGURE 1. HIP2100EVAL SCHEMATIC

Application Information

The HIP2100 General Purpose Design Tool (HIP2100EVAL) is intended for users who have some experience in power converter design. The 100V rating of the HIP2100 makes it an ideal choice for many isolated DC/DC converters which are point-of-load converters in a distributed power architecture. The node labeled "+100V" on the schematic, as well as on the board itself, is the maximum voltage rating of the HS node of the HIP2100. Therefore, depending upon the application, the maximum input voltage that one would apply to the "+100V" input could be less than 100VDC. Three possible application converters are described briefly below.

Application #1: Two-Switch Forward Converter

To use the HIP2100EVAL as part of a two-switch forward converter, the user needs the configuration depicted in Figure 2. In this topology, both MOSFETs are turned on and off together. Therefore, HI and LI are tied together. The signal PWM is from the pulse-width modulator (PWM) controller, which is sensing the output voltage (and output current if current-mode control is used). The Schottky rectifiers clamp the reverse swing of the power transformer and must be rated at the input voltage. The +100V input could be the full 100VDC in this circuit.

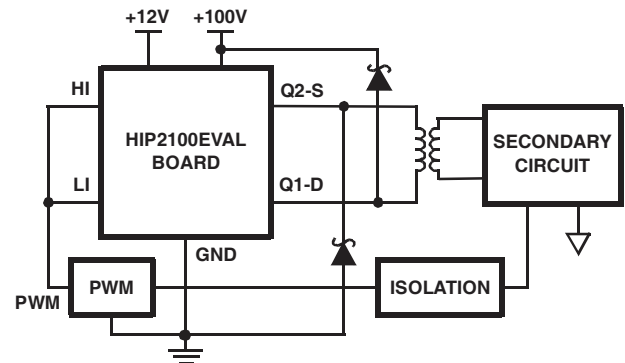

FIGURE 2. TWO SWITCH FORWARD CONVERTER

Application #2: Half-Bridge Converter

To use the HIP2100EVAL as part of a half-bridge converter, the user needs the configuration depicted in Figure 3. In this topology, the MOSFETs are driven alternately (with some dead time between turn-off of one and turn-on of the other). Therefore, HI and LI are driven with alternating signals PWM_A and PWM_B from the PWM controller. The +100V input could also be the full 100VDC in this application.

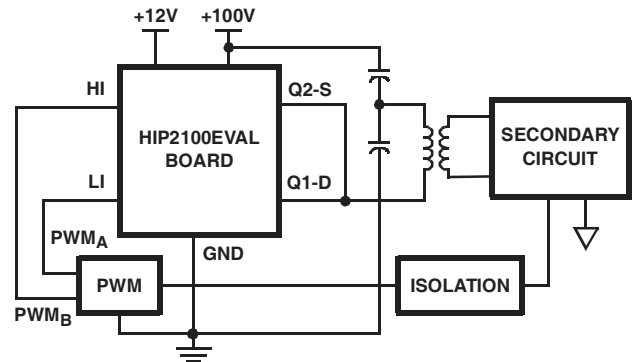

FIGURE 3. HALF-BRIDGE CONVERTER

Application #3: Active-Clamp Forward Converter

To use the HIP2100EVAL as part of an active-clamp forward converter, the user needs the configuration depicted in Figure 4. In this topology, the MOSFETs are again driven alternately, and HI and LI again need to be driven separately. The high-side MOSFET (Q2 in the HIP2100EVAL board), along with capacitor C_{RESET}, is used in this topology as a means to reset the power transformer in a lossless manner. This topology lends itself well to running at duty cycles exceeding 50% (unlike Applications 1 and 2). For these reasons, the +100V input may not be able to except the full 100VDC input for this application.

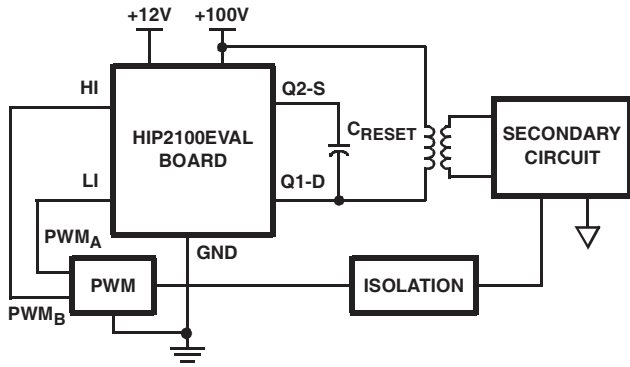

FIGURE 4. ACTIVE-CLAMP FORWARD CONVERTER

Additional Information

The applications highlighted above are three possible DC/DC converter topologies where the HIP2100 half-bridge driver can help simplify the design procedure and provide value to the designer and the end user. There are many other possible applications. More detailed information regarding the HIP2100 can be found in the Intersil data sheet, HIP2100, 100V/2A Peak, Low Cost, High Frequency Half-Bridge Driver, file number 4022.

HIP2100EVAL Parts List

| ITEM | QUANTITY | REFERENCE DESIGNATOR | DESCRIPTION | VENDOR | PART NUMBER |
|----------|----------|----------------------|---------------------------------|----------|----------------|
| 1 | 1 | U1 | Half-Bridge FET Driver | Intersil | HIP2100 |
| 2 | 2 | Q1, Q2 | 100V N-Channel MOSFET | Intersil | IRFR120 |
| 3 | 1 | C1 | 2 μ F, 100V, Ceramic Cap | AVX | 22251C205ZATMA |
| 3 (Note) | 1 | C1 | 0.47 μ F, 100V, Ceramic Cap | AVX | 22251C474MATMA |
| 4 | 1 | C2 | 0.1 μ F, 25V, Ceramic Cap | AVX | 12063E104MATMA |
| 5 | 1 | C3 | 0.022 μ F, 25V, Ceramic Cap | AVX | 12063E223MATMA |
| 6 | 1 | N/A | HIP2100EVAL PCB | Intersil | HIP2100_EVAL |

NOTE: Can be used for item #3.

All Intersil products are manufactured, assembled and tested utilizing ISO9000 quality systems. Intersil Corporation's quality certifications can be viewed at www.intersil.com/design/quality

Intersil products are sold by description only. Intersil Corporation reserves the right to make changes in circuit design, software and/or specifications at any time without notice. Accordingly, the reader is cautioned to verify that data sheets are current before placing orders. Information furnished by Intersil is believed to be accurate and reliable. However, no responsibility is assumed by Intersil or its subsidiaries for its use; nor for any infringements of patents or other rights of third parties which may result from its use. No license is granted by implication or otherwise under any patent or patent rights of Intersil or its subsidiaries.

For information regarding Intersil Corporation and its products, see www.intersil.com

Sales Office Headquarters

NORTH AMERICA
 Intersil Corporation
 7585 Irvine Center Drive
 Suite 100
 Irvine, CA 92618
 TEL: (949) 341-7000
 FAX: (949) 341-7123

Intersil Corporation
 2401 Palm Bay Rd.
 Palm Bay, FL 32905
 TEL: (321) 724-7000
 FAX: (321) 724-7946

EUROPE
 Intersil Europe Sarl
 Ave. C - F Ramuz 43
 CH-1009 Pully
 Switzerland
 TEL: +41 21 7293637
 FAX: +41 21 7293684

ASIA
 Intersil Corporation
 Unit 1804 18/F Guangdong Water Building
 83 Austin Road
 TST, Kowloon Hong Kong
 TEL: +852 2723 6339
 FAX: +852 2730 1433