



Chipsmall Limited consists of a professional team with an average of over 10 year of expertise in the distribution of electronic components. Based in Hongkong, we have already established firm and mutual-benefit business relationships with customers from,Europe,America and south Asia,supplying obsolete and hard-to-find components to meet their specific needs.

With the principle of “Quality Parts,Customers Priority,Honest Operation,and Considerate Service”,our business mainly focus on the distribution of electronic components. Line cards we deal with include Microchip,ALPS,ROHM,Xilinx,Pulse,ON,Everlight and Freescale. Main products comprise IC,Modules,Potentiometer,IC Socket,Relay,Connector.Our parts cover such applications as commercial,industrial, and automotives areas.

We are looking forward to setting up business relationship with you and hope to provide you with the best service and solution. Let us make a better world for our industry!



## Contact us

Tel: +86-755-8981 8866 Fax: +86-755-8427 6832

Email & Skype: info@chipsmall.com Web: www.chipsmall.com

Address: A1208, Overseas Decoration Building, #122 Zhenhua RD., Futian, Shenzhen, China



# 60V, 1A/2A Peak, Half Bridge Driver with 4V UVLO

## HIP2103, HIP2104

The HIP2103 and HIP2104 are half bridge drivers designed for applications using DC motors, three-phase brushless DC motors, or other similar loads.

Two inputs (HI and LI) are provided to independently control the high side driver (HO) and the low side driver (LO). Furthermore, the two inputs can be configured to enable/disable the device, thus lowering the number of connections to a microcontroller and lowering costs.

The very low  $I_{DD}$  bias current in the Sleep Mode prevents battery drain when the device is not in use, thus eliminating the need for an external switch to disconnect the driver from the battery.

A fail-safe mechanism is included to improve system reliability and to minimize the possibility of catastrophic bridge failures due to controller malfunction. Internal logic prevents both outputs from turning on simultaneously when HI and LI are both high simultaneously. Dead-time is still required on the rising edge of the HI (or LI) input when the LI (or HI) input transitions low.

Integrated pull-down resistors on all of the inputs (LI, HI, VDen and VCen) reduces the need for external resistors. An active low resistance pull-down on the LO output ensures that the low side bridge FET remains off during the Sleep Mode or when VDD is below the undervoltage lockout (UVLO) threshold.

The HIP2104 has a 12V linear regulator and a 3.3V linear regulator with separate enable pins. The 12V regulator provides internal bias for VDD and the 3.3V regulator provides bias for an external microcontroller (and/or other low voltage ICs), thus eliminating the need for discrete LDOs or DC/DC converters.

The HIP2103 is available in a 3x3mm, 8 Ld TDFN package and the HIP2104 is available in a 4x4mm, 12 Ld DFN package.

## Features

- 60V maximum bootstrap supply voltage
- 3.3V and 12V LDOs with dedicated enable pins (HIP2104)
- 5 $\mu$ A sleep mode quiescent current
- 4V undervoltage lockout
- 3.3V or 5V CMOS compatible inputs with hysteresis
- Integrated bootstrap FET (replaces traditional boot strap diode)

## Applications

- Half bridge, full bridge and BLDC motor drives (see Figures 21, 22, 23)
- UPS and inverters
- Class-D amplifiers
- Any switch mode power circuit requiring a half bridge driver

## Related Literature

- [AN1896](#) "HIP2103, HIP2104 Evaluation Board User's Guide"
- [AN1899](#) "HIP2103, HIP2104 3-phase, Full or Half Bridge Motor Drive User's Guide"

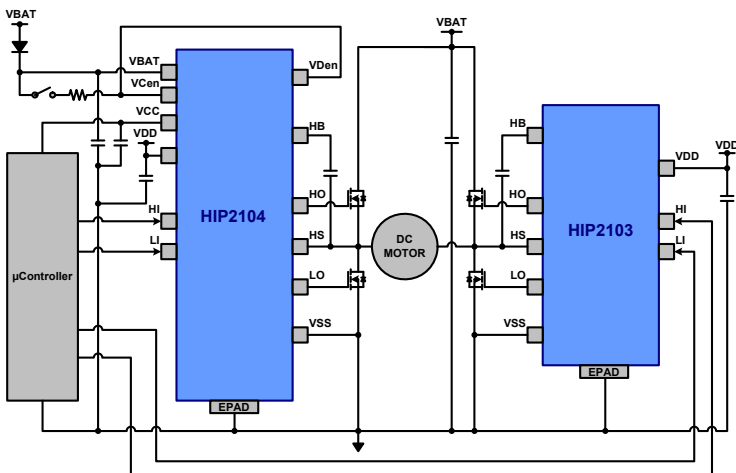

FIGURE 1. TYPICAL FULL BRIDGE APPLICATION

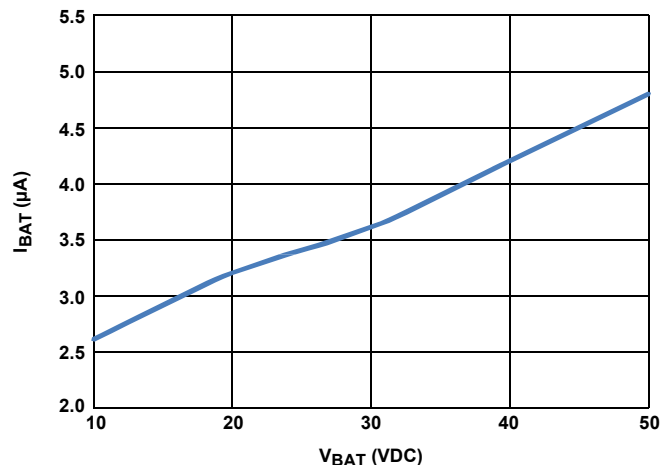
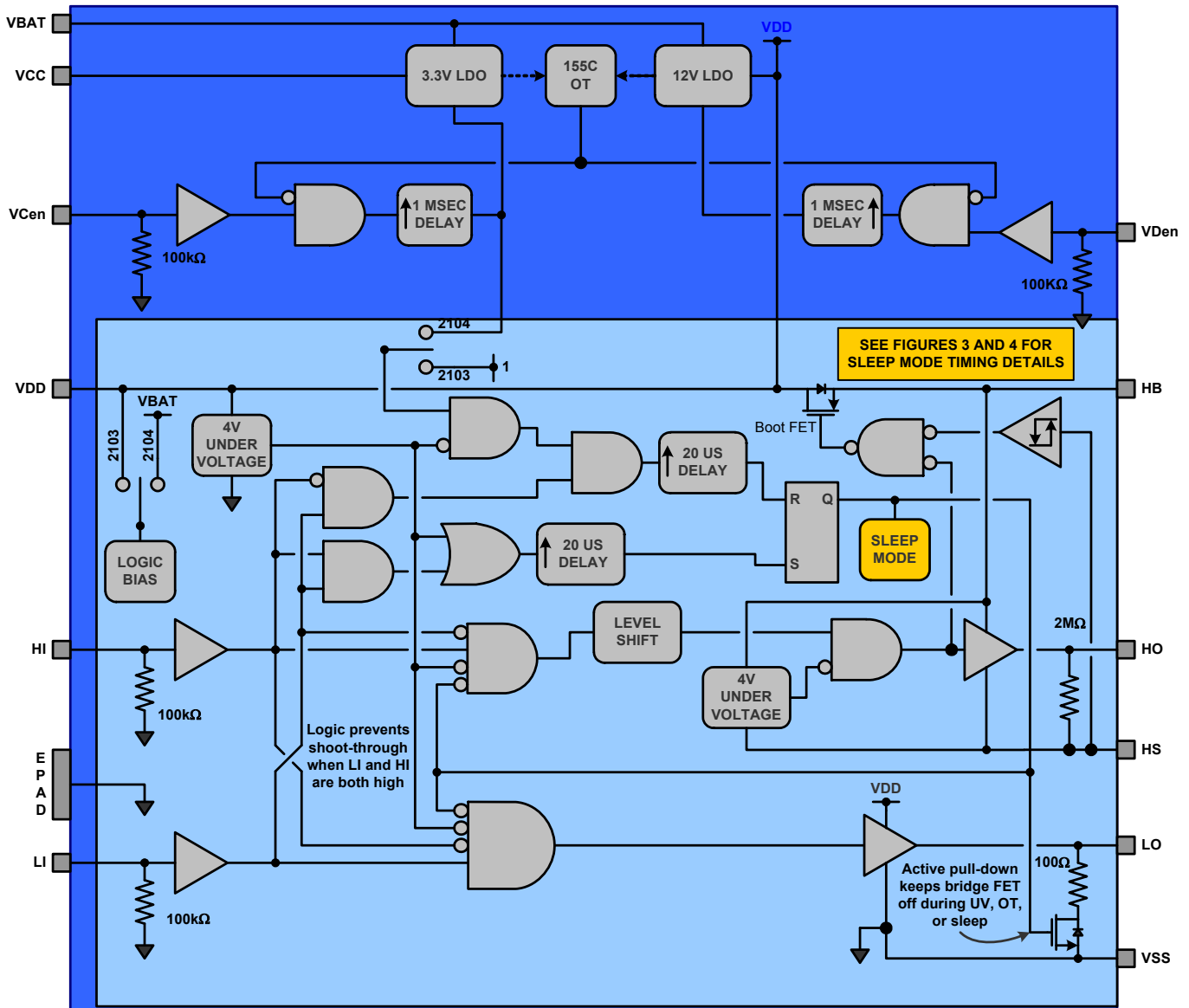

FIGURE 2. HIP2104 SHUTDOWN CURRENT vs V<sub>BAT</sub>

# HIP2103, HIP2104

## Block Diagram



### Symbol Glossary



Time delay functional block with rising edge prop delay (as indicated by the rising arrow on the input) and minimal falling edge delay.



Optional connections as indicated by part numbers

**HIP2103**

**HIP2104**

# HIP2103, HIP2104

## Pin Configurations

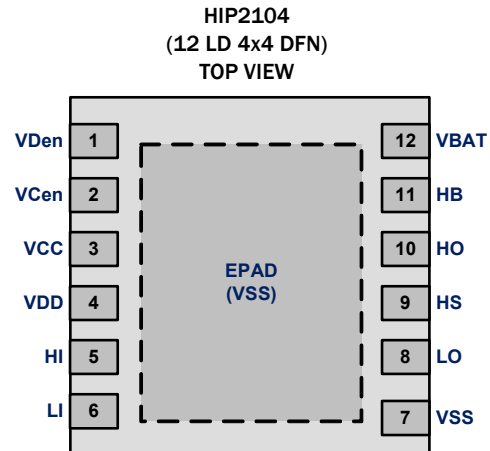
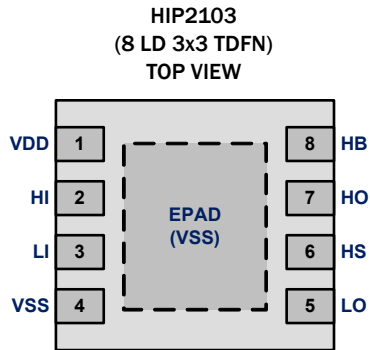

## Pin Descriptions

HIP2103	HIP2104	SYMBOL	DESCRIPTION
8 LD TDFN	12 LD DFN		
-	1	VDen	(HIP2104 only) VDD enable input, 3.3V or 5V logic compatible, $V_{BAT}$ tolerant. VDD output is turned on after 1ms debouncing period.
-	2	VCen	(HIP2104 only) VCC enable input, 3.3V or 5V logic compatible. $V_{BAT}$ tolerant. VCC output is turned on after 1ms debouncing period.
-	3	VCC	(HIP2104 only) 3.3V output voltage of linear regulator, 75mA. Enabled by VCen.
1	4	VDD	(HIP2103) Input voltage 14V max. (HIP2104) Output voltage of linear regulator, 12V nominal, 75mA. Enabled by VDen.
2	5	HI	High side input, 3.3V or 5V logic compatible. (HI -> HO).
3	6	LI	Low side Input, 3.3V or 5V logic compatible. (LI -> LO).
4	7	VSS	Signal ground.
5	8	LO	Low side driver Output. (LI -> LO).
6	9	HS	High side FET Source connection (low side boot capacitor connection).
7	10	HO	High side driver Output. (HI -> HO)
8	11	HB	High side Boot capacitor.
-	12	VBAT	(HIP2104 only) Positive battery (bridge voltage) connection.
EP	EP	EPAD	Exposed Pad, must be connected to signal ground.

# HIP2103, HIP2104

## Ordering Information

PART NUMBER (Notes 1, 2, 3, 4)	PART MARKING	UVLO (V)	VCC REGULATOR (V)	VDD REGULATOR (V)	PACKAGE (Pb-Free)	PKG. DWG. #
HIP2103FRTAZ	DZBF	4.0	N/A	N/A	8 Ld 3x3 TDFN	L8.3x3A
HIP2104FRAANZ	2104AN	4.0	3.3	12	12 Ld 4x4 DFN	L12.4x4A
HIP2103-4DEMO1Z	HIP2103, HIP2104 3-phase, Full, or Half Bridge Motor Drive Demonstration Board					
HIP2103_4MBEVAL1Z	HIP2103, HIP2104 Evaluation Board					

### NOTES:

1. Add "-T\*", suffix for tape and reel. Please refer to [TB347](#) for details on reel specifications.
2. These Intersil Pb-free plastic packaged products employ special Pb-free material sets, molding compounds/die attach materials, and 100% matte tin plate plus anneal (e3 termination finish, which is RoHS compliant and compatible with both SnPb and Pb-free soldering operations). Intersil Pb-free products are MSL classified at Pb-free peak reflow temperatures that meet or exceed the Pb-free requirements of IPC/JEDEC J STD-020.
3. For Moisture Sensitivity Level (MSL), please see device information page for [HIP2103](#), [HIP2104](#). For more information on MSL, please see Technical Brief [TB363](#).
4. All part numbers are rated -40°C to +125°C for the recommended operating junction temperature range.

# HIP2103, HIP2104

## Absolute Maximum Ratings (Note 5)

Supply Voltage $V_{DD}$ (HIP2103 only)	-0.3V to 16V
Bridge Supply Voltage $V_{BAT}$ (HIP2104 Only)	-0.3V to 60V
High side Bias Voltage ( $V_{HB} - V_{HS}$ ) (Note 10)	-0.3V to 16V
Logic Inputs V <sub>Cen</sub> , V <sub>Den</sub> (HIP2104 Only)	-0.3V to $V_{BAT} + 0.3V$
Logic Inputs LI, HI	-0.3V to $V_{DD} + 0.3V$
Output Voltage LO	-0.3V to $V_{DD} + 0.3V$
Output Voltage HO	$V_{HS} - 0.3V$ to $V_{HB} + 0.3V$
Voltage on HS (Note 9, 10)	-10V to 60V
Voltage on HB	$V_{HS} - 0.3V$ to 66V
Average Current in Boot Diode (Note 6)	100mA
Maximum Boot Cap Value	10 $\mu$ F
Average Output Current in HO and LO (Note 6)	200mA
ESD Ratings	
Human Body Model Class 2 (Tested per JESD22-A114E)	2000V
Charged Device Model Class IV	1000V
Latch-Up (Tested per JESD-78B; Class 2, Level A) all pins	100mA

## Thermal Information

Thermal Resistance (Typical)	$\theta_{JA}$ ( $^{\circ}C/W$ )	$\theta_{JC}$ ( $^{\circ}C/W$ )
8 Ld DFN Package (Notes 7, 8)	46	7
12 Ld TDFN Package (Notes 7, 8)	44	7
Max Power Dissipation at +25 $^{\circ}C$ in free air		
8 Ld DFN Package	2.3W	
12 Ld TDFN Package	2.2W	
Max Power Dissipation at +25 $^{\circ}C$ on copper plane		
8 Ld DFN Package	14.3W	
12 Ld TDFN Package	14.3W	
Storage Temperature Range	-65 $^{\circ}C$ to +150 $^{\circ}C$	
Maximum Operating Junction Temperature Range	-40 $^{\circ}C$ to +150 $^{\circ}C$	
Nominal Over Temperature Shut-down	+155 $^{\circ}C$	
Over Temperature Shut-down Range	+145 $^{\circ}C$ to +165 $^{\circ}C$	
Pb-Free Reflow Profile	see <a href="#">TB493</a>	

## Recommended Operating Conditions (Note 5)

Junction Temperature	-40 $^{\circ}C$ to +125 $^{\circ}C$
Supply Voltage, $V_{BAT}$ (HIP2104 only) (Note 11)	5.0V to 50V
Supply Voltage, $V_{DD}$	4.5V to 14V
High Side Bias Voltage ( $V_{HB} - V_{HS}$ ) (Note 10)	-0.3V to 14V
Voltage on HS, Continuous, $V_{HS}$ (Notes 9, 10)	-10V to 50V
Voltage on HB	$V_{HS} - 0.3V$ to 60V
Logic Inputs V <sub>Cen</sub> , V <sub>Den</sub> (HIP2104 only)	0V to $V_{BAT}$
Output Voltage (LO)	GND to $V_{DD}$
Output Voltage (HO)	$V_{HS}$ to $V_{HB}$
Average Output Current in HO and LO (Note 6)	0 to 150mA

**CAUTION:** Do not operate at or near the maximum ratings listed for extended periods of time. Exposure to such conditions may adversely impact product reliability and result in failures not covered by warranty.

### NOTES:

- All voltages are referenced to VSS unless otherwise specified.
- The average output current, when driving a power MOSFET or similar capacitive load, is the average of the **rectified** output current. The peak output currents of this driver are self limiting by trans conductance or  $r_{DS(ON)}$  and do not required any external components to minimize the peaks. If the output is driving a non-capacitive load, such as an LED, the maximum output current must be limited by external means to less than the specified recommended rectified average output current.
- $\theta_{JA}$  is measured in free air with the component mounted on a high effective thermal conductivity test board with "direct attach" features. See Tech Brief TB379.
- For  $\theta_{JC}$ , the "case temp" location is the center of the exposed metal pad on the package underside.
- The maximum value of  $V_{HS}$  must be limited so that  $V_{HB}$  does not exceed 60V.
- The -10V limit for  $V_{HS}$  has no time duration restrictions as far as the HS pin is concerned however, be aware that if the duration of the negative voltage is significant with respect to the time constant to charge the boot capacitor (across HB and HS) the voltage on the boot capacitor can charge as high as  $V_{DD} - (-V_{HS}) = (V_{DD} + V_{HS})$  potentially violating the Voltage Rating for ( $V_{HB} - V_{HS}$ ).
- When  $V_{BAT} < \sim 13V$ , the output of VDD will sag. The 5V minimum specified for  $V_{BAT}$  is the minimum level for which the UVLO will not activate.

**DC Electrical Specifications**  $V_{DD} = V_{HB} = 12V$  (for HIP2103),  $V_{SS} = V_{HS} = 0V$ ,  $V_{BAT} = 18V$  (for HIP2104), LI = HI = 0V. No load on HO and LO unless otherwise specified. **Boldface limits apply over the operating junction temperature range, -40 $^{\circ}C$  to +125 $^{\circ}C$ .**

PARAMETERS	SYMBOL	TEST CONDITIONS	$T_J = +25^{\circ}C$			$T_J = -40^{\circ}C$ to +125 $^{\circ}C$		UNITS
			MIN	TYP	MAX	MIN (Note 12)	MAX (Note 12)	
<b>LINEAR BIAS SUPPLIES (HIP2104 only)</b>								
$V_{DD}$ Output Voltage Over Rated Line, Load, and Temperature	$V_{DD12}$	Nominal $V_{DD} = 12V$	-2.5	+2.1	+4.8	<b>-5%</b>	<b>+5%</b>	%
$V_{DD}$ Rated Output Current	$I_{DDR}$		75					mA
$V_{DD}$ Output Current Limit (brick wall)	$I_{DD12}$		83	151	237	<b>80</b>	<b>245</b>	mA
$V_{DD}$ Drop Output Voltage (Figure 7)	VDdout	Load = 75mA				<b>0.06</b>	<b>0.7</b>	V

# HIP2103, HIP2104

**DC Electrical Specifications**  $V_{DD} = V_{HB} = 12V$  (for HIP2103),  $V_{SS} = V_{HS} = 0V$ ,  $V_{BAT} = 18V$  (for HIP2104),  $LI = HI = 0V$ . No load on HO and LO unless otherwise specified. **Boldface limits apply over the operating junction temperature range, -40°C to +125°C. (Continued)**

PARAMETERS	SYMBOL	TEST CONDITIONS	$T_J = +25^\circ C$			$T_J = -40^\circ C$ to $+125^\circ C$		UNITS
			MIN	TYP	MAX	MIN (Note 12)	MAX (Note 12)	
$V_{CC}$ Output Voltage Over Rated Line, Load, and Temperature	$V_{CC3.3}$	Nominal $V_{CC} = 3.3V$	-3.9	+1.8	+4.3	<b>- 5%</b>	<b>+ 5%</b>	%
$V_{CC}$ Rated Output Current	$I_{CDR}$		75					mA
$V_{CC}$ Output Current Limit (brick wall)	$I_{CC}$		83	149	237	<b>80</b>	<b>245</b>	mA
$V_{CC}$ Drop Output Voltage (Figure 8)	$V_{Cdout}$	Load = 75mA				<b>0.5</b>	<b>0.9</b>	V
<b>BIAS CURRENTS</b>								
$V_{DD}$ Sleep Mode Current (HIP2103)	$I_{DDs}$	$HI = LI = 1$ , after 10 to 30 $\mu s$ delay		9.4			<b>20</b>	$\mu A$
$V_{BAT}$ Shutdown Current (HIP2104)	$I_{DDsbatt}$	$V_{Cen} = V_{Den} = 0$ , after 10 to 30 $\mu s$ delay, $V_{BAT} = 50V$		4.8			<b>15</b>	$\mu A$
$V_{BAT}$ (HIP2104) or $V_{DD}$ (HIP2103) Operating Current	$I_{DD020}$	$f = 20kHz$ , $HI = \bar{LI} = 50\%$ square wave $V_{DD} = 12V$ for HIP2103		832			<b>1040</b>	$\mu A$
	$I_{DD010}$	$f = 10kHz$ , $HI = \bar{LI} = 50\%$ square wave $V_{DD} = 12V$ for HIP2103		661			<b>825</b>	$\mu A$
HB to HS Quiescent Current	$I_{HBQ}$	$HI = 1$ , $LO = 0$ , $V_{HS} = 0V$ , $V_{HB} = 12V$		135			<b>160</b>	$\mu A$
HB to HS Operating Current	$I_{HBS20K}$	$LI = 0$ , $HI = 50\%$ square wave 20kHz, $V_{HS} = 0V$ , $V_{HB} = 12V$		206			<b>245</b>	$\mu A$
	$I_{HBS10K}$	$LI = 0$ , $HI = 50\%$ square wave 10kHz, $V_{HS} = 0V$ , $V_{HB} = 12V$		167			<b>193</b>	$\mu A$
HB to $V_{SS}$ Operating Current	$I_{HB20K}$	$LI = 0$ , $HI = 50\%$ square wave 20kHz, $V_{HB} = 60V$ , $V_{HS} = 50V$		201			<b>240</b>	$\mu A$
	$I_{HB10K}$	$LI = 0$ , $HI = 50\%$ square wave 10kHz, $V_{HB} = 60V$ , $V_{HS} = 50V$		164			<b>190</b>	$\mu A$
HB to $V_{SS}$ Quiescent Current	$I_{HBQ}$	$LI = HI = 0V$ ; $V_{HB} = 60V$ , $V_{HS} = 50V$		120			<b>145</b>	$\mu A$
HS to $V_{SS}$ Current, Sleep Mode	$I_{HBS}$	$LI = HI = 1$ ; HB open, $V_{HS} = 50V$		0.03			<b>+1</b>	$\mu A$
<b>INPUT PINS</b>								
Low Level Input Voltage Threshold	$V_{IL}$	$V_{DD} = 12V$		1.44		<b>1.18</b>	<b>1.63</b>	V
High Level Input Voltage Threshold	$V_{IH}$			2.06		<b>1.73</b>	<b>2.4</b>	V
Input Voltage Hysteresis	$V_{Hys}$			0.62		<b>0.48</b>	<b>0.85</b>	V
Low Level Input Voltage Threshold	$V_{IL}$	$V_{DD} = 5V$		1.13		<b>0.9</b>	<b>1.25</b>	V
High Level Input Voltage Threshold	$V_{IH}$			1.63		<b>1.38</b>	<b>1.84</b>	V
Input Voltage Hysteresis	$V_{Hys}$			0.50		<b>0.36</b>	<b>0.63</b>	V
Input Pull-Down	$R_I$			100		<b>80</b>	<b>130</b>	k $\Omega$
<b>UNDERVOLTAGE LOCKOUT (Note 13)</b>								
$V_{DD}$ Falling Threshold	$V_{UVF4}$	4V option		4.2		<b>3.98</b>	<b>4.36</b>	V
$V_{DD}$ Threshold Hysteresis	$V_{UVH}$			0.34		<b>0.267</b>	<b>0.37</b>	V
<b>BOOT FET</b>								

# HIP2103, HIP2104

**DC Electrical Specifications**  $V_{DD} = V_{HB} = 12V$  (for HIP2103),  $V_{SS} = V_{HS} = 0V$ ,  $V_{BAT} = 18V$  (for HIP2104),  $LI = HI = 0V$ . No load on HO and LO unless otherwise specified. **Boldface limits apply over the operating junction temperature range, -40°C to +125°C. (Continued)**

PARAMETERS	SYMBOL	TEST CONDITIONS	$T_J = +25^\circ\text{C}$			$T_J = -40^\circ\text{C to } +125^\circ\text{C}$		UNITS
			MIN	TYP	MAX	MIN (Note 12)	MAX (Note 12)	
On Resistance	$R_{Don}$	$I_{VDD-HB} = 75\text{mA}$ , $HI = 0$ , $LI = 1$		8.2		<b>2.42</b>	<b>15</b>	$\Omega$
<b>LO GATE DRIVER</b>								
Sinking $r_{DS(ON)}$	$R_{DSL0L}$	$I_{LO} = 100\text{mA}$ , $LI = 0$		2.68		<b>0.61</b>	<b>11</b>	$\Omega$
Sourcing $r_{DS(ON)}$	$R_{DSL0H}$	$I_{LO} = -75\text{mA}$ , $HI = 1$		6.47		<b>2.3</b>	<b>15</b>	$\Omega$
Peak Pull-Up Current	$I_{LOH12}$	$HI = 1$ $V_{DD} = 12V$ , $C_{load} = 1000\text{pF}$		1				A
	$I_{LOH5}$	$HI = 1$ $V_{DD} = 5V$ , $C_{load} = 1000\text{pF}$ (HIP2103 only)						A
Peak Pull-Down Current	$I_{LOL12}$	$HI = 0$ $V_{DD} = 12V$ , $C_{load} = 1000\text{pF}$		2				A
	$I_{LOL5}$	$HI = 0$ $V_{DD} = 5V$ , $C_{load} = 1000\text{pF}$ (HIP2103 only)						A
<b>HO GATE DRIVER</b>								
Sinking $r_{DS(ON)}$	$R_{DSH0L}$	$I_{HO} = 100\text{mA}$ , $HI = 0$		6.1		<b>4.4</b>	<b>11</b>	$\Omega$
Sourcing $r_{DS(ON)}$	$R_{DSH0H}$	$I_{HO} = -100\text{mA}$ , $HI = 1$		11.9		<b>9.7</b>	<b>15</b>	$\Omega$
Peak Pull-Up Current	$I_{HOH12}$	$HI = 1$ $V_{DD} = 12V$ , $C_{load} = 1000\text{pF}$		1				A
	$I_{HOH5}$	$HI = 1$ $V_{DD} = 5V$ , $C_{load} = 1000\text{pF}$ (HIP2103 only)		1				A
Peak Pull-Down Current	$I_{HOL12}$	$HI = 0$ $V_{DD} = 12V$ , $C_{load} = 1000\text{pF}$		2				A
	$I_{HOL5}$	$HI = 0$ $V_{DD} = 5V$ , $C_{load} = 1000\text{pF}$ (HIP2103 only)						A

**NOTES:**

- Parameters with MIN and/or MAX limits are 100% tested at +25°C, unless otherwise specified. Temperature limits established by characterization and are not production tested.
- The UV lockout does not disable the  $V_{DD}$  and  $V_{CC}$  outputs.

# HIP2103, HIP2104

**AC Electrical Specifications**  $V_{DD} = 12V$ ,  $GND = 0V$ , No Load on OUTA or OUTB, Unless Otherwise Specified.  $V_{DD}$  load =  $1\mu F$  and  $V_{CC}$  load =  $1\mu F$  (HIP2104 only) **Boldface limits apply over the operating junction temperature range,  $-40^{\circ}C$  to  $+125^{\circ}C$ .**

PARAMETERS	SYMBOL	TEST CONDITIONS	$T_J = +25^{\circ}C$			$T_J = -40^{\circ}C$ to $+125^{\circ}C$		UNITS
			MIN	TYP	MAX	MIN	MAX	
VDen and VCen Turn-On Delay (Figure 5) (HIP2104 only)	$t_{Den}$ $t_{Cen}$	$V_{Den} = V_{Cen} = 1$ , $V_{CC} = V_{DD} = 10\%$ , $V_{BAT} = 50V$		1.69		<b>1.0</b>	<b>2.5</b>	ms
VDen and VCen Turn-on Delay (Figure 5) (HIP2104 only)	$t_{Den}$ $t_{Cen}$	$V_{Den} = V_{Cen} = 1$ , $V_{CC} = V_{DD} = 10\%$ , $V_{BAT} = 18V$		1.68		<b>1.1</b>	<b>2.54</b>	ms
VDen and VCen Turn-on Delay Matching (Figure 5) ( $V_{Den} - V_{Cen}$ ) (HIP2104 only)	$t_{VenM}$	$V_{Den} = V_{Cen} = 1$ , $V_{CC} = 10\%$ , $V_{DD} = 10\%$ $V_{BAT} = 50V$		40		<b>-290</b>	<b>340</b>	ns
VDen and VCen Turn-on Delay Matching (Figure 5) ( $V_{Den} - V_{Cen}$ ) (HIP2104 only)	$t_{VenM}$	$V_{Den} = V_{Cen} = 1$ , $V_{CC} = 10\%$ , $V_{DD} = 10\%$ $V_{BAT} = 18V$		40		<b>-290</b>	<b>350</b>	ns
LO Turn-Off Propagation Delay (LI to LO falling) (Figure 6)	$t_{FL12}$	$HI = 0$ , $LI = 1$ to $0$ $V_{DD} = 12V$		27		<b>13</b>	<b>39</b>	ns
	$t_{FL5}$	$HI = 0$ , $LI = 1$ to $0$ $V_{DD} = 5V$ (HIP2103 only)		30		<b>23</b>	<b>46</b>	ns
HO Turn-Off Propagation Delay (HI to HO falling) (Figure 6)	$t_{FH12}$	$LI = 0$ , $HI = 1$ to $0$ $V_{DD} = 12V$		23		<b>10</b>	<b>35</b>	ns
	$t_{FH5}$	$LI = 0$ , $HI = 1$ to $0$ $V_v = 5V$ (HIP2103 only)		27		<b>19</b>	<b>38</b>	ns
LO Turn-On Propagation Delay (LI to LO rising) (Figure 6)	$t_{RL12}$	$HI = 0$ , $LI = 0$ to $1$ $V_{DD} = 12V$		21		<b>7</b>	<b>32</b>	ns
	$t_{RL5}$	$HI = 0$ , $LI = 0$ to $1$ $V_{DD} = 5V$ (HIP2103 only)		25		<b>12</b>	<b>37</b>	ns
HO Turn-On Propagation Delay (HI to HO rising) (Figure 6)	$t_{RH12}$	$LI = 0$ , $HI = 0$ to $1$ $V_{DD} = 12V$		23		<b>9</b>	<b>35</b>	ns
	$t_{RH5}$	$LI = 0$ , $HI = 0$ to $1$ $V_{DD} = 5V$ (HIP2103 only)		28		<b>15</b>	<b>40</b>	ns
Turn-On/Off Propagation Mismatch (HO rising to LO falling) (Figure 6)	$t_{MONHL}$	$LI = 1 \rightarrow 0$ $HI = 0 \rightarrow 1$		-2.5		<b>-8</b>	<b>+3</b>	ns
Turn-On/Off Propagation Mismatch (LO rising to HO falling) (Figure 6)	$t_{MONLH}$	$HI = 1 \rightarrow 0$ $LI = 0 \rightarrow 1$		-4.2		<b>-9.0</b>	<b>+5.4</b>	ns
LO Output Rise Time (10% to 90%)	$t_{R12}$	$CL = 1nF$ $V_{DD} = 12V$		20.5		<b>7</b>	<b>35</b>	ns
	$t_{R5}$	$CL = 1nF$ $V_{DD} = 5V$ (HIP2103 only)		19.5		<b>6</b>	<b>32</b>	ns
HO Output Rise Time (10% to 90%)	$t_{R12}$	$CL = 1nF$ $V_{DD} = 12V$		21		<b>8</b>	<b>35</b>	ns
	$t_{R5}$	$CL = 1nF$ $V_{DD} = 5V$ (HIP2103 only)		21		<b>8</b>	<b>34</b>	ns
LO Output Fall Time (90% to 10%)	$t_{F12}$	$CL = 1nF$ $V_{DD} = 12V$		17		<b>3</b>	<b>30</b>	ns
	$t_{F5}$	$CL = 1nF$ $V_{DD} = 5V$ (HIP2103 only)		17		<b>3</b>	<b>30</b>	ns
HO Output Fall Time (90% to 10%)	$t_{F12}$	$CL = 1nF$ $V_{DD} = 12V$		16		<b>2</b>	<b>30</b>	ns
	$t_{F5}$	$CL = 1nF$ $V_{DD} = 5V$ (HIP2103 only)		16		<b>1.5</b>	<b>29</b>	ns

# HIP2103, HIP2104

**AC Electrical Specifications**  $V_{DD} = 12V$ ,  $GND = 0V$ , No Load on OUTA or OUTB, Unless Otherwise Specified.  $V_{DD}$  load =  $1\mu F$  and  $V_{CC}$  load =  $1\mu F$  (HIP2104 only) **Boldface limits apply over the operating junction temperature range,  $-40^{\circ}C$  to  $+125^{\circ}C$ . (Continued)**

PARAMETERS	SYMBOL	TEST CONDITIONS	$T_J = +25^{\circ}C$			$T_J = -40^{\circ}C$ to $+125^{\circ}C$		UNITS
			MIN	TYP	MAX	MIN	MAX	
Time Delay to Set Sleep Mode (Note 14, Figure 4)	$t_{SlpS}$	HI = LI = 0 -> 1		17		<b>9</b>	<b>27</b>	$\mu s$
Time Delay to Reset Sleep Mode (Note 14, Figure 4)	$t_{SlpR}$	HI = 0, LI = 0 -> 1		17		<b>9</b>	<b>27</b>	$\mu s$

NOTE:

14. When HI and LI are on simultaneously, HO and LO are never on simultaneously. This feature is intended to initiate sleep. This feature cannot be used to prevent shoot-through for normal alternating switching between LI and HI. Dead time must be provided when HI = 0 -> LI = 1, or LI = 0 -> HI = 1. See Timing Diagrams (Figure 4).

## Timing Diagrams

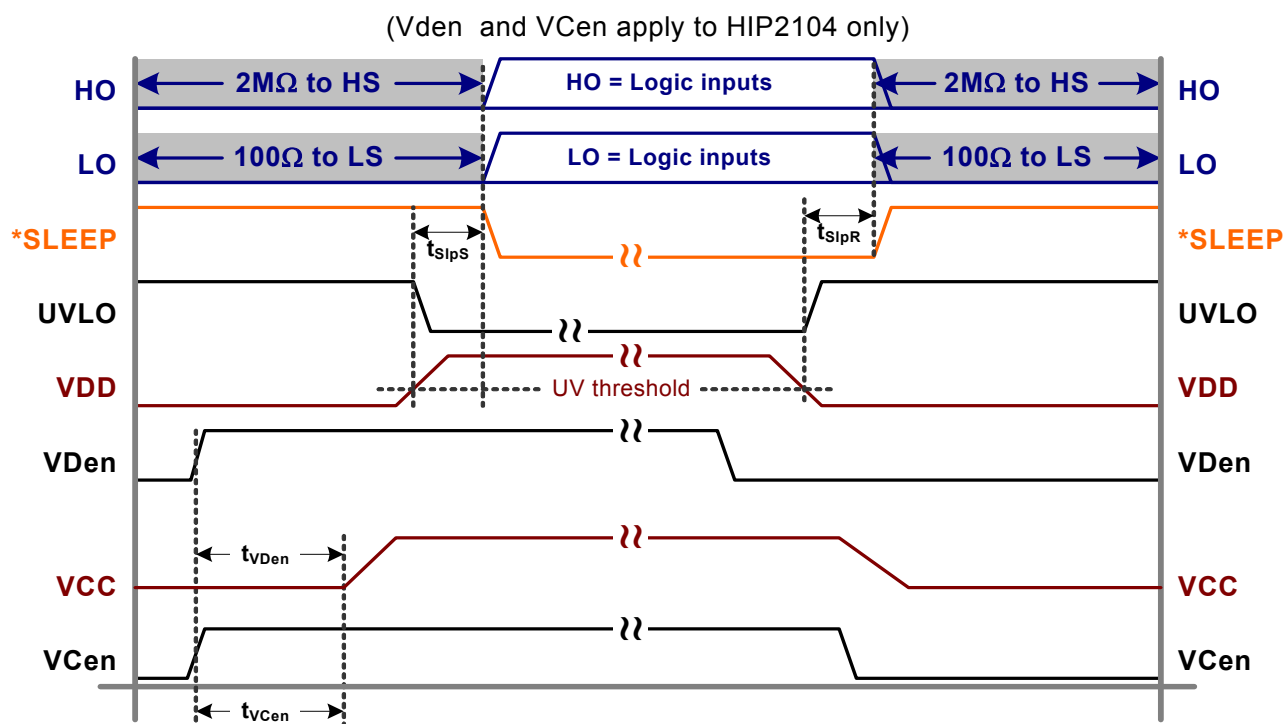

**\*Sleep is an internal state. Minimal  $I_{DD}$  or  $I_{BAT}$  current results when active (high).**

FIGURE 3. VDD POWER-ON/OFF TIMING FOR SLEEP MODE

## Timing Diagrams (Continued)

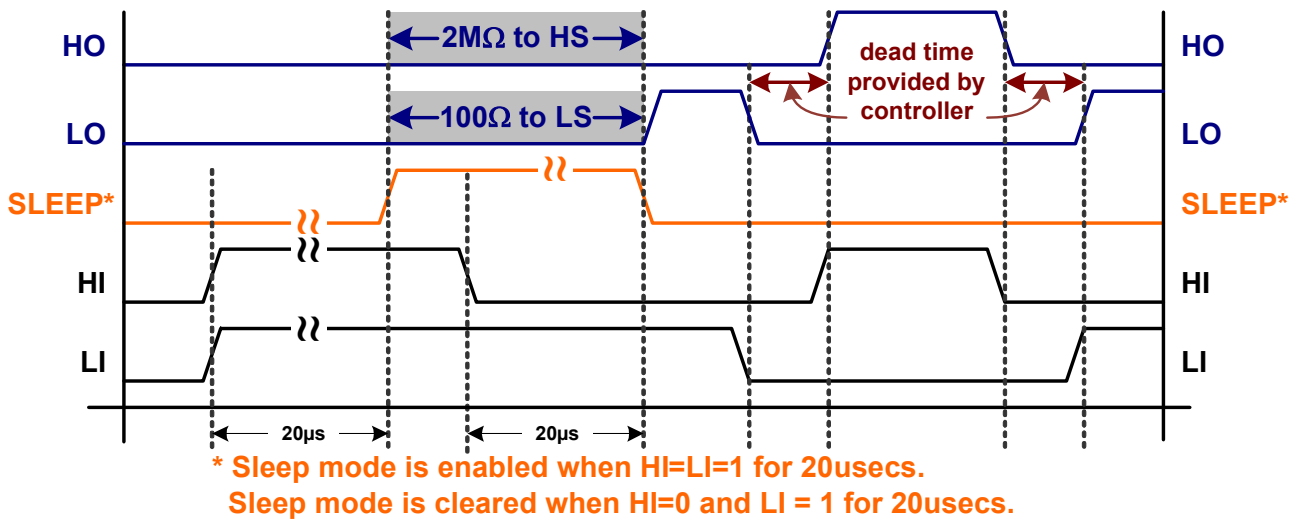

FIGURE 4. SLEEP MODE ENABLED OR CLEARED BY HI AND LI INPUTS

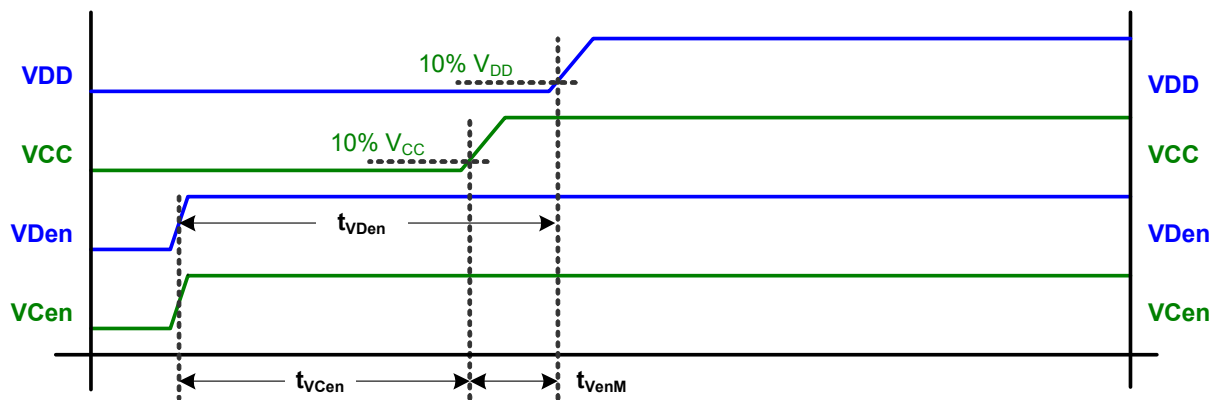

FIGURE 5. VCEN AND VDEN DELAY MATCHING

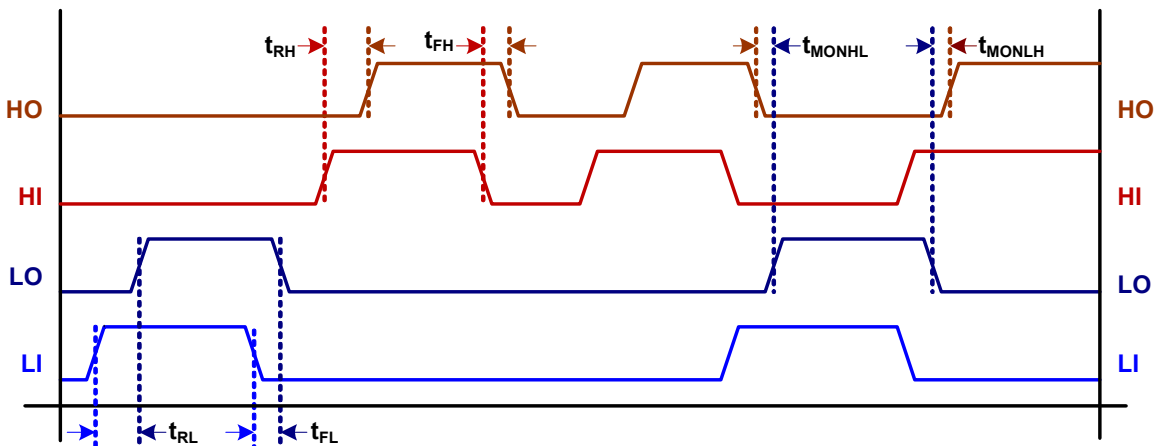

FIGURE 6. PROPAGATION DELAYS

## Typical Performance Curves

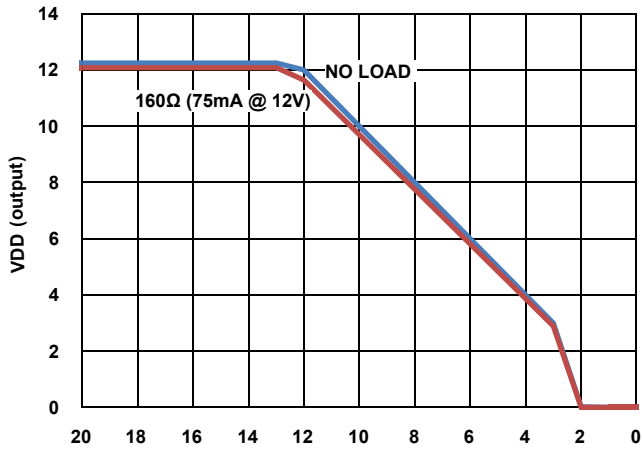

FIGURE 7.  $V_{DD}$  DROPOUT vs  $V_{BAT}$  (HIP2104 ONLY)

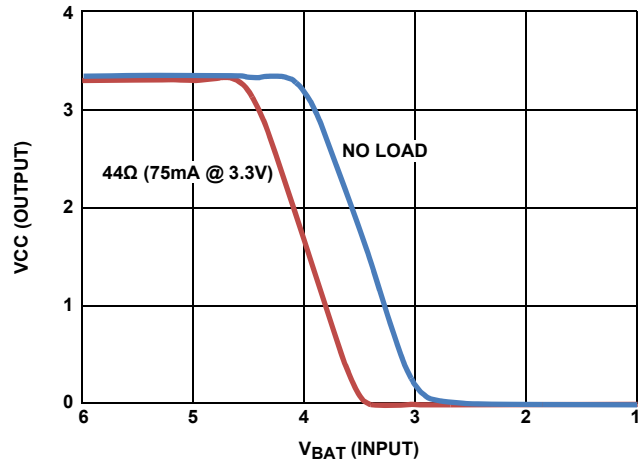

FIGURE 8.  $V_{CC}$  DROPOUT vs  $V_{BAT}$  (HIP2104 ONLY)

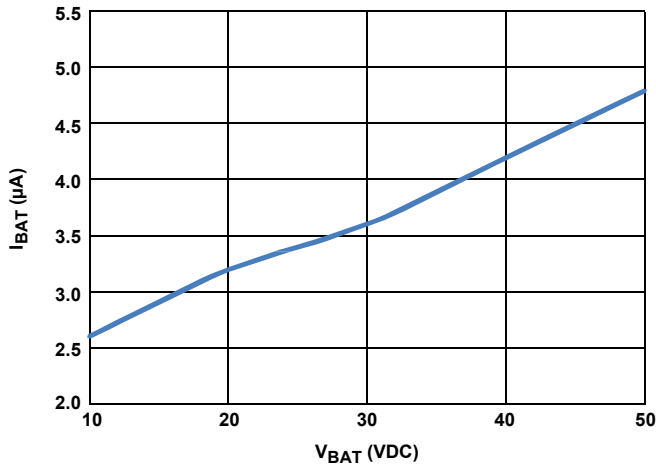

FIGURE 9. HIP2104 SHUTDOWN CURRENT  
( $V_{CEN} = V_{DEN} = 0$ ,  $H_S = V_{BAT}$ )

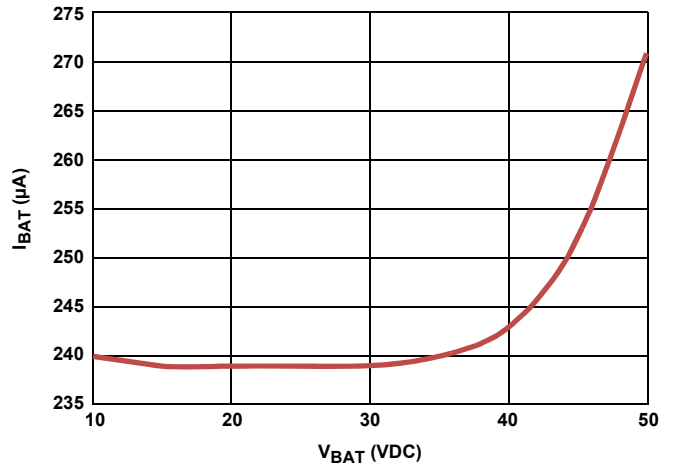

FIGURE 10. HIP2104 QUIESCENT  $I_{BAT}$  ( $V_{CEN} = V_{DEN} = LI = HI = 1$ )

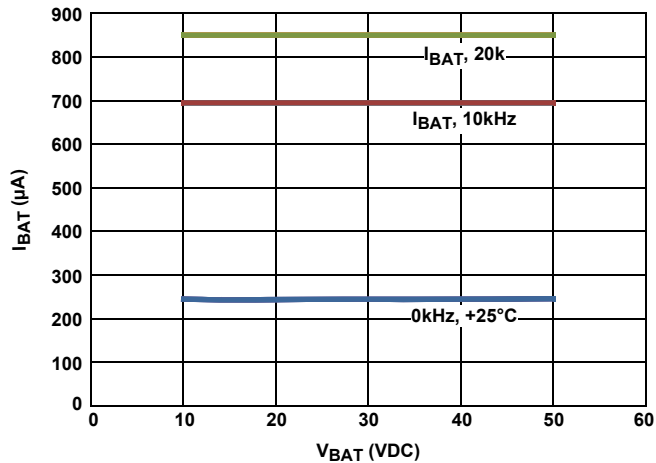

FIGURE 11. HIP2104  $V_{DD}$  OPERATING CURRENT LIMIT

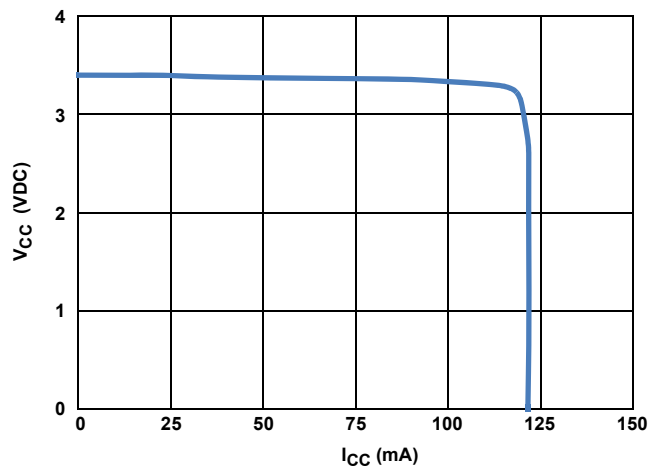

FIGURE 12. HIP2104  $V_{CC}$  CURRENT LIMIT

## Typical Performance Curves (Continued)

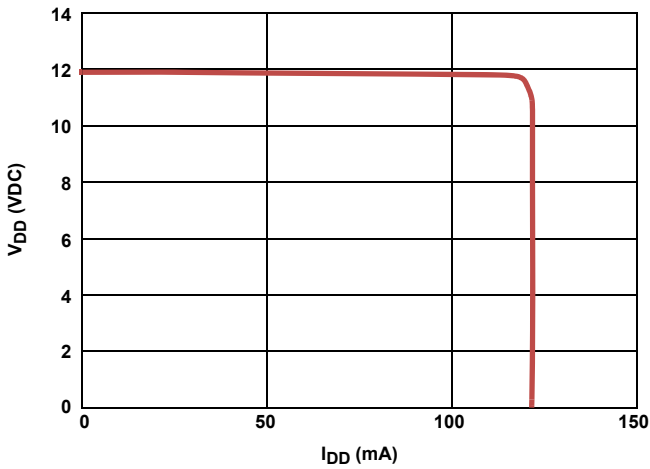

FIGURE 13. HIP2104 V<sub>DD</sub> CURRENT LIMIT, 0kHz

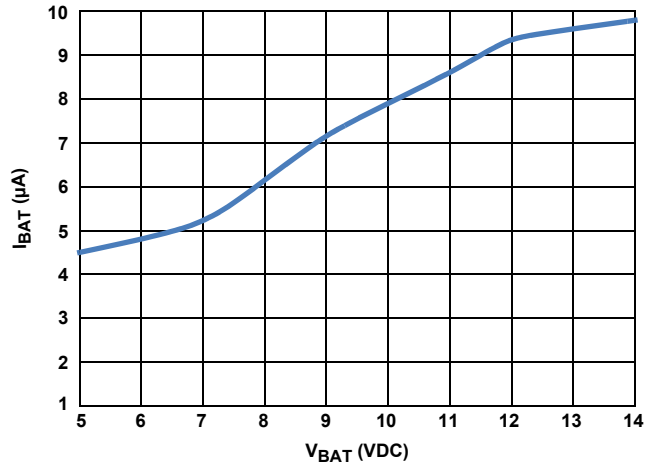

FIGURE 14. HIP2103 SLEEP CURRENT (HI = LI = 1)

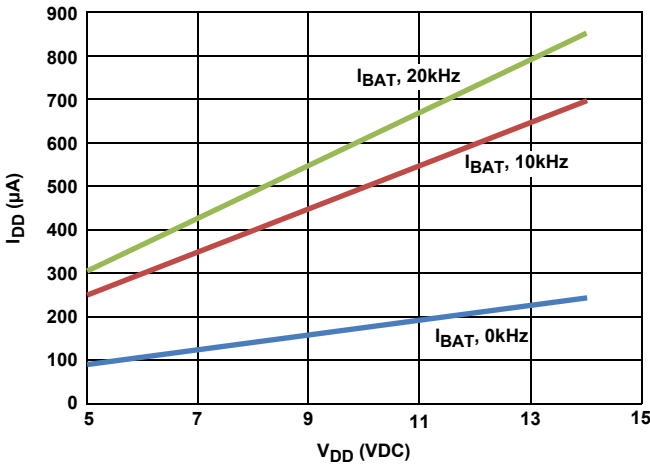

FIGURE 15. HIP2103 OPERATING CURRENT

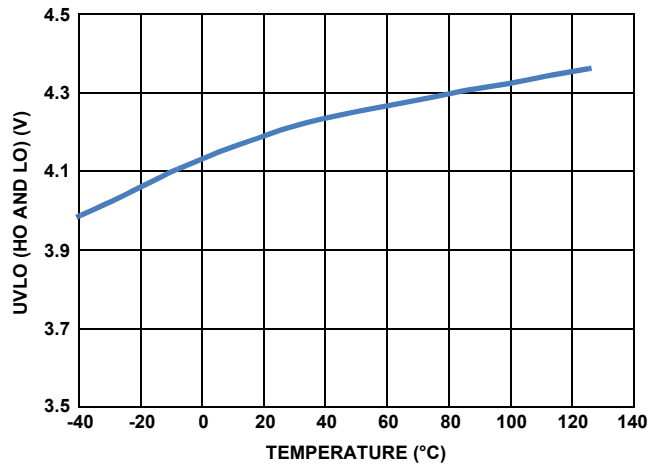

FIGURE 16. HIP2103, HIP2104 UNDERVOLTAGE LOCKOUT

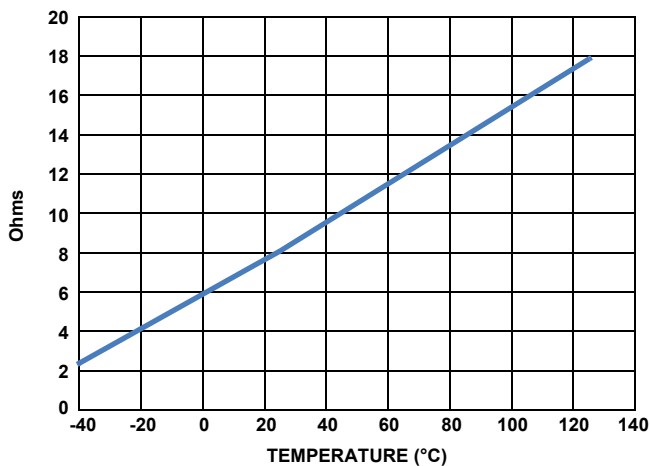

FIGURE 17. BOOT FET RESISTANCE

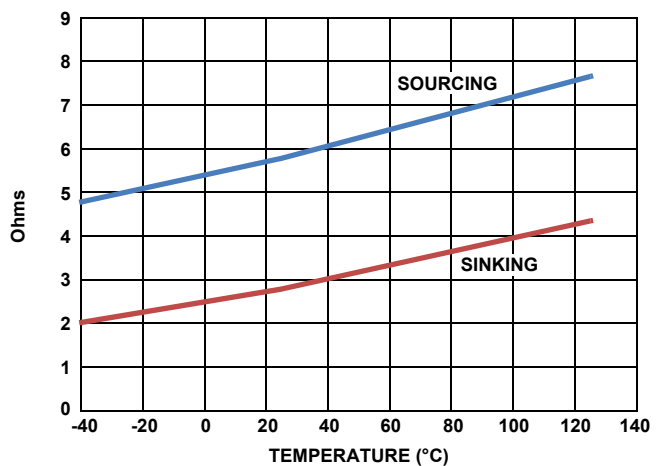

FIGURE 18. HO OUTPUT RESISTANCE

## Typical Performance Curves (Continued)

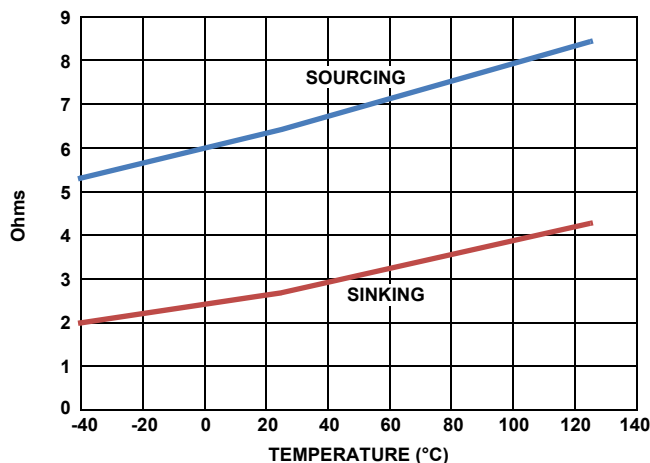

FIGURE 19. LO OUTPUT RESISTANCE

## Functional Description

The following functional description references the “Block Diagram” on page 2.

### Overview

The HIP2103 has independent control inputs, LI and HI, for each output, LO and HO. There is no logic inversion for these input/output pairs. To minimize the possibility of shoot-through failures of the bridge FETs caused by improper LI and HI signals from an external controller, internal logic in the driver prevents both outputs being high simultaneously. When either input is high, the high input must go low before a high on the other input propagates to its respective drive output. If both inputs are high simultaneously, both output are low. If one input is high, followed by the other input going high, the internal logic prevents any shoot through. Note that the internal logic does not prevent shoot-through if the dead-time provided by the external controller is not sufficiently long as required by the turn-on/off times of the bridge FETS.

If both inputs are high simultaneously for longer than 30µs, the driver initiates a Sleep Mode to reduce the bias current to minimize the battery drain. When in Sleep Mode, the HO output is in a high-impedance state (2MΩ between HO and HS) and the LO output is held low with an active 100Ω pull-down resistor. The 100Ω pull-down prevents inadvertent shoot-through resulting from transients on the bridge voltage while both drivers are in the Sleep Mode.

The undervoltage lockout (UVLO) on V<sub>DD</sub> drives HO and LO low when V<sub>DD</sub> is less than the UV threshold. Sleep Mode is initiated if UVLO is asserted for longer than 30µs.

The high-side driver bias is established by the boot capacitor connected between HB and HS. The charge on the boot capacitor is provided by the internal boot FET that is connected between V<sub>DD</sub> and HB. The current path to charge the boot cap is enabled (boot FET is on) when the drain voltage on the low-side bridge FET (V<sub>HO</sub>) is <1V and when HO = 0. When the boot FET is on, the boot cap is charged to approximately V<sub>DD</sub>.

The boot FET turns off when HO = 1. The boot capacitor provides the charge necessary to turn on the FET and maintains the bias voltage on the high side driver for the duration of the period while the FET is on. See the following for details on selecting the boot capacitor value.

The peak charge current is limited in amplitude by the inherent resistance of the boot FET and by the delta voltage between V<sub>DD</sub> and the drain-source voltage of the low-side bridge FET (V<sub>HS</sub>) less the boot cap voltage. Assuming that the on time of the low-side FET is sufficiently long to fully charge the boot capacitor, the boot voltage charges very close to V<sub>DD</sub> (less the voltage across the drain-source of the low-side bridge FET).

When the HI input transitions high, the high-side bridge FET is driven on. Because the HS node is connected to the source of the high-side FET, the HS node rises almost to the level of the bridge voltage, V<sub>BAT</sub> (less the conduction voltage across the bridge FET). Because the boot capacitor voltage is referenced to the source voltage of the high-side FET, the HB node is V<sub>DD</sub> volts above the HS node. Simultaneously with HI = 1, the boot FET is turned off preventing the boot capacitor from discharging back to V<sub>DD</sub>. Because the high-side driver circuit is referenced to the HS node, the HO output is now approximately V<sub>HB</sub> + V<sub>BAT</sub> above ground.

During the low to high transition of the phase node (HS), the boot capacitor sources the necessary gate charge to fully enhance the high-side bridge FET gate. After the gate of the bridge FET is fully charged, the boot capacitor no longer sources charge to the gate but continues to provide bias current to the high-side driver through out the period while the high-side bridge FET is on.

To prevent the voltage on the boot capacitor from drooping excessively, the boot capacitor value must be sized appropriately. If the boot voltage droops to the UVLO threshold, the high-side FET is turned off to prevent damage due to insufficient gate voltage.

# HIP2103, HIP2104

## Selecting the Boot Capacitor Value

The boot capacitor value is chosen not only to supply the internal bias current of the high-side driver but also, and more significantly, to provide the gate charge of the driven FET without causing the boot voltage to sag excessively. In practice, the boot capacitor should have a total charge that is about 20 times the gate charge of the driven power FET for approximately a 5% drop in voltage after charge has been transferred from the boot capacitor to the gate capacitance.

The following parameters are required to calculate the value of the boot capacitor for a specific amount of voltage droop when using the HIP2103, HIP2104. In the following example, some values used are specific to the HIP2103, HIP2104 and others are arbitrary. The values should be changed to comply with the actual application.

$V_{DD} = 12V$	This is the nominal value of VDD for the HIP2104
$V_{HB} = V_{DD} = V_{HO}$	High side driver bias voltage referenced to VHS
Period = 100 $\mu$ s	This is the longest expected switching period
$I_{HB} = I_{HBS20K} + I_{HB20K} = 295\mu A$	High side driver bias current at 20kHz
RGS = 10k $\Omega$	Gate-source resistor
Ripple = 5%	Desired ripple voltage on the boot cap
Igate_leak = 100nA	Gate leakage current (from vendor datasheet)
Qg40_12V = 45nC	From Figure 20

The following equations calculate the total charge required for the Period:

$$Q_c = Q_{g40\_12V} + \text{Period} \times (I_{HB} + V_{HO}/R_{GS} + I_{\text{gate\_leak}})$$

$$C_{\text{boot}} = Q_c / (\text{Ripple} \times V_{DD})$$

$$C_{\text{boot}} = 0.324\mu F$$

If the gate to source resistor is removed (RGS is usually not needed or recommended), then:

$$C_{\text{boot}} = 0.124\mu F$$

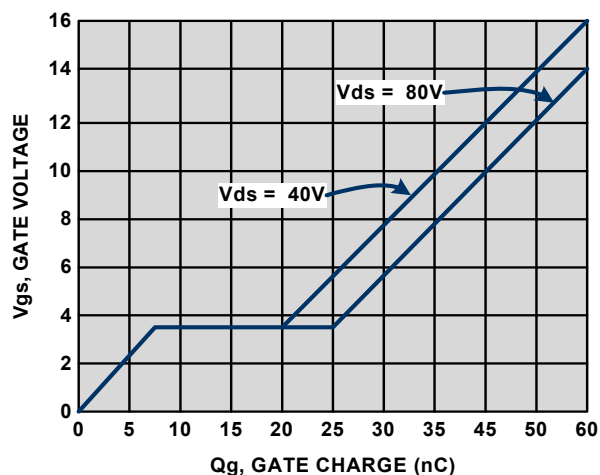

FIGURE 20. TYPICAL MOSFET GATE CHARGE vs GATE VOLTAGE

## Typical Applications

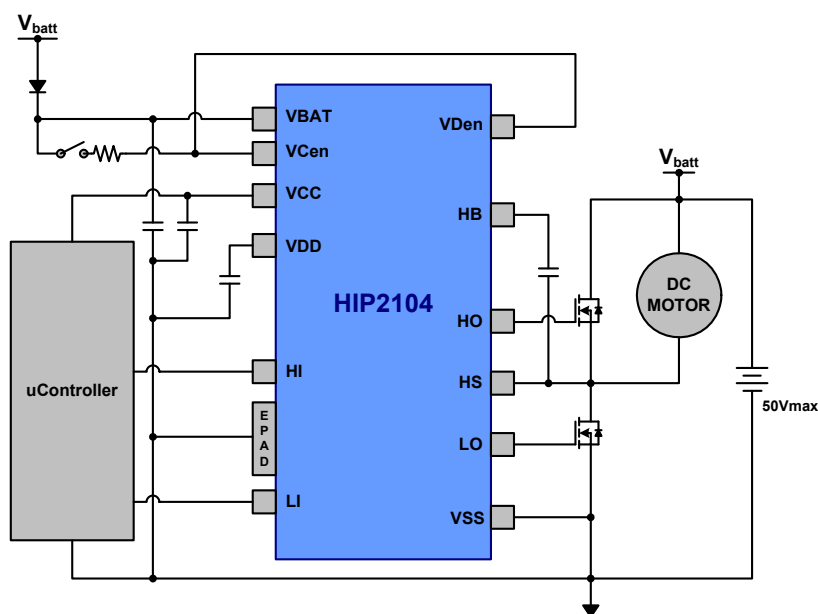

FIGURE 21. HALF BRIDGE MOTOR DRIVE TOPOLOGY

## Typical Applications

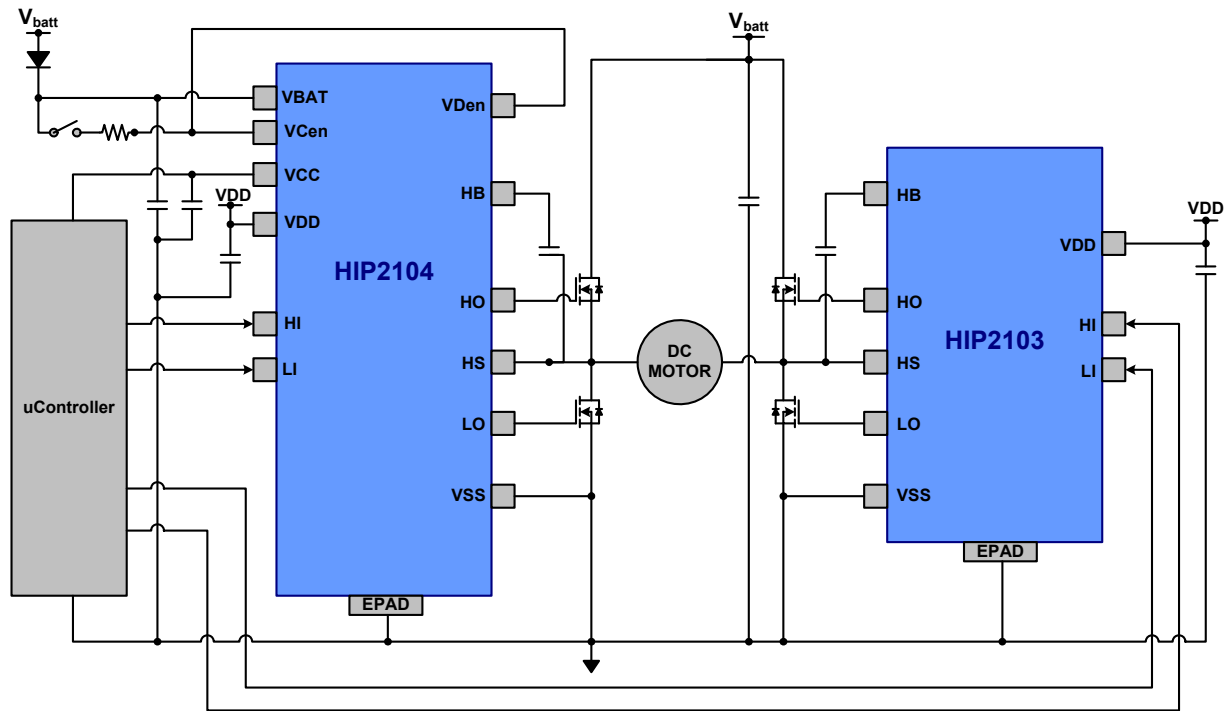

FIGURE 22. FULL BRIDGE MOTOR DRIVER TOPOLOGY

## Typical Applications

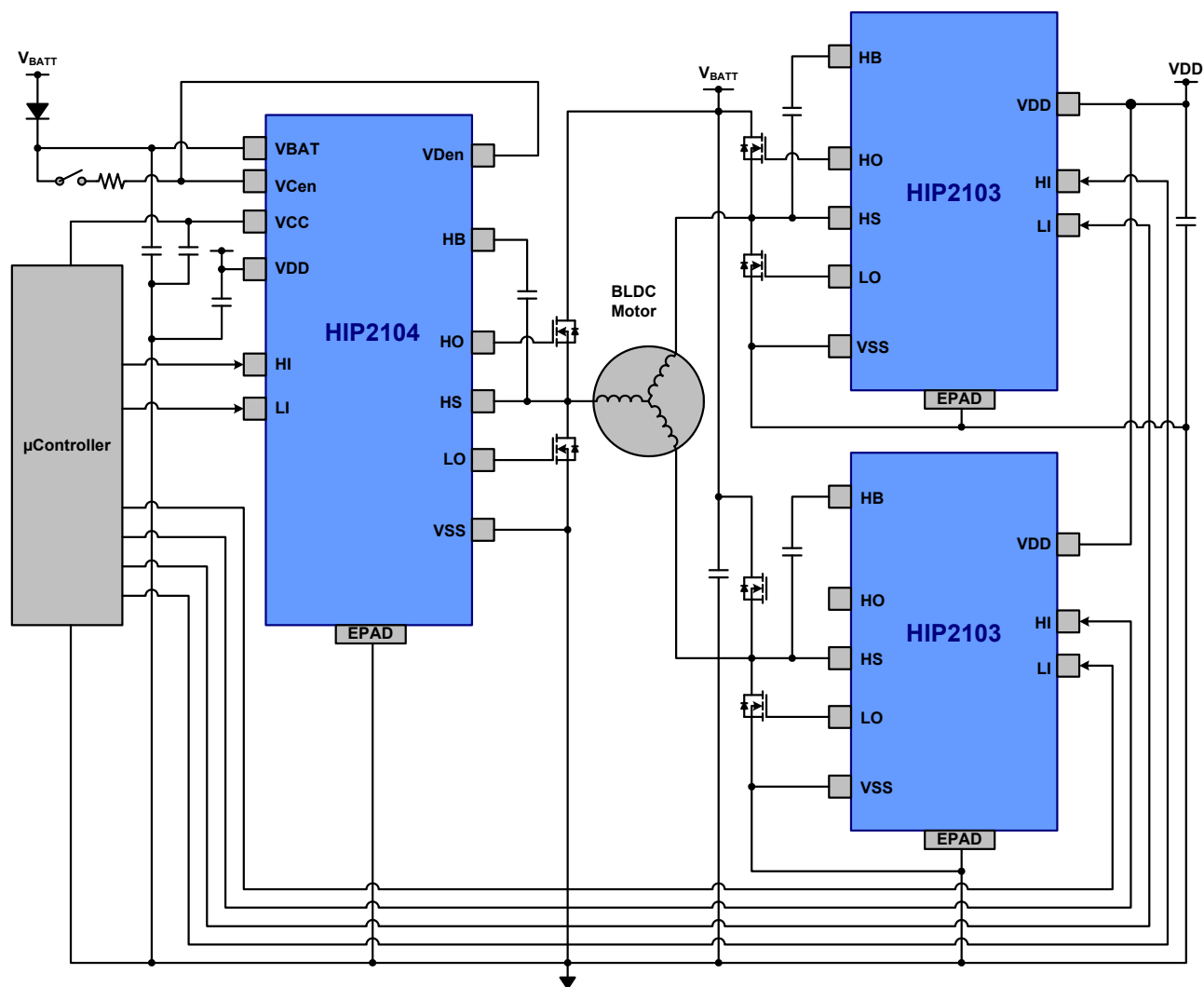

FIGURE 23. BLDC (3-PHASE) MOTOR DRIVE TOPOLOGY

## Application Examples

Above are examples (Figures 21, 22, and 23) of how the HIP2103, HIP2104 can be configured for various motor drive application with the HIP2104 supplying the 12V bias for the other HIP2103s and the V<sub>CC</sub> (3.3V) bias for the controller. VCen and VDen are used to turn on and off the internal linear regulators of the HIP2104. Because of entire switching of the bias supplies is implemented with logic, a signal switch, instead of a power switch, can be used to turn on and off the driver and controller. A switch debouncing delay of 1ms is provided on VDen and VCen.

The external diode on V<sub>BATT</sub> is used to hold up the voltage on the V<sub>BAT</sub> input in the presence of severe ripple as usually seen on LI-ON batteries.

In the case of the HIP2104, when VDen is low, the driver sections enters the Sleep Mode. When VCen is low, the bias to the controller is removed resulting with the lowest possible idle current in both the controller and the driver minimizing the drain on the battery when the motor drive is off. Sleep mode can also

be initiated on the HIP2104 by driving HI and LI high simultaneously. In this case, the sleep mode current is substantially higher (~250μA) because the V<sub>DD</sub> and V<sub>CC</sub> outputs are still active.

In the case of the HIP2103, Sleep Mode in the driver is initiated when HI and LI are both high simultaneously as previously described. If V<sub>DD</sub> is provided by an accompanying HIP2104, turning off the V<sub>DD</sub> output of the HIP2104 will also result with virtually no sleep current in the HIP2103 because there is no bias. For example, in the BLDC configuration, the sleep mode current will be ~5μA (in the HIP2104) and no current in both of the HIP2103s.

### Transients on the HS node

An important operating condition that is frequently overlooked is the transient on the HS pin that occurs when the bridge FETs turn on or off. The Absolute Maximum negative transient (see page 5) allowed on the HS pin is -10V without any time restrictions on the duration of the transient. In most well designed PCBs, all that will be required is that the transient be less negative than -10V.

# HIP2103, HIP2104

The negative transient on the HS pin is the result of the parasitic inductance of the low-side drain-source conductor path on the PCB. Even the parasitic inductance of the low-side FET body contributes to this transient. When the high-side bridge FET turns off (see Figure 24), as a consequence of the inductive characteristics of a motor load, the current that was flowing in the high-side FET (blue) must rapidly commutate through the low side FET (red). The amplitude of the negative transient impressed on the HS node is  $(L \times di/dt)$  where  $L$  is the total parasitic inductance of the low-side FET drain-source path and  $di/dt$  is the rate at which the high-side FET is turned off. With the increasing current levels of new generation motor drives, appropriately clamping of this transient becomes more significant for the proper operation of bridge drivers. Fortunately, the HIP2103, HIP2104 can withstand greater amplitudes of negative transients than what is available in many other bridge drivers. The maximum negative voltage on the HS pin is rated for -10V with no time during limit.

Another component of negative voltage is from the body diode of the low side FET during the dead time. When current is flowing from source to drain, the conduction voltage is approximately 1 to 1.5V negative impressed on the HS pin (possibly greater during fault load conditions). Because the HIP2103, HIP2104 is rated for -10V without any time constraints, this negative voltage component is of no consequence.

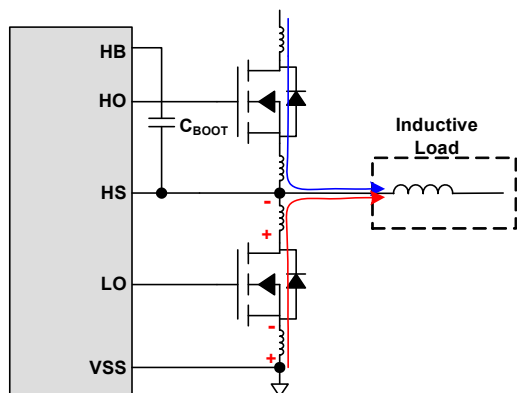

FIGURE 24. PARASITIC INDUCTANCE ON HS NODE

In the unlikely event that the negative transient exceeds -10V, there are several ways of reducing the negative amplitude of this transient if necessary. If the bridge FETs are turned off more slowly to reduce  $di/dt$ , the amplitude will be reduced but at the expense of more switching losses in the FETs. Careful PCB design will also reduce the value of the parasitic inductance. However, in extreme cases, these two solutions by themselves may not be sufficient. Figure 25 illustrates a simple method for clamping the negative transient. Two series connected, fast 1 amp PN junction diodes are connected between HS and VSS as shown. It is important that these diodes be placed as close as possible to the HS and VSS pins to minimize the parasitic inductance of this current path between the two pins. Two diodes in series are required because they are in parallel with the body diode of the low side FET. If only one diode is used for the clamp, it will conduct some of the negative load current that is flowing in the body diode of the low side FET.

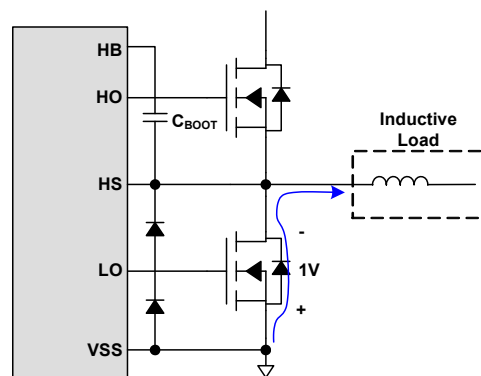

FIGURE 25. TWO CLAMPING DIODES TO SUPPRESS NEGATIVE TRANSIENTS

An alternative to the two series connected diodes is one diode and a resistor (Figure 26). In this case, it is necessary to limit the current in the diode with a small value resistor,  $R_{HS}$ , connected between the phase node of the 1/2 bridge and the HS pin. Observe that  $R_{HS}$  is effectively in series with the HO output and serves as a peak current limiting gate resistor on HO.

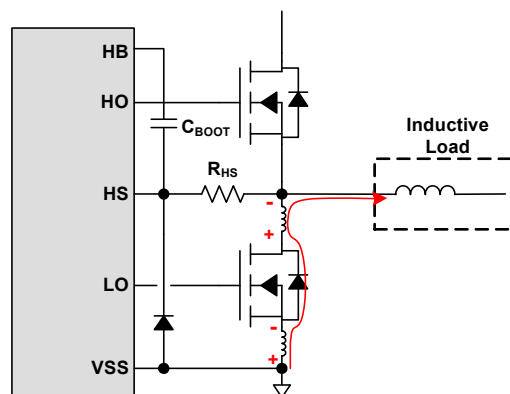
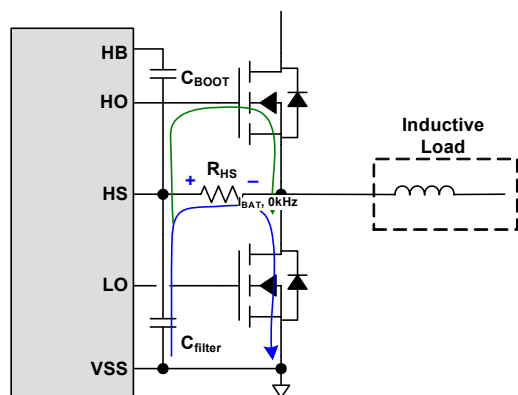

FIGURE 26. RESISTOR AND DIODE NEGATIVE TRANSIENT CLAMP

The value of  $R_{HS}$  is determined by how much average current in the clamping diode is acceptable. Current in the low side FET flows through the body diode during the dead time resulting with a negative voltage on HS that is typically about -1.5V. When the low-side FET is turned on, the current through the body diode is shunted away into the channel and the conduction voltage from source to drain is typically much less than the conduction voltage through the body diode. Consequently, significant current will flow in the clamping diode only during the dead time. Because the dead time is much less than the on time of the low side FET, the resulting average current in the clamping diode is very low. The value of  $R_{HS}$  is then chosen to limit the peak current in the clamping diode and usually just a few ohms is necessary.

The methods to clamp the negative transients with diodes can still result with high frequency oscillations on the HS node depending on the parasitics of the PCB design. An alternative to the clamping diode in Figure 26 is a small value capacitor instead of the diode. This capacitor and  $R_{HS}$  is very effective for minimizing the negative spike amplitude and oscillations.



**FIGURE 27. RESISTOR AND CAPACITOR NEGATIVE TRANSIENT FILTER**

But this solution also has its limitations. Depending on the value of the filter capacitor and the PWM switching frequency,  $R_{HS}$  may dissipate significant power because the voltage on the capacitor is switching between the bridge voltage and ground. Usually, the power dissipated by  $R_{HS}$  is small because the switching frequency for most motor drives is  $<20\text{kHz}$  and the value used for  $C_{filter}$  is typically about  $1000\text{pF}$ .

Another issue is that the charge on  $C_{filter}$  will be partially transferred to the gate of the high-side FET when the low-side FET turns on. When the phase node goes low, a voltage is impressed across  $R_{HS}$  as shown in Figure 27. Because HO is low, the voltage across  $R_{HS}$  is also across the gate of the high side FET. If the filter cap is very large, the voltage on the gate will approach the bridge voltage turning on the high-side FET resulting with shoot-through. Fortunately, the voltage across  $R_{HS}$  is much less than the bridge voltage for two reasons. First, the voltage across  $R_{HS}$  is determined by the turn-on time of the low side FET. As the low-side FET is turning on, the charge on the filter cap is depleting lessening the voltage across  $R_{HS}$ . Also, because the relatively large gate capacitance of the high-side FET is in parallel with  $R_{HS}$ , the voltage impressed on the gate is further reduced. In a practical application using value of  $C_{filter} = 4700\text{pF}$  and  $R_{HS} = 1\Omega$ , the voltage impressed on the bridge FET is less than  $1\text{V}$ .

The emphasis of suppressing transients on the HS pin has been with negative transients. Please note that a similar transients with a positive polarity occurs when the low-side FET turns off. This is usually not a problem unless the bridge voltage is close to the maximum rated operating voltage of  $50\text{V}$ . Note that the maximum voltage ratings for the HS and HB nodes also must be observed when the positive transient occurs.

The maximum rating for (VHB - VHS) must also not be overlooked. When a negative transient,  $V_{neg}$ , is present on the HS pin, the voltage differential across HB and HS will approach  $V_{DD} + V_{neg}$ . If the transient duration is short compared to the charging time constant of the boot diode and boot capacitor, the voltage across HB and HS is not significantly affected. However, another source of negative voltage on the HS pin will more likely increase the boot capacitor voltage. While current is flowing from the source to drain of the low-side FET during the dead time, the current flows through body diode of the FET. Depending on the size of the FET and the amplitude of the reverse current, the voltage across the diode can be as high as  $-1.5\text{V}$  and much higher during a load fault. Because this negative voltage has little

impedance, the boot capacitor can charge to a voltage greater than  $V_{DD}$  (for example  $V_{DD} + 1.5\text{V}$ ). It may be necessary to either clamp the voltage as described in Figures 25 through 27 and/or keep the dead time as short as possible.

## General PCB Layout Guidelines

The AC performance of the HIP2103, HIP2104 depends significantly on the design of the PC board. The following layout design guidelines are recommended to achieve optimum performance:

- Place the driver as close as possible to the driven power FET.
- Understand where the switching power currents flow. The high amplitude  $di/dt$  currents of the driven power FET will induce significant voltage transients on the associated traces.
- Keep power loops as short as possible by paralleling the source and return traces.
- Use planes where practical; they are usually more effective than parallel traces.
- Avoid paralleling high amplitude  $di/dt$  traces with low level signal lines. High  $di/dt$  will induce currents and consequently, noise voltages in the low level signal lines.
- When practical, minimize impedances in low level signal circuits. Noise, magnetically induced on a  $10\text{k}\Omega$  resistor, is  $10\times$  larger than the noise on a  $1\text{k}\Omega$  resistor.
- Be aware of magnetic fields emanating from motors and inductors. Gaps in the magnetic cores of these structures are especially bad for emitting flux.
- If you must have traces close to magnetic devices, align the traces so that they are parallel to the flux lines to minimize coupling.
- The use of low inductance components such as chip resistors and chip capacitors is highly recommended.
- Use decoupling capacitors to reduce the influence of parasitic inductance in the  $V_{BAT}$ ,  $V_{DD}$  and GND leads. To be effective, these caps must also have the shortest possible conduction paths. If vias are used, connect several paralleled vias to reduce the inductance of the vias.
- It may be necessary to add resistance to dampen resonating parasitic circuits especially on LO and LO. If an external gate resistor is unacceptable, then the layout must be improved to minimize lead inductance.
- Keep high  $dv/dt$  nodes away from low level circuits. Guard banding can be used to shunt away  $dv/dt$  injected currents from sensitive circuits.
- Avoid having a signal ground plane under a high amplitude  $dv/dt$  circuit. The parasitic capacitance of a ground plane,  $C_p$ , relative to the high amplitude  $dv/dt$  circuit will result in injected ( $C_p \times dv/dt$ ) currents into the signal ground paths where C is the parasitic capacitance of the ground plane.
- Do power dissipation and voltage drop calculations of the power traces. Many PCB/CAD programs have built in tools for calculation of trace resistance. The internet is also a good source for resistance calculators for PCB trace resistance.

# HIP2103, HIP2104

- Large power components (Power FETs, Electrolytic caps, power resistors, etc.) have internal parasitic inductance which cannot be eliminated. This must be accounted for in the PCB layout and circuit design.
- If you simulate your circuits, consider including parasitic components especially parasitic inductance.

## General EPAD Heatsinking Considerations

The EPAD of the HIP2103, HIP2104 is electrically connected to VSS through the IC substrate. The epad has two main functions: to provide a quiet signal ground and to provide heat sinking for the IC. The EPAD must be connected to a ground plane and switching currents from the driven FETs should not pass through the ground plane under the IC.

Figure 28 is a PCB layout example of how to use vias to remove heat from the IC through the EPAD.

For maximum heatsinking, it is recommended that a ground plane, connected to the EPAD, be added to both sides of the PCB. A via array, within the area of the EPAD, will conduct heat from the EPAD to the GND plane on the bottom layer. The number of

vias and the size of the GND planes required for adequate heatsinking is determined by the power dissipated by the HIP2103, HIP2104, the air flow, and the maximum temperature of the air around the IC.

Note that a separate plane is added under the high side drive circuits and is connected to HS. In a manner similar to the ground plane, the HS plane provides the lowest possible parasitic inductance for the HO/HS gate drive current loop.

See [AN1899](#) "HIP2103, HIP2104 3-phase, Full, or Half Bridge Motor Driver" for an example of PCB layout of a real application.

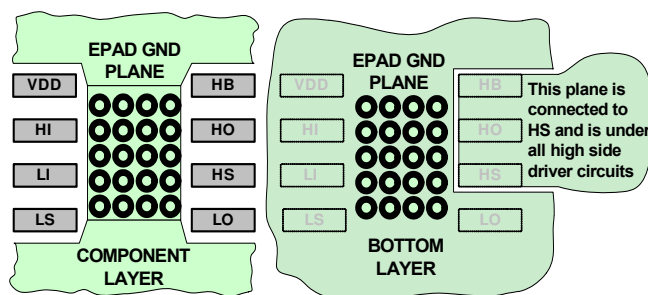

FIGURE 28. TYPICAL PCB PATTERN FOR THERMAL VIAS

## Revision History

The revision history provided is for informational purposes only and is believed to be accurate, but not warranted. Please go to the web to make sure that you have the latest revision.

DATE	REVISION	CHANGE
November 27, 2013	FN8276.0	Initial Release

## About Intersil

Intersil Corporation is a leading provider of innovative power management and precision analog solutions. The company's products address some of the largest markets within the industrial and infrastructure, mobile computing and high-end consumer markets.

For the most updated datasheet, application notes, related documentation and related parts, please see the respective product information page found at [www.intersil.com](http://www.intersil.com).

You may report errors or suggestions for improving this datasheet by visiting [www.intersil.com/ask](http://www.intersil.com/ask).

Reliability reports are also available from our website at [www.intersil.com/support](http://www.intersil.com/support)

For additional products, see [www.intersil.com/en/products.html](http://www.intersil.com/en/products.html)

Intersil products are manufactured, assembled and tested utilizing ISO9001 quality systems as noted in the quality certifications found at [www.intersil.com/en/support/qualandreliability.html](http://www.intersil.com/en/support/qualandreliability.html)

*Intersil products are sold by description only. Intersil Corporation reserves the right to make changes in circuit design, software and/or specifications at any time without notice. Accordingly, the reader is cautioned to verify that data sheets are current before placing orders. Information furnished by Intersil is believed to be accurate and reliable. However, no responsibility is assumed by Intersil or its subsidiaries for its use; nor for any infringements of patents or other rights of third parties which may result from its use. No license is granted by implication or otherwise under any patent or patent rights of Intersil or its subsidiaries.*

For information regarding Intersil Corporation and its products, see [www.intersil.com](http://www.intersil.com)

# HIP2103, HIP2104

## Package Outline Drawing

**L8.3x3A**

8 LEAD THIN DUAL FLAT NO-LEAD PLASTIC PACKAGE

Rev 4, 2/10

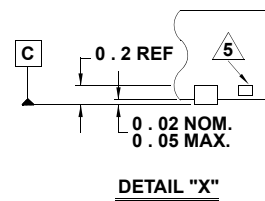
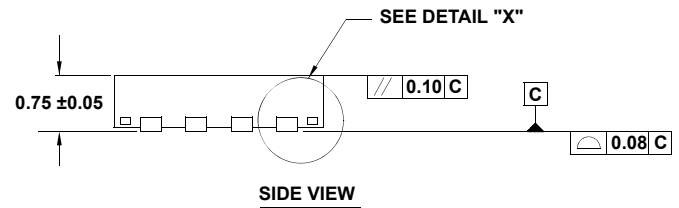
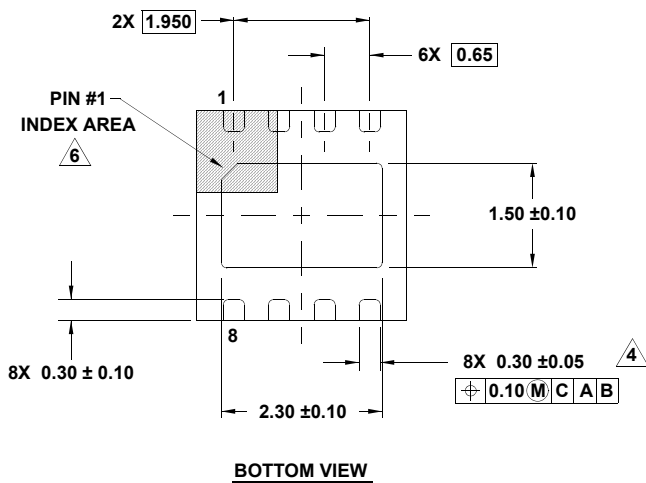
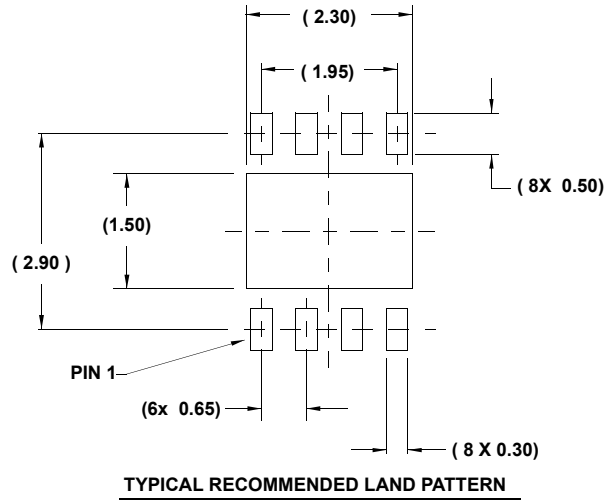
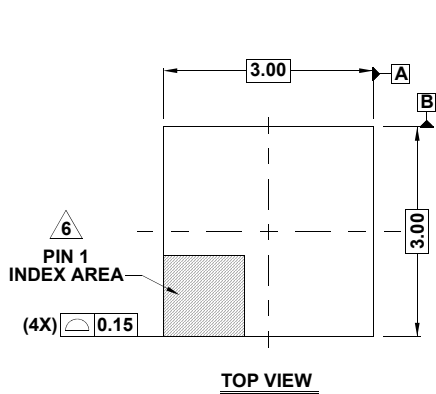

### NOTES:

1. Dimensions are in millimeters.  
Dimensions in ( ) for Reference Only.
2. Dimensioning and tolerancing conform to ASME Y14.5m-1994.
3. Unless otherwise specified, tolerance : Decimal  $\pm 0.05$
4. Dimension applies to the metallized terminal and is measured between 0.15mm and 0.20mm from the terminal tip.
5. Tiebar shown (if present) is a non-functional feature.
6. The configuration of the pin #1 identifier is optional, but must be located within the zone indicated. The pin #1 identifier may be either a mold or mark feature.
7. Compliant to JEDEC MO-229 WEEC-2 except for the foot length.

# HIP2103, HIP2104

## Package Outline Drawing

L12.4x4A

12 LEAD DUAL FLAT NO-LEAD PLASTIC PACKAGE

Rev 2, 6/12

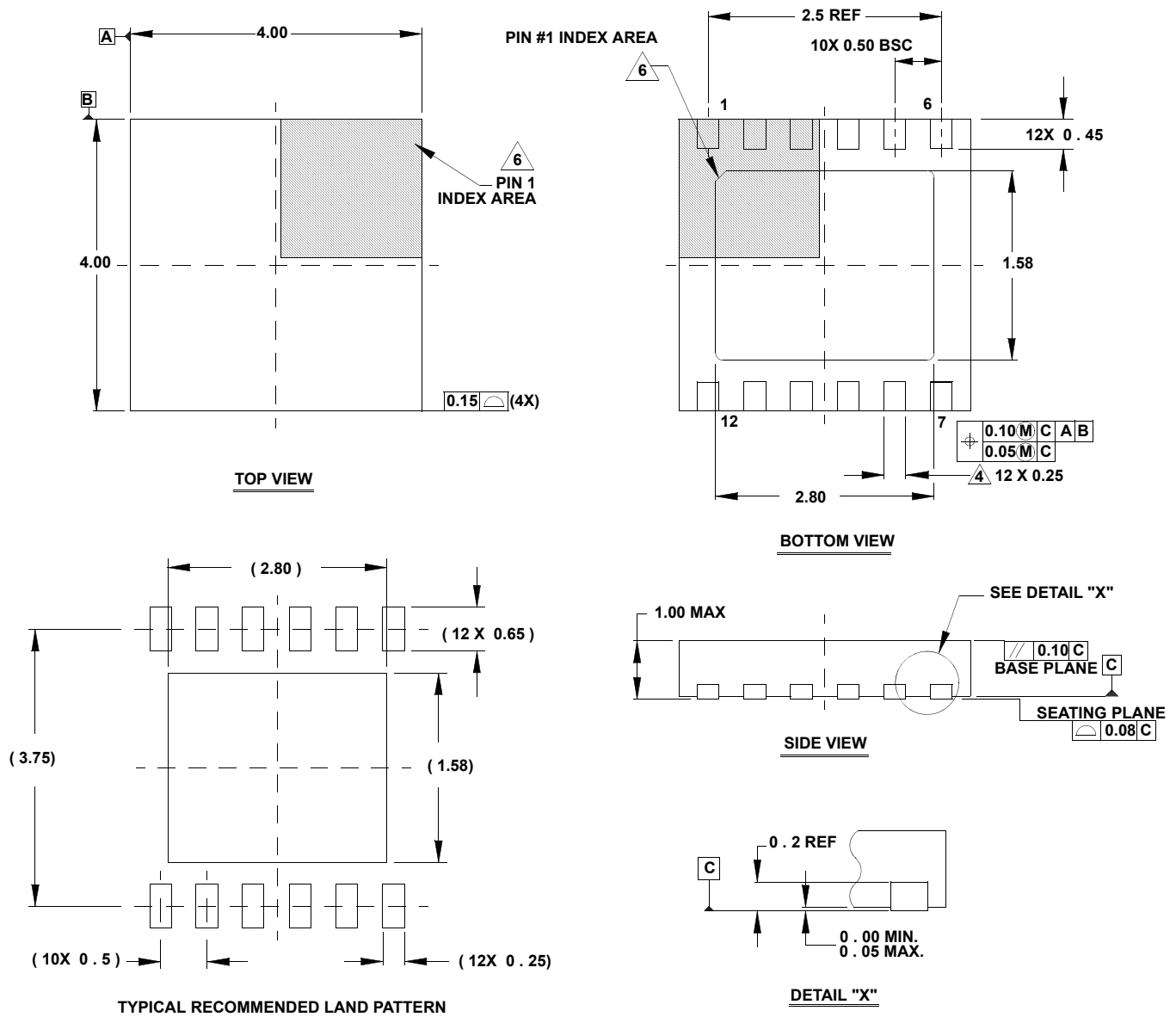

### NOTES:

1. Dimensions are in millimeters.  
Dimensions in ( ) for Reference Only.
2. Dimensioning and tolerancing conform to AMSE Y14.5m-1994.
3. Unless otherwise specified, tolerance : Decimal  $\pm 0.05$
4. Lead width applies to the metallized terminal and is measured between 0.15mm and 0.30mm from the terminal tip.
5. Tiebar shown (if present) is a non-functional feature.
6. The configuration of the pin #1 identifier is optional, but must be located within the zone indicated. The pin #1 identifier may be either a mold or mark feature.