



Chipsmall Limited consists of a professional team with an average of over 10 year of expertise in the distribution of electronic components. Based in Hongkong, we have already established firm and mutual-benefit business relationships with customers from,Europe,America and south Asia,supplying obsolete and hard-to-find components to meet their specific needs.

With the principle of “Quality Parts,Customers Priority,Honest Operation,and Considerate Service”,our business mainly focus on the distribution of electronic components. Line cards we deal with include Microchip,ALPS,ROHM,Xilinx,Pulse,ON,Everlight and Freescale. Main products comprise IC,Modules,Potentiometer,IC Socket,Relay,Connector.Our parts cover such applications as commercial,industrial, and automotives areas.

We are looking forward to setting up business relationship with you and hope to provide you with the best service and solution. Let us make a better world for our industry!



## Contact us

Tel: +86-755-8981 8866 Fax: +86-755-8427 6832

Email & Skype: info@chipsmall.com Web: www.chipsmall.com

Address: A1208, Overseas Decoration Building, #122 Zhenhua RD., Futian, Shenzhen, China



# 80V, 500mA, 3-Phase MOSFET Driver

## HIP4086, HIP4086A

The [HIP4086](#) and [HIP4086A](#) (referred to as the HIP4086/A) are 3-phase N-channel MOSFET drivers. Both parts are specifically targeted for PWM motor control. These drivers have flexible input protocol for driving every possible switch combination. The user can even override the shoot-through protection for switched reluctance applications.

The HIP4086/A have a wide range of programmable dead times (0.5µs to 4.5µs) which makes them very suitable for the low frequencies (up to 100kHz) typically used for motor drives.

The only difference between the HIP4086 and the HIP4086A is that the HIP4086A has the built-in charge pumps disabled. This is useful in applications that require very quiet EMI performance (the charge pumps operate at 10MHz). The advantage of the HIP4086 is that the built-in charge pumps allow indefinitely long on times for the high-side drivers.

To insure that the high-side driver boot capacitors are fully charged prior to turning on, a programmable bootstrap refresh pulse is activated when VDD is first applied. When active, the refresh pulse turns on all three of the low-side bridge FETs while holding off the three high-side bridge FETs to charge the high-side boot capacitors. After the refresh pulse clears, normal operation begins.

Another useful feature of the HIP4086/A is the programmable undervoltage set point. The set point range varies from 6.6V to 8.5V.

TABLE 1. KEY DIFFERENCES BETWEEN FAMILY OF PARTS

PART NUMBER	CHARGE PUMP
HIP4086	Yes
HIP4086A	No

## Features

- Independently drives 6 N-channel MOSFETs in 3-phase bridge configuration
- Bootstrap supply maximum voltage up to 95VDC with bias supply from 7V to 15V
- 1.25A peak turn-off current
- User programmable dead time (0.5µs to 4.5µs)
- Bootstrap and optional charge pump maintain the high-side driver bias voltage.
- Programmable bootstrap refresh time
- Drives 1000pF load with typical rise time of 20ns and fall time of 10ns
- Programmable undervoltage set point

## Applications

- Brushless Motors (BLDC)
- 3-phase AC motors
- Switched reluctance motor drives
- Battery powered vehicles
- Battery powered tools

## Related Literature

- [AN9642](#), "HIP4086 3-Phase Bridge Driver Configurations and Applications"
- [AN1829](#), "HIP4086 3-Phase BLDC Motor Drive Demonstration Board, User Guide"

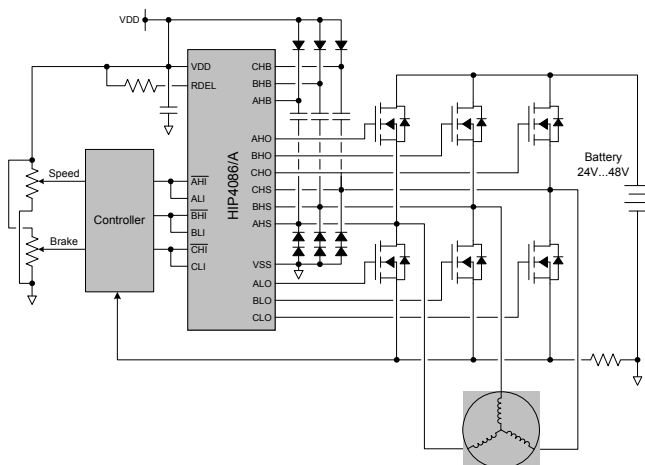

FIGURE 1. TYPICAL APPLICATION

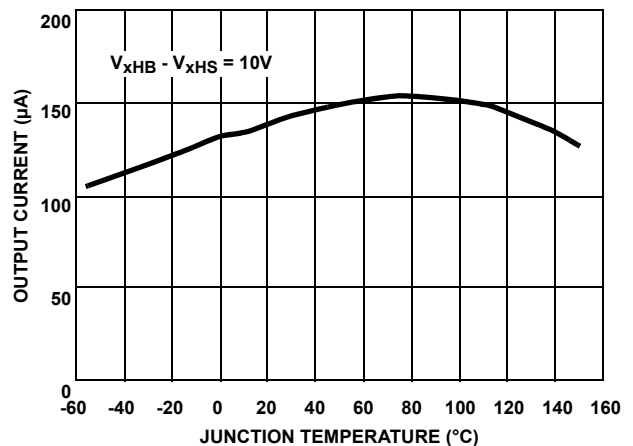

FIGURE 2. CHARGE PUMP OUTPUT CURRENT

# HIP4086, HIP4086A

## Block Diagram (for clarity, only one phase is shown)

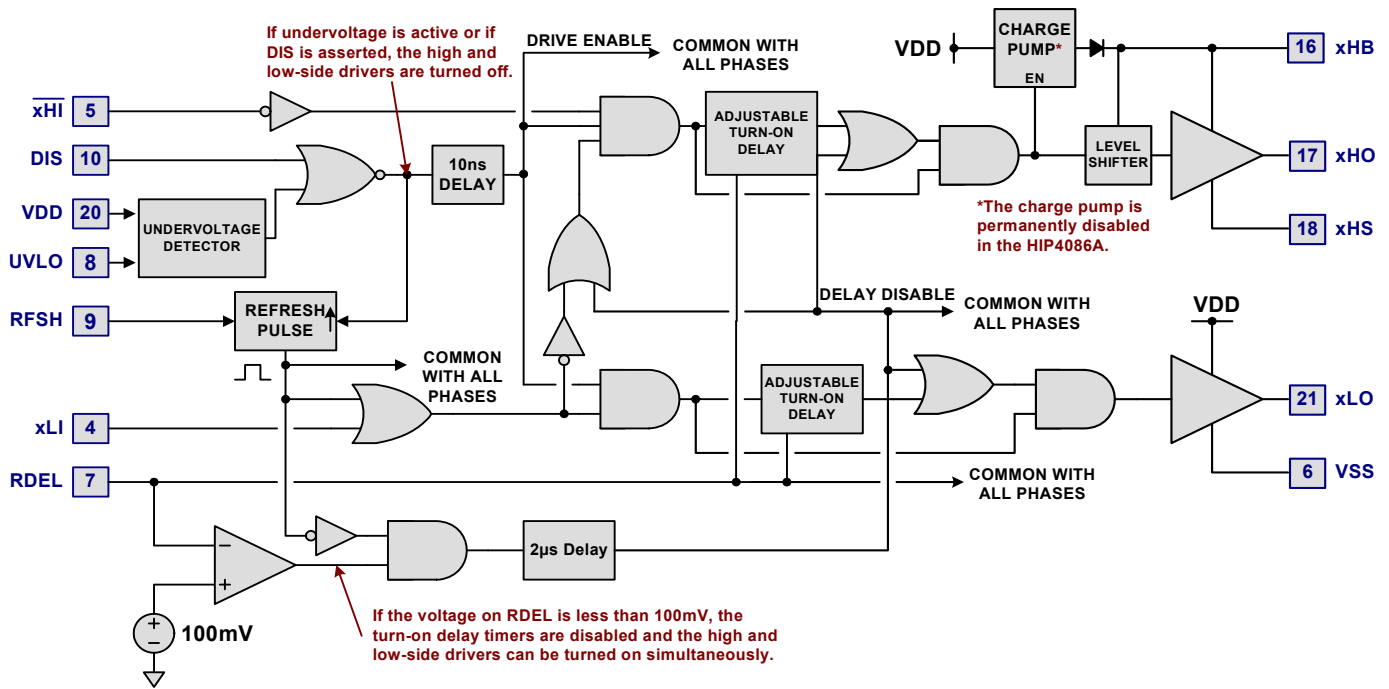

FIGURE 3. BLOCK DIAGRAM

## Truth Table

INPUT			OUTPUT			
ALI, BLI, CLI	AHI, BHI, CHI	UV	DIS	RDEL	ALO, BLO, CLO	AHO, BHO, CHO
X	X	X	1	X	0	0
X	X	1	X	X	0	0
1	X	0	0	>100mV	1	0
0	0	0	0	X	0	1
0	1	0	0	X	0	0
1	0	0	0	<100mV	1	1

NOTE: X signifies that input can be either a "1" or "0".

# HIP4086, HIP4086A

## Pin Configuration

HIP4086, HIP4086A  
(24 LD PDIP, SOIC)  
TOP VIEW

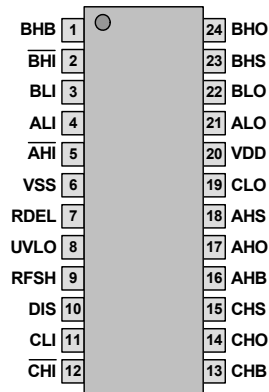

## Pin Descriptions

PIN NUMBER	SYMBOL	DESCRIPTION
16 1 13	AHB BHB CHB (xHB)	High-Side Bias Connections. One external bootstrap diode and one capacitor are required for each. Connect cathode of bootstrap diode and positive side of bootstrap capacitor to each xHB pin.
18 23 15	AHS BHS CHS (xHS)	High-Side Source Connections. Connect the sources of the high-side power MOSFETs to these pins. The negative side of the bootstrap capacitors are also connected to these pins.
5 2 12	$\overline{\text{AHI}}$ $\overline{\text{BHI}}$ $\overline{\text{CHI}}$ (xHI)	High-Side Logic Level Inputs. Logic at these three pins controls the three high-side output drivers, AHO (Pin 17), BHO (Pin 24) and CHO (Pin 14). When $\overline{\text{xHI}}$ is low, xHO is high. When $\overline{\text{xHI}}$ is high, xHO is low. Unless the dead time is disabled by connecting RDEL (Pin 7) to ground, the low-side input of each phase will override the corresponding high-side input on that phase - see <a href="#">"Truth Table" on page 2</a> . If RDEL is tied to ground, dead time is disabled and the outputs follow the inputs with no shoot-through protection. DIS (Pin 10) also overrides the high-side inputs. $\overline{\text{xHI}}$ can be driven by signal levels of 0V to 15V (no greater than $V_{DD}$ ).
4 3 11	ALI BLI CLI (xLI)	Low-Side Logic Level Inputs. Logic at these three pins controls the three low-side output drivers ALO (Pin 21), BLO (Pin 22) and CLO (Pin 19). If the upper inputs are grounded then the lower inputs control both xLO and xHO drivers, with the dead time set by the resistor at RDEL (Pin 7). DIS (Pin 10) high level input overrides xLI, forcing all outputs low. xLI can be driven by signal levels of 0V to 15V (no greater than $V_{DD}$ ).
6	VSS	Ground. Connect the sources of the low-side power MOSFETs to this pin.
7	RDEL	Delay Time Set Point. Connect a resistor from this pin to $V_{DD}$ to set timing current that defines the dead time between drivers - see <a href="#">Figure 19 on page 10</a> . All drivers turn off with minimal delay, RDEL resistor prevents shoot-through by delaying the turn-on of all drivers. When RDEL is tied to VSS, both upper and lowers can be commanded on simultaneously. While not necessary in most applications, a decoupling capacitor of 0.1 $\mu$ F or smaller may be connected between RDEL and VSS.
8	UVLO	Undervoltage Set Point. A resistor can be connected between this pin and VSS to program the undervoltage set point - see <a href="#">Figure 20 on page 10</a> . With this pin not connected, the under voltage disable is typically 6.6V. When this pin is tied to VDD, the under voltage disable is typically 6.2V.
9	RFSH	Refresh Pulse Setting. An external capacitor can be connected from this pin to VSS to increase the length of the start up refresh pulse - see <a href="#">Figure 18 on page 9</a> . If this pin is not connected, the refresh pulse is typically 1.5 $\mu$ s.

# HIP4086, HIP4086A

## Pin Descriptions (Continued)

PIN NUMBER	SYMBOL	DESCRIPTION
10	DIS	Disable Input. Logic level input that when taken high sets all six outputs low. DIS high overrides all other inputs. With DIS low, the outputs are controlled by the other inputs. DIS can be driven by signal levels of 0V to 15V (no greater than $V_{DD}$ ).
17 24 14	AHO BHO CHO (xHO)	High-Side Outputs. Connect to the gates of the high-side power MOSFETs in each phase.
20	VDD	Positive Supply. Decouple this pin to VSS (Pin 6).
21 22 19	ALO BLO CLO (xLO)	Low-Side Outputs. Connect the gates of the low-side power MOSFETs to these pins.

NOTE: x = A, B or C.

## Ordering Information

PART NUMBER (Note 3)	PART MARKING	TEMP RANGE (°C)	CHARGE PUMP	PACKAGE	PKG. DWG. #
HIP4086AB (Note 1)	HIP4086AB	-40 to +125	Yes	24 Ld SOIC	M24.3
HIP4086ABZ (Notes 1, 2)	HIP4086ABZ	-40 to +125	Yes	24 Ld SOIC (RoHS Compliant)	M24.3
HIP4086APZ (Note 2)	HIP4086APZ	-40 to +125	Yes	24 Ld PDIP (RoHS Compliant)	E24.3
HIP4086AABZ (Notes 1, 2)	HIP4086AABZ	-40 to +125	No	24 Ld SOIC (RoHS Compliant)	M24.3
HIP4086DEM01Z	HIP4086 Demonstration Board				

NOTES:

1. Add "T", suffix for 1k unit tape and reel option. Please refer to [TB347](#) for details on reel specifications.
2. These Intersil Pb-free plastic packaged products employ special Pb-free material sets, molding compounds/die attach materials, and 100% matte tin plate plus anneal (e3 termination finish, which is RoHS compliant and compatible with both SnPb and Pb-free soldering operations). Intersil Pb-free products are MSL classified at Pb-free peak reflow temperatures that meet or exceed the Pb-free requirements of IPC/JEDEC J STD-020.
3. For Moisture Sensitivity Level (MSL), please see device information page for [HIP4086](#), [HIP4086A](#). For more information on MSL, please see Technical Brief [TB363](#).

# HIP4086, HIP4086A

## Absolute Maximum Ratings [\(Note 7\)](#)

Supply Voltage, $V_{DD}$ Relative to GND	-0.3V to 16V
Logic Inputs (xLI, xHI)	(GND - 0.3V) to $V_{DD} + 0.3V$
Voltage on xHS	-6V (Transient) to 85V (-40°C to +150°C)
Voltage on xHB	( $V_{xHS} - 0.3V$ ) to $V_{xHS} + V_{DD}$
Voltage on xLO	( $V_{SS} - 0.3V$ ) to $V_{DD} + 0.3V$
Voltage on xHO	( $V_{xHS} - 0.3V$ ) to $V_{xHB} + 0.3V$
Phase Slew Rate (on xHS)	20V/ns

## Maximum Recommended Operating Conditions

Supply Voltage, $V_{DD}$ Relative to GND	7V to 15V
Logic Inputs (xLI, xHI)	0V to $V_{DD}$
Voltage on xHB	$V_{xHS} + V_{DD}$
Voltage on xHS	0V to 80V
Ambient Temperature Range	-40°C to +125°C
Junction Temperature Range	-40°C to +150°C
RDEL range	10kΩ to 100kΩ

**CAUTION:** Do not operate at or near the maximum ratings listed for extended periods of time. Exposure to such conditions may adversely impact product reliability and result in failures not covered by warranty.

### NOTES:

- $\theta_{JA}$  is measured with the component mounted on a low effective thermal conductivity test board in free air. See Tech Brief [TB379](#) for details.
- $\theta_{JA}$  is measured with the component mounted on a high effective thermal conductivity test board in free air. See Tech Brief [TB379](#) for details.
- For  $\theta_{JC}$ , the “case temp” location is taken at the package top center.
- Replace x with A, B, or C.

## Thermal Information

Thermal Resistance (Typical)	$\theta_{JA}$ (°C/W)	$\theta_{JC}$ (°C/W)
SOIC Package ( <a href="#">Notes 4, 6</a> )	75	22
SOIC Package HIP4086AABZ ( <a href="#">Notes 5, 6</a> )	51	22
PDIP* Package ( <a href="#">Notes 4, 6</a> )	70	29
Storage Temperature Range	-65°C to +150°C	
Operating Junction Temp Range	-40°C to +150°C	
Pb-Free Reflow Profile	see <a href="#">TB493</a>	

\*Pb-free PDIPs can be used for through-hole wave solder processing only. They are not intended for use in Reflow solder processing applications.

**DC Electrical Specifications**  $V_{DD} = V_{xHB} = 12V$ ,  $V_{SS} = V_{xHS} = 0V$ ,  $R_{DEL} = 20k$ ,  $R_{UV} = \infty$ , Gate Capacitance ( $C_{GATE}$ ) = 1000pF, unless otherwise specified. **Boldface limits apply across the operating junction temperature range, -40°C to +150°C.**

PARAMETER	TEST CONDITIONS	$T_J = +25^\circ\text{C}$			$T_J = -40^\circ\text{C TO } +150^\circ\text{C}$		UNIT
		MIN <a href="#">(Note 9)</a>	TYP	MAX <a href="#">(Note 9)</a>	MIN <a href="#">(Note 9)</a>	MAX <a href="#">(Note 9)</a>	
<b>SUPPLY CURRENTS</b>							
$V_{DD}$ Quiescent Current	$\overline{xHI} = 5V$ , $xLI = 5V$ (HIP4086)	2.7	3.4	5.1	<b>1.96</b>	<b>5.3</b>	mA
	$\overline{xHI} = 5V$ , $xLI = 5V$ (HIP4086A)	2.3	2.8	3.1	<b>1.8</b>	<b>3.3</b>	mA
$V_{DD}$ Operating Current	$f = 20\text{kHz}$ , 50% Duty Cycle (HIP4086)	5.4	8.25	13	<b>4</b>	<b>13.5</b>	mA
	$f = 20\text{kHz}$ , 50% Duty Cycle (HIP4086A)	3.1	4.0	4.6	<b>2.7</b>	<b>5.1</b>	mA
xHB On Quiescent Current	$\overline{xHI} = 0V$ (HIP4086)	-	40	110	-	<b>140</b>	μA
	$\overline{xHI} = 0V$ (HIP4086A)	-	90	115	-	<b>225</b>	μA
xHB Off Quiescent Current	$\overline{xHI} = V_{DD}$ (HIP4086)	0.6	0.8	1.3	<b>0.5</b>	<b>1.4</b>	mA
	$\overline{xHI} = V_{DD}$ (HIP4086A)	0.8	1.0	1.2	<b>0.7</b>	<b>1.25</b>	mA
xHB Operating Current	$f = 20\text{kHz}$ , 50% Duty Cycle (HIP4086)	0.7	0.9	1.3	-	<b>2.0</b>	mA
	$f = 20\text{kHz}$ , 50% Duty Cycle (HIP4086A)	0.8	0.9	1.1	-	<b>1.25</b>	mA
xHB, xHS Leakage Current	$V_{xHS} = 80V$ , $V_{xHB} = 93V$	7	30	45	-	<b>50</b>	μA
<b>Charge Pump, HIP4086 Only, <a href="#">(Note 8)</a></b>							
QPUMP Output Voltage	No Load	11	12.5	14.6	<b>10</b>	<b>14.75</b>	V
QPUMP Output Current	$V_{xHS} = 12V$ , $V_{xHB} = 22V$	40	100	160	-	<b>185</b>	μA
<b>UNDERVOLTAGE PROTECTION</b>							
$V_{DD}$ Rising Undervoltage Threshold	$R_{UV}$ open	6.2	7.1	8.0	<b>6.1</b>	<b>8.1</b>	V
$V_{DD}$ Falling Undervoltage Threshold	$R_{UV}$ open	5.75	6.6	7.5	<b>5.6</b>	<b>7.6</b>	V
Minimum Undervoltage Threshold	$R_{UV} = V_{DD}$	5	6.2	6.8	<b>4.8</b>	<b>6.9</b>	V

# HIP4086, HIP4086A

**DC Electrical Specifications**  $V_{DD} = V_{xHB} = 12V$ ,  $V_{SS} = V_{xHS} = 0V$ ,  $R_{DEL} = 20k$ ,  $R_{UV} = \infty$ , Gate Capacitance ( $C_{GATE}$ ) = 1000pF, unless otherwise specified. **Boldface limits apply across the operating junction temperature range, -40°C to +150°C. (Continued)**

PARAMETER	TEST CONDITIONS	$T_J = +25^\circ C$			$T_J = -40^\circ C \text{ TO } +150^\circ C$		UNIT
		MIN (Note 9)	TYP	MAX (Note 9)	MIN (Note 9)	MAX (Note 9)	
<b>INPUT PINS: ALI, BLI, CLI, AHI, BHI, CHI, AND DIS</b>							
Low Level Input Voltage		-	-	1.0	-	<b>0.8</b>	V
High Level Input Voltage		2.5	-	-	<b>2.7</b>	-	V
Input Voltage Hysteresis		-	35	-	-	-	mV
Low Level Input Current	$V_{IN} = 0V$	-60	-100	-155	<b>-55</b>	<b>-165</b>	$\mu A$
High Level Input Current	$V_{IN} = 5V$	-1	-	+1	<b>-10</b>	<b>+10</b>	$\mu A$
<b>GATE DRIVER OUTPUT PINS: ALO, BLO, CLO, AHO, BHO, AND CHO</b>							
Low Level Output Voltage ( $V_{OUT} - V_{SS}$ )	$I_{SINKING} = 30mA$	-	100	-	-	<b>210</b>	mV
Peak Turn-On Current	$V_{OUT} = 0V$	0.3	0.5	0.7	-	<b>1.0</b>	A

NOTES:

- The specified charge pump current is the total amount available to drive external loads across xHO and xHS.
- Compliance to datasheet limits is assured by one or more methods: production test, characterization and/or design.

**AC Electrical Specifications**  $V_{DD} = V_{xHB} = 12V$ ,  $V_{SS} = V_{xHS} = 0V$ ,  $C_{GATE} = 1000pF$ ,  $R_{DEL} = 10k$ , unless otherwise specified. **Boldface limits apply across the operating junction temperature range, -40°C to +150°C.**

PARAMETER	TEST CONDITIONS	$T_J = +25^\circ C$			$T_J = -40^\circ C \text{ TO } +150^\circ C$		UNIT
		MIN (Note 9)	TYP	MAX (Note 9)	MIN (Note 9)	MAX (Note 9)	
<b>TURN-ON DELAY AND PROPAGATION DELAY</b>							
Dead Time (Figure 4)	$R_{DEL} = 100k\Omega$	3	4.5	7.2	<b>3</b>	<b>8</b>	$\mu s$
	$R_{DEL} = 10k\Omega$	0.38	0.5	0.75	<b>0.3</b>	<b>0.8</b>	$\mu s$
Dead Time Channel Matching	$R_{DEL} = 10k\Omega$	-	7	15	-	<b>20</b>	%
Lower Turn-Off Propagation Delay (xLI to xLO Turn-Off) (Figures 4 or 5)	No load	-	30	55	-	<b>75</b>	ns
Upper Turn-Off Propagation Delay (xHI to xHO Turn-Off) (Figures 4 or 5)	No load	-	75	110	-	<b>135</b>	ns
Lower Turn-On Propagation Delay (xLI to xLO Turn-On) (Figures 4 or 5)	No load	-	45	82	-	<b>100</b>	ns
Upper Turn-On Propagation Delay (xHI to xHO Turn-On) (Figures 4 or 5)	No load	-	65	110	-	<b>158</b>	ns
Rise Time	$C_{GATE} = 1000pF$	-	20	40	-	<b>60</b>	ns
Fall Time	$C_{GATE} = 1000pF$	-	10	20	-	<b>40</b>	ns
Disable Lower Turn-Off Propagation Delay ( $\overline{DIS}$ to xLO turn-off) (Figure 6)		-	55	80	-	<b>104</b>	ns
Disable Upper Turn-Off Propagation Delay ( $\overline{DIS}$ to xHO turn-off) (Figure 6)		-	80	116	-	<b>147</b>	ns
Disable to Lower Turn-On Propagation Delay ( $\overline{DIS}$ to xLO turn-on) (Figure 6)		-	55	85	-	<b>120</b>	ns
Disable to Upper Turn-On Propagation Delay ( $\overline{DIS}$ to xHO turn-on) (Figure 6)	$R_{DEL} = 10k\Omega$ , $C_{RFSH}$ open	-	2.0	-	-	-	$\mu s$

## Test Waveforms and Timing Diagrams

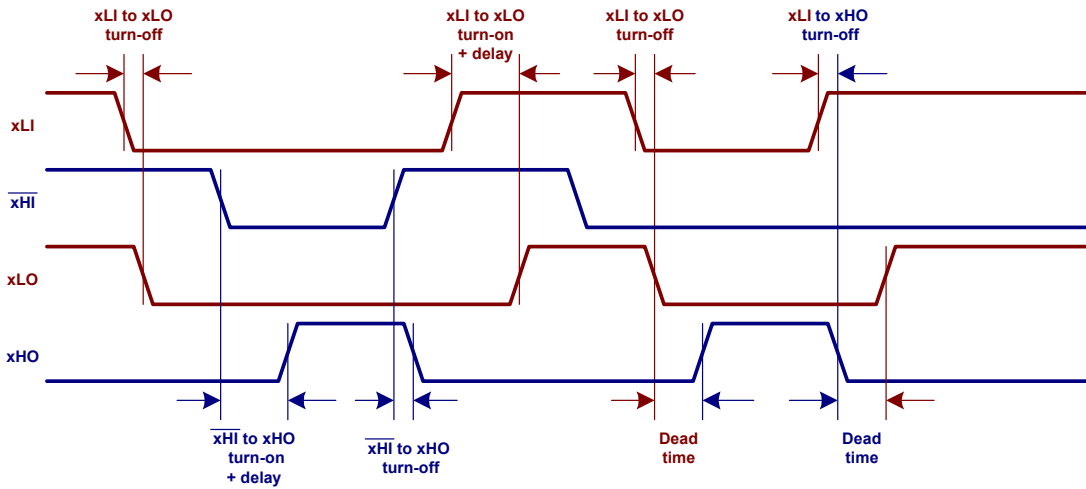

FIGURE 4. PROPAGATION DELAYS WITH PROGRAMMED TURN-ON DELAYS (RDEL CONNECTED TO VDD WITH A RESISTOR)

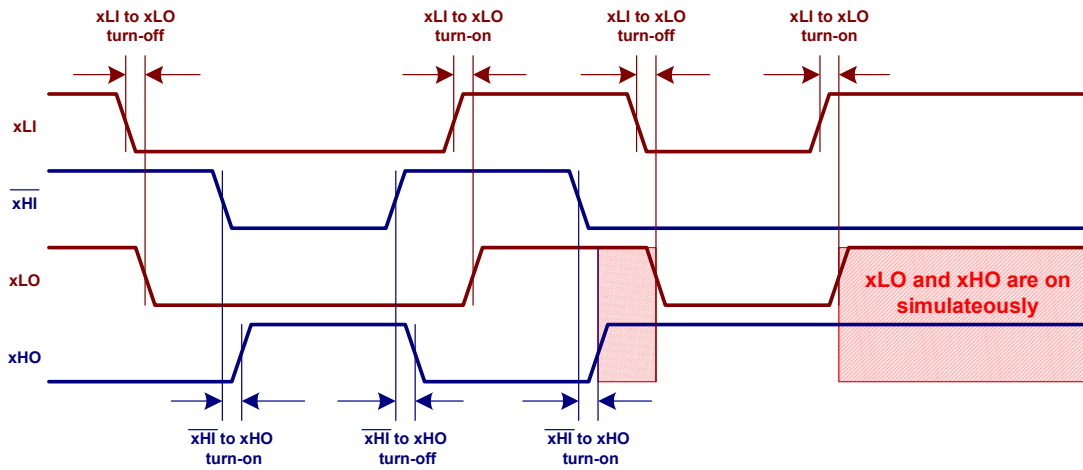

FIGURE 5. PROPAGATION DELAYS WITH NO PROGRAMMED TURN-ON DELAYS (RDEL CONNECTED TO VSS)

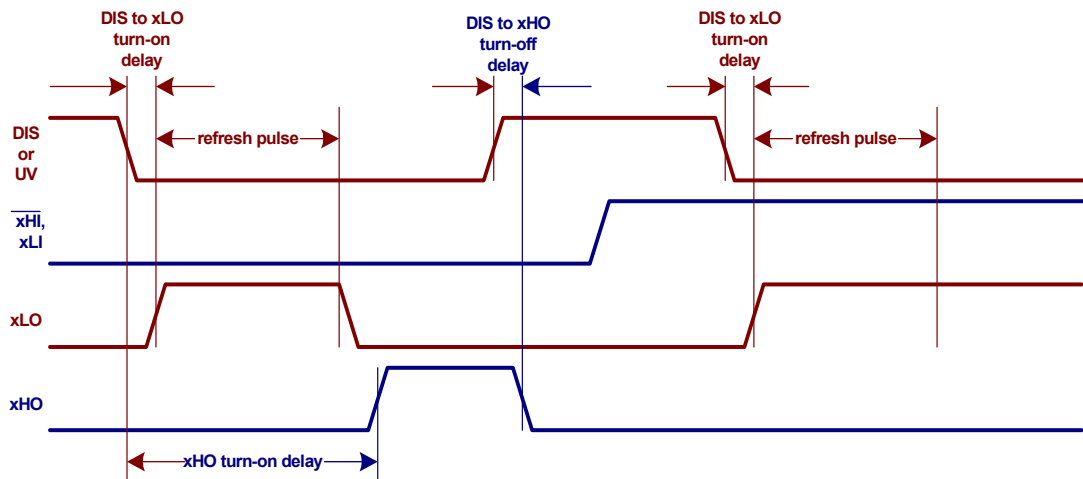

FIGURE 6. DISABLE FUNCTION

## Typical Performance Curves

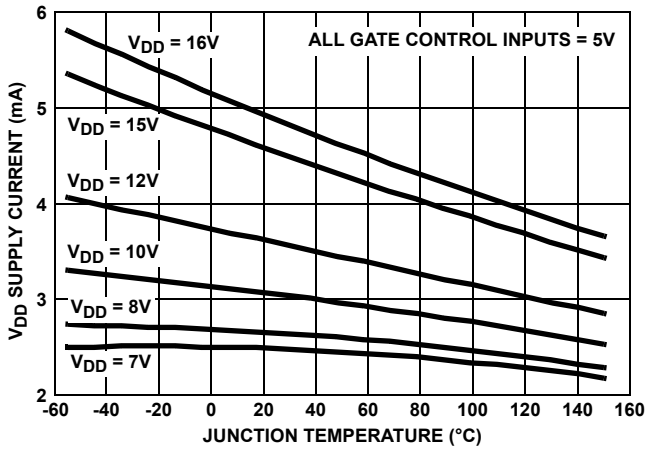

FIGURE 7.  $V_{DD}$  SUPPLY CURRENT vs  $V_{DD}$  SUPPLY VOLTAGE

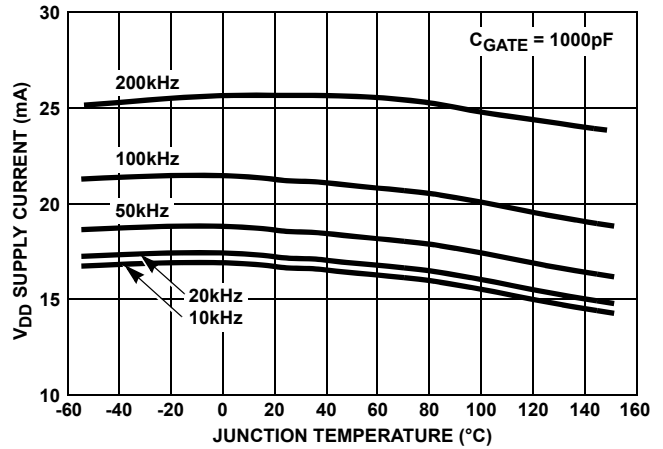

FIGURE 8.  $V_{DD}$  SUPPLY CURRENT vs SWITCHING FREQUENCY

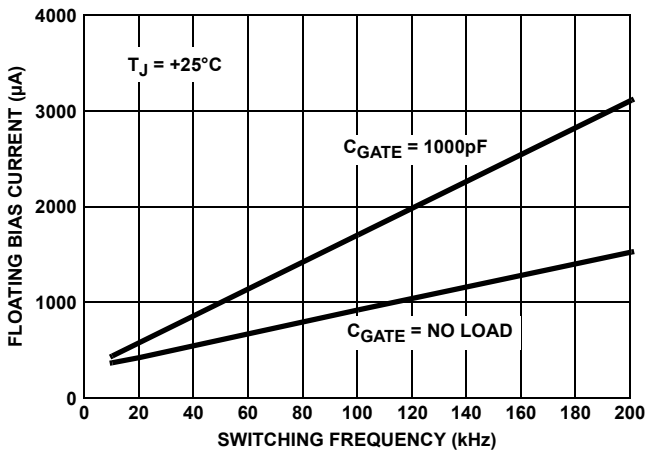

FIGURE 9. FLOATING  $I_{xHB}$  BIAS CURRENT

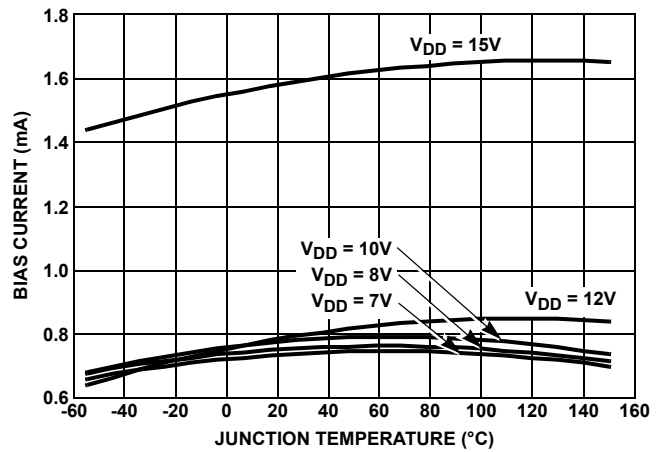

FIGURE 10. OFF-STATE  $I_{xHB}$  BIAS CURRENT

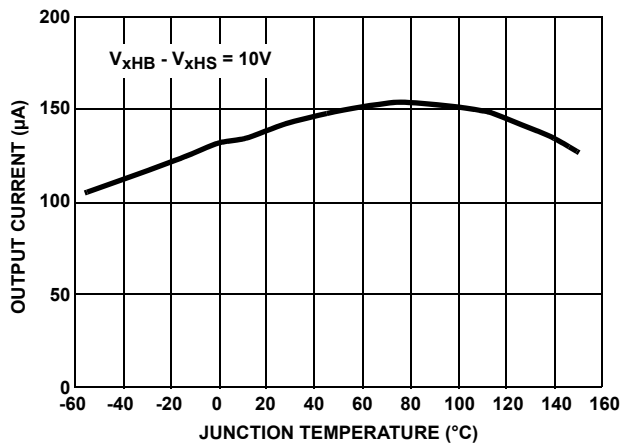

FIGURE 11. CHARGE PUMP OUTPUT CURRENT (HIP4086 ONLY)

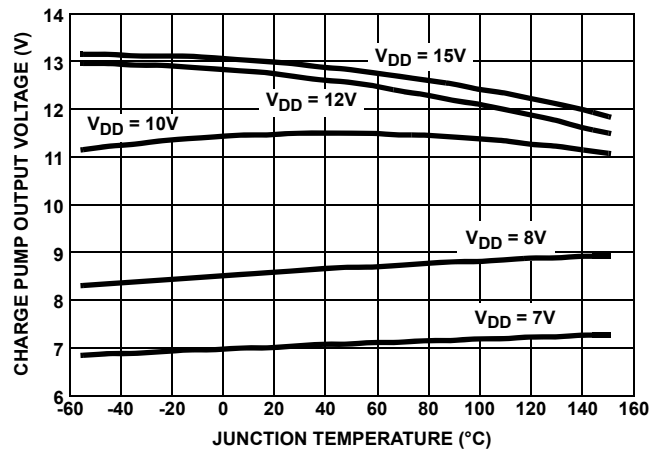

FIGURE 12. CHARGE PUMP OUTPUT VOLTAGE (HIP4086 ONLY)

# HIP4086, HIP4086A

## Typical Performance Curves (Continued)

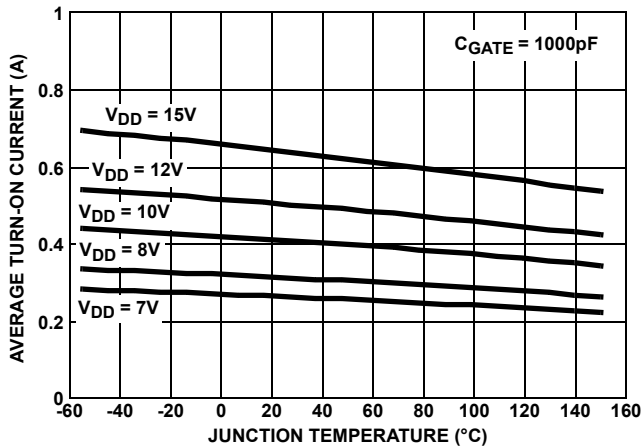

FIGURE 13. AVERAGE TURN-ON CURRENT (0 TO 5V)

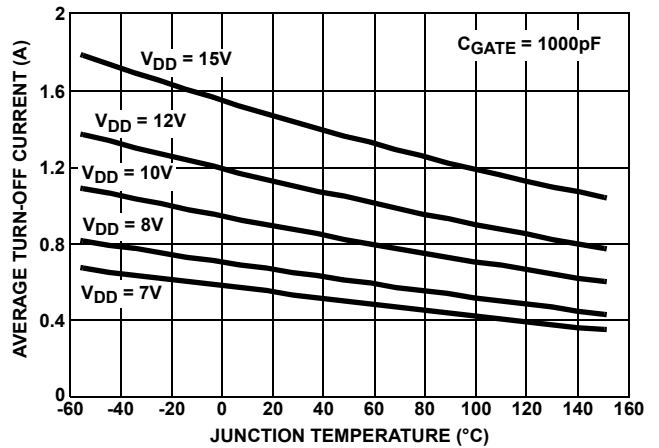

FIGURE 14. AVERAGE TURN-OFF CURRENT ( $V_{DD}$  TO 4V)

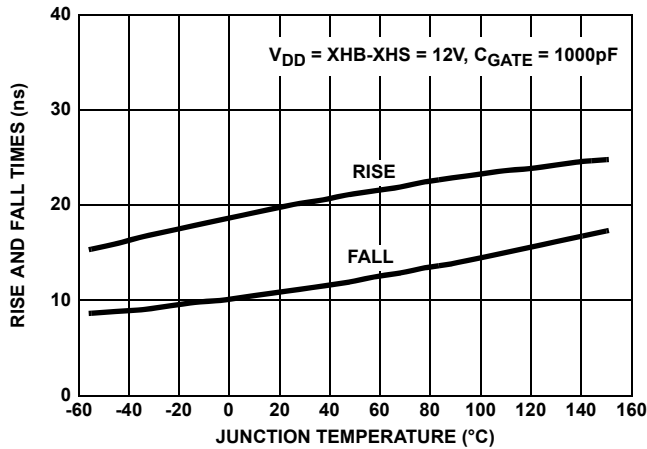

FIGURE 15. RISE AND FALL TIMES (10 TO 90%)

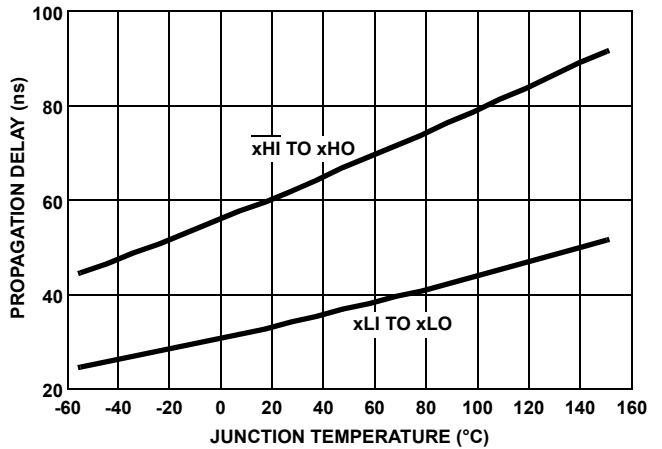

FIGURE 16. PROPAGATION DELAY

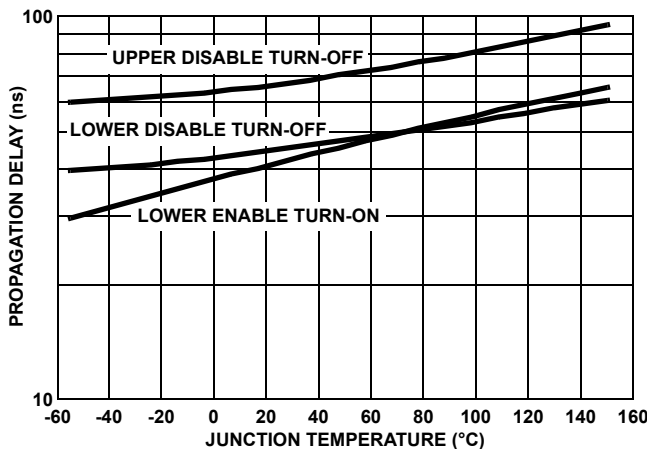

FIGURE 17. DISABLE PIN PROPAGATION DELAY

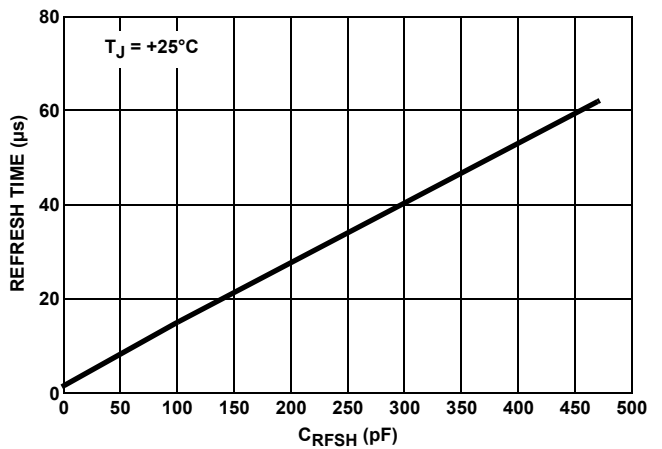

FIGURE 18. REFRESH TIME

## Typical Performance Curves (Continued)

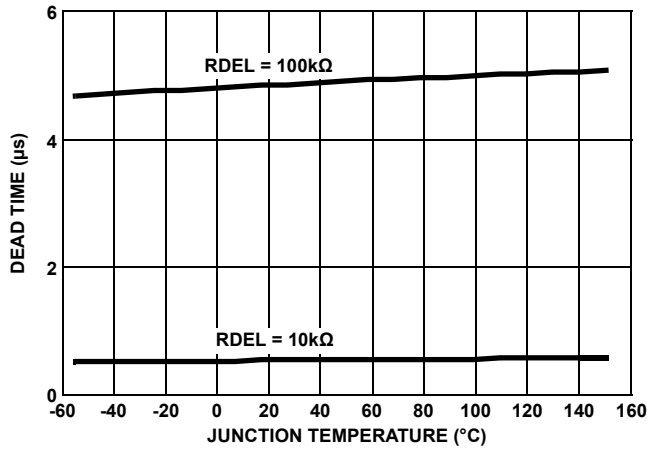

FIGURE 19. DEAD TIME

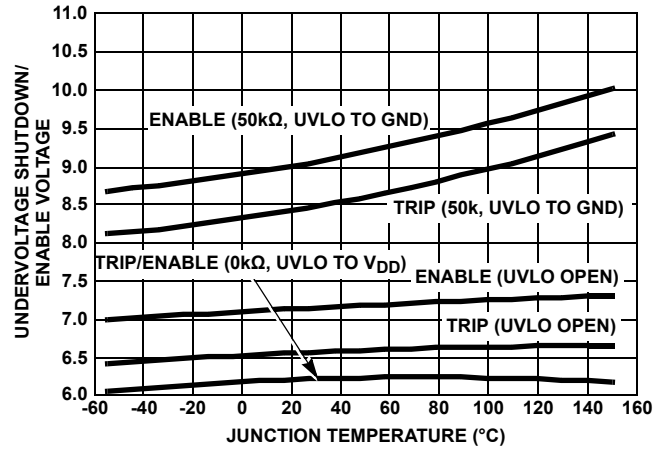

FIGURE 20. UNDERVOLTAGE THRESHOLD

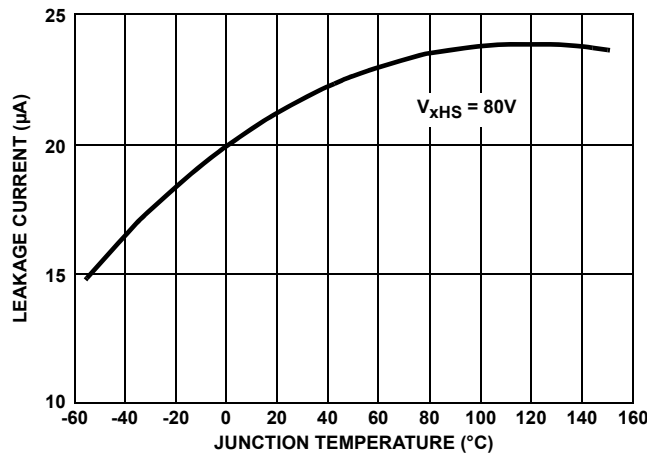

FIGURE 21. I<sub>xHS</sub> LEAKAGE CURRENT

## Functional Description

### Input Logic

NOTE: When appropriate for brevity, input and output pins will be prefixed with an “x” as a substitute for A, B, or C. For example, xHS refers to pins AHS, BHS, and CHS.

The HIP4086/A are 3-phase bridge drivers designed specifically for motor drive applications. Three identical half bridge sections, A, B and C, can be controlled individually by their input pins, ALI, AHI, BLI, BHI, and CLI, CHI (xLI, xHI) or the 2 corresponding input pins for each section can be tied together to form a PWM input (xLI connected to xHI = xPWM). When controlling individual inputs, the programmable dead time is optional but shoot-through protection must then be incorporated in the timing of the input signals. If the PWM mode is chosen, then the internal programmable dead time must be used.

### Shoot-Through Protection

Dead time, to prevent shoot-through, is implemented by delaying the turn-on of the high-side and low-side drivers. The delay timers

are enabled if the voltage on the RDEL pin is greater than 100mV. The voltage on RDEL will be greater than 100mV for any value of programming resistor in the specified range. If the voltage on RDEL is less than 100mV, the delay timers are disabled and no shoot-through protection is provided by the internal logic of the HIP4086/A. When the dead time is to be disabled, RDEL should be shorted to VSS.

### Refresh Pulse

To insure that the boot capacitors are charged prior to turning on the high-side drivers, a refresh pulse is triggered when DIS is low or when the UV comparator transitions low ( $V_{DD}$  is greater than the programmed undervoltage threshold). Please refer to the [“Block Diagram” on page 2](#). When triggered, the refresh pulse turns on all of the low-side drivers ( $xLO = 1$ ) and turns off all of the high-side drivers ( $xHO = 0$ ) for a duration set by a resistor tied between RDEL and VSS. When  $xLO = 1$ , the low-side bridge FETs charge the boot capacitors from VDD through the boot diodes.

# HIP4086, HIP4086A

## Charge Pump

The internal charge pump of the HIP4086/A is used to maintain the bias on the boot capacitor for 100% duty cycle. There is no limit for the duration of this period. The user must understand that this charge pump is only intended to provide the static bias current of the high-side drivers and the gate leakage current of the high-side bridge FETs. It cannot provide in a reasonable time, the majority of the charge on the boot capacitor that is consumed, when the xHO drivers source the gate charge to turn on the high-side bridge FETs. The boot capacitors should be sized so that they do not discharge excessively when sourcing the gate charge. See ["Application Information"](#) for methods to size the boot capacitors.

The charge pump has sufficient capacity to source a worst-case minimum of 40µA to the external load. The gate leakage current of most power MOSFETs is about 100nA so there is more than sufficient current to maintain the charge on the boot capacitors. Because the charge pump current is small, a gate-to-source resistor on the high-side bridge FETs is not recommended. When calculating the leakage load on the outputs of xHS, also include the leakage current of the boot capacitor. This is rarely a problem but it could be an issue with electrolytic capacitors at high temperatures.

## Application Information

### Selecting the Boot Capacitor Value

The boot capacitor value is chosen not only to supply the internal bias current of the high-side driver but also, and more significantly, to provide the gate charge of the driven FET without causing the boot voltage to sag excessively. In practice, the boot capacitor should have a total charge that is about 20 times the gate charge of the driven power FET for approximately a 5% drop in voltage after charge has been transferred from the boot capacitor to the gate capacitance.

The following parameters shown in [Table 2](#) are required to calculate the value of the boot capacitor for a specific amount of voltage droop when using the HIP4086/A (no charge pump). In [Table 2](#), the values used are arbitrary. They should be changed to comply with the actual application.

TABLE 2.

$V_{DD} = 10V$	$V_{DD}$ can be any value between 7 and 15VDC.
$V_{HB} = V_{DD} - 0.6V = V_{HO}$	High-side driver bias voltage ( $V_{DD}$ - boot diode voltage) referenced to $V_{HS}$ .
Period = 1ms	This is the longest expected switching period.
$I_{HB} = 100\mu A$	Worst case high-side driver current when xHO = high (this value is specified for $V_{DD} = 12V$ but the error is not significant).
$R_{GS} = 100k\Omega$	Gate-to-source resistor (usually not needed).
Ripple = 5%	Desired ripple voltage on the boot capacitor (larger ripple is not recommended).
$I_{gate\_leak} = 100nA$	From the FET vendor's datasheet.
$Q_{gate80V} = 64nC$	From <a href="#">Figure 22</a> .

[Equation 1](#) calculates the total charge required for the Period duration. This equation assumes that all of the parameters are constant during the Period duration. The error is insignificant if Ripple is small.

$$Q_C = Q_{gate80V} + \text{Period} \times (I_{HB} + V_{HO}/R_{GS} + I_{gate\_leak})$$

$$C_{boot} = Q_C / (\text{Ripple} \times V_{DD})$$

$$C_{boot} = 0.52\mu F \quad (\text{EQ. 1})$$

If the gate-to-source resistor is removed ( $R_{GS}$  is usually not needed or recommended), then:

$$C_{boot} = 0.33\mu F$$

These values of  $C_{boot}$  will sustain the high-side driver bias during Period with only a small amount of Ripple. But in the case of the HIP4086, the charge pump reduces the value of  $C_{boot}$  even more. The specified charge pump current is a minimum of 40µA, which is more than sufficient to source  $I_{gate\_leak}$ . Also, because the specified charge pump current is in excess of what is needed for  $I_{HB}$ , the total charge required to be sourced by the boot capacitor is shown by [Equation 2](#).

$$Q_C = Q_{gate80V} \text{ or } C_{boot} = 0.13\mu F \quad (\text{EQ. 2})$$

Not only is the required boot capacitor smaller in value, there is no restriction on the duration of Period.

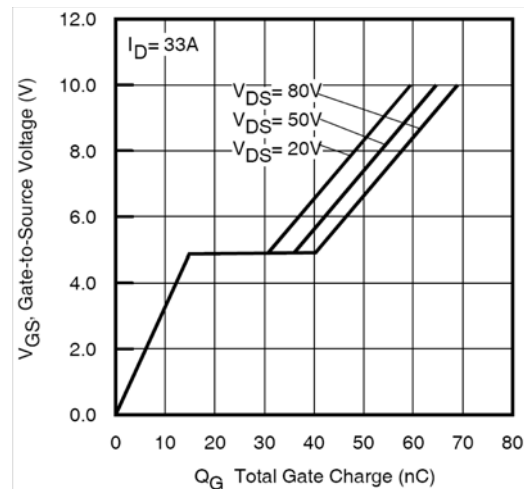

FIGURE 22. TYPICAL GATE VOLTAGE vs GATE CHARGE

## Typical Application Circuit

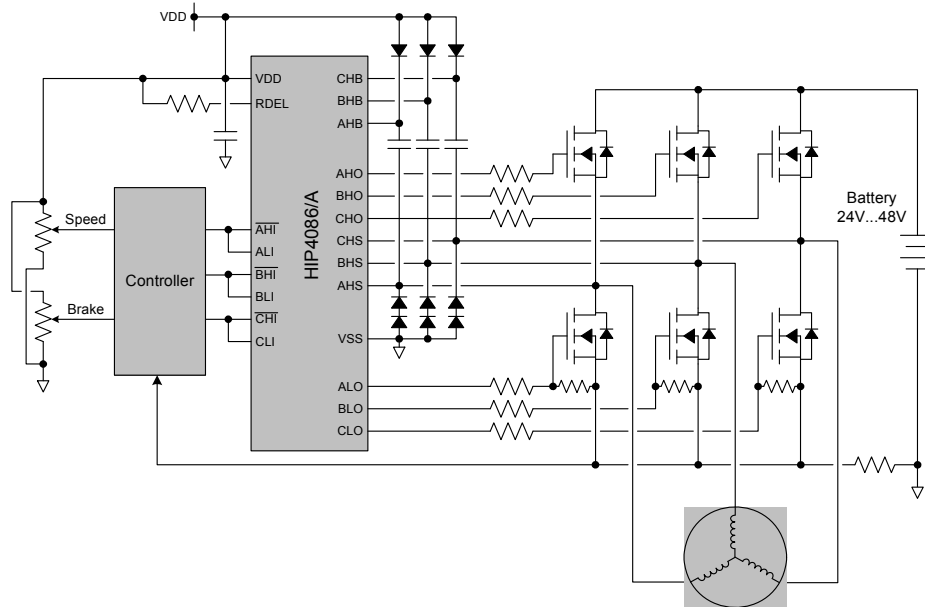

FIGURE 23. TYPICAL APPLICATION CIRCUIT

Figure 23 is an example of how the HIP4086 and HIP4086A 3-phase drivers can be applied to drive a 3-phase motor.

Depending on the application, the switching speed of the bridge FETs can be reduced by adding series connected resistors between the xHO outputs and the FET gates. Gate-to-source resistors are recommended on the low-side FETs to prevent unexpected turn-on of the bridge should the bridge voltage be applied before  $V_{DD}$ . Gate-to-source resistors on the high-side FETs are not usually required if low-side gate-to-source resistors are used. If relatively small gate-to-source resistors are used on the high-side FETs, be aware that they will load the charge pump of the HIP4086 negating the ability of the charge pump to keep the high-side driver biased during very long periods.

An important operating condition that is frequently overlooked by designers is the negative transient on the xHS pins that occurs when the high-side bridge FET turns off. The absolute maximum transient allowed on the xHS pin is -6V but it is wise to minimize the amplitude to lower levels. This transient is the result of the parasitic inductance of the low-side drain-to-source conductor on the PCB. Even the parasitic inductance of the low-side FET contributes to this transient.

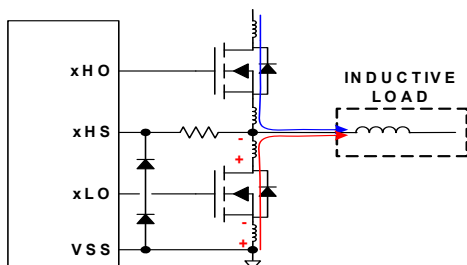

FIGURE 24. BRIDGE WITH PARASITIC INDUCTANCES

When the high-side bridge FET turns off, because of the inductive characteristics of a motor load, the current that was flowing in

the high-side FET (blue) must rapidly commutate to flow through the low-side FET (red). The amplitude of the negative transient impressed on the xHS node is  $(di/dt \times L)$  where L is the total parasitic inductance of the low-side FET drain-to-source path and  $di/dt$  is the rate at which the high-side FET is turned off. With the increasing power levels of new generation motor drives, clamping this transient becomes more and more significant for the proper operation of the HIP4086/A.

There are several ways of reducing the amplitude of this transient. If the bridge FETs are turned off more slowly to reduce  $di/dt$ , the amplitude will be reduced but at the expense of more switching losses in the FETs. Careful PCB design will also reduce the value of the parasitic inductance. However, these two solutions by themselves may not be sufficient. Figure 24 illustrates a simple method for clamping the negative transient. Two series connected, fast PN junction, 1A diodes are connected between xHS and VSS as shown. It is important that the components be placed as close as possible to the xHS and VSS pins to minimize the parasitic inductance of this current path. Two series connected diodes are required because they are in parallel with the body diode of the low-side FET. If only one diode is used for the clamp, it will conduct some of the negative load current that is flowing in the low-side FET. In severe cases, a small value resistor in series with the xHS pin as shown, will further reduce the amplitude of the negative transient.

Please note that a similar transient with a positive polarity occurs when the low-side FET turns off. This is less frequently a problem because xHS node is floating up toward the bridge bias voltage. The absolute maximum voltage rating for the xHS node does need to be observed when the positive transient occurs.

## General PCB Layout Guidelines

The AC performance of the HIP4086/A depends significantly on the design of the PC board. The following layout design guidelines are recommended to achieve optimum performance:

- Place the driver as close as possible to the driven power FETs.
- Understand where the switching power currents flow. The high amplitude di/dt currents of the driven power FET will induce significant voltage transients on the associated traces.
- Keep power loops as short as possible by paralleling the source and return traces.
- Use planes where practical; they are usually more effective than parallel traces.
- Avoid paralleling high amplitude di/dt traces with low level signal lines. High di/dt will induce currents and consequently, noise voltages in the low level signal lines.
- When practical, minimize impedances in low level signal circuits. The noise, magnetically induced on a 10k $\Omega$  resistor, is 10x larger than the noise on a 1k $\Omega$  resistor.
- Be aware of magnetic fields emanating from motors, transformers and inductors. Gaps in these magnetic structures are especially bad for emitting flux.
- If you must have traces close to magnetic devices, align the traces so that they are parallel to the flux lines to minimize coupling.
- The use of low inductance components such as chip resistors and chip capacitors is highly recommended.
- Use decoupling capacitors to reduce the influence of parasitic inductance in the VDD and GND leads. To be effective, these capacitors must also have the shortest possible conduction paths. If vias are used, connect several paralleled vias to reduce the inductance of the vias.
- It may be necessary to add resistance to dampen resonating parasitic circuits especially on xHO and xLO. If an external gate resistor is unacceptable, then the layout must be improved to minimize lead inductance.
- Keep high dv/dt nodes away from low level circuits. Guard banding can be used to shunt away dv/dt injected currents from sensitive circuits. This is especially true for control circuits that source the input signals to the HIP4086/A.
- Avoid having a signal ground plane under a high amplitude dv/dt circuit. This will inject di/dt currents into the signal ground paths.
- Do power dissipation and voltage drop calculations of the power traces. Many PCB/CAD programs have built in tools for calculation of trace resistance.
- Large power components (power FETs, electrolytic capacitors, power resistors, etc.) will have internal parasitic inductance which cannot be eliminated. This must be accounted for in the PCB layout and circuit design.
- If you simulate your circuits, consider including parasitic components especially parasitic lead inductance.

# HIP4086, HIP4086A

## Revision History

The revision history provided is for informational purposes only and is believed to be accurate, however, not warranted. Please go to the web to make sure that you have the latest revision.

DATE	REVISION	CHANGE
January 12, 2017	FN4220.11	<p>The following revisions were made to the DC and AC Electrical Specifications:</p> <ul style="list-style-type: none"> <li>-VDD Quiescent Current (HIP4086): updated maximum (<math>T_J = +25^\circ\text{C}</math>) from "4.2" to "5.1", updated min and max (<math>T_J = -40^\circ\text{C}</math> to <math>+150^\circ\text{C}</math>) from "2.1" to "1.96" and "4.3" to "5.3", respectively.</li> <li>-VDD Quiescent Current (HIP4086A): updated max and typical (<math>T_J = +25^\circ\text{C}</math>) from "2.6" to "3.1" and from "2.4" to "2.8", updated min and max (<math>T_J = -40^\circ\text{C}</math> to <math>+150^\circ\text{C}</math>) from "2.1" to "1.8" and from "2.7" to "3.3", respectively.</li> <li>-VDD Operating Current (HIP4086): updated min and max (<math>T_J = +25^\circ\text{C}</math>) from "6.3" to "5.4" and from "10.5" to "13", updated min and max (<math>T_J = -40^\circ\text{C}</math> to <math>+150^\circ\text{C}</math>) from "5" to "4" and "11" to "13.5", respectively.</li> <li>-VDD Operating Current (HIP4086A): updated typical and max (<math>T_J = +25^\circ\text{C}</math>) from "3.6" to "4.0" and from "4.1" to "4.6", updated min and max (<math>T_J = -40^\circ\text{C}</math> to <math>+150^\circ\text{C}</math>) from "2.8" to "2.7" and from "4.4" to "5.1", respectively.</li> <li>-xHB On Quiescent Current (HIP4086): updated maximum (<math>T_J = +25^\circ\text{C}</math>) from "80" to "110", updated maximum (<math>T_J = -40^\circ\text{C}</math> to <math>+150^\circ\text{C}</math>) from "100" to "140".</li> <li>-xHB On Quiescent Current (HIP4086A): updated typical and max (<math>T_J = +25^\circ\text{C}</math>) from "80" to "90" and from "100" to "115", updated maximum (<math>T_J = -40^\circ\text{C}</math> to <math>+150^\circ\text{C}</math>) from "200" to "225".</li> <li>-xHB Off Quiescent Current (HIP4086A): updated typical and max (<math>T_J = +25^\circ\text{C}</math>) from "0.9" to "1.0" and from "1" to "1.2", updated maximum (<math>T_J = -40^\circ\text{C}</math> to <math>+150^\circ\text{C}</math>) from "1.2" to "1.25".</li> <li>-xHB Operating Current (HIP4086A): updated maximum (<math>T_J = +25^\circ\text{C}</math>) from "1" to "1.1", updated maximum (<math>T_J = -40^\circ\text{C}</math> to <math>+150^\circ\text{C}</math>) from "1.2" to "1.25".</li> <li>-xHB, xHS Leakage Current: updated typical (<math>T_J = +25^\circ\text{C}</math>) from "24" to "30".</li> <li>-Minimum Undervoltage Threshold: updated min (<math>T_J = -40^\circ\text{C}</math> to <math>+150^\circ\text{C}</math>) from "4.9" to "4.8".</li> <li>-QPUMP Output Voltage: updated min and max (<math>T_J = +25^\circ\text{C}</math>) from "11.5" to "11" and from "14" to "14.6", updated min and max (<math>T_J = -40^\circ\text{C}</math> to <math>+150^\circ\text{C}</math>) from "10.5" to "10" and "14.5" to "14.75", respectively.</li> <li>-QPUMP Output Current: updated min and max (<math>T_J = +25^\circ\text{C}</math>) from "50" to "40" and from "130" to "160", updated maximum (<math>T_J = -40^\circ\text{C}</math> to <math>+150^\circ\text{C}</math>) from "140" to "185".</li> <li>-Low Level Input Current: updated maximum (<math>T_J = +25^\circ\text{C}</math>) from "-135" to "-155", updated maximum (<math>T_J = -40^\circ\text{C}</math> to <math>+150^\circ\text{C}</math>) from "-140" to "-165".</li> <li>-Low Level Output Voltage: updated maximum (<math>T_J = -40^\circ\text{C}</math> to <math>+150^\circ\text{C}</math>) from "200" to "210".</li> <li>-Dead Time (RDEL = 100k<math>\Omega</math>): updated min and max (<math>T_J = +25^\circ\text{C}</math>) from "3.8" to "3" and from "6" to "7.2", updated maximum (<math>T_J = -40^\circ\text{C}</math> to <math>+150^\circ\text{C}</math>) from "7" to "8".</li> <li>-Dead Time (RDEL = 10k<math>\Omega</math>): updated maximum (<math>T_J = +25^\circ\text{C}</math>) from "0.65" to "0.75", updated maximum (<math>T_J = -40^\circ\text{C}</math> to <math>+150^\circ\text{C}</math>) from "0.7" to "0.8".</li> <li>-xLI to xLO turn-off: updated maximum (<math>T_J = +25^\circ\text{C}</math>) from "45" to "55", updated maximum (<math>T_J = -40^\circ\text{C}</math> to <math>+150^\circ\text{C}</math>) from "65" to "75".</li> <li>-xHI to xHO turn-off: updated maximum (<math>T_J = +25^\circ\text{C}</math>) from "90" to "110", updated maximum (<math>T_J = -40^\circ\text{C}</math> to <math>+150^\circ\text{C}</math>) from "100" to "135".</li> <li>-xLI to xLO turn-on: updated maximum (<math>T_J = +25^\circ\text{C}</math>) from "75" to "82", updated maximum (<math>T_J = -40^\circ\text{C}</math> to <math>+150^\circ\text{C}</math>) from "90" to "100".</li> <li>-xHI to xHO turn-on: updated maximum (<math>T_J = +25^\circ\text{C}</math>) from "90" to "110", updated maximum (<math>T_J = -40^\circ\text{C}</math> to <math>+150^\circ\text{C}</math>) from "100" to "158".</li> <li>-Rise Time: updated maximum (<math>T_J = -40^\circ\text{C}</math> to <math>+150^\circ\text{C}</math>) from "50" to "60".</li> <li>-Fall Time: updated maximum (<math>T_J = -40^\circ\text{C}</math> to <math>+150^\circ\text{C}</math>) from "25" to "40".</li> <li>-DIS to xLO turn-off: updated maximum (<math>T_J = -40^\circ\text{C}</math> to <math>+150^\circ\text{C}</math>) from "90" to "104".</li> <li>-DIS to xHO turn-off: updated maximum (<math>T_J = +25^\circ\text{C}</math>) from "90" to "116", updated maximum (<math>T_J = -40^\circ\text{C}</math> to <math>+150^\circ\text{C}</math>) from "100" to "147".</li> <li>-DIS to xLO turn-on: updated maximum (<math>T_J = +25^\circ\text{C}</math>) from "80" to "85", updated maximum (<math>T_J = -40^\circ\text{C}</math> to <math>+150^\circ\text{C}</math>) from "100" to "120".</li> </ul> <p>Minor Parameter label changes to use consistent descriptions for related parameters. Updated from "50<math>\mu\text{A}</math>" to "40<math>\mu\text{A}</math>" in "Charge Pump" and "Selecting the Boot Capacitor Value" on page 11.</p>
March 27, 2015	FN4220.10	<p>Added AN1829, "HIP4086 3-Phase BLDC Motor Drive Demonstration Board, User Guide" bullet to the related literature section on page 1.</p> <p>On page 3:</p> <ul style="list-style-type: none"> <li>In the Pin Configuration updated typo for Pin 17 Pin Name from "AHC" to "AHO".</li> <li>In the Pin Description table: <ul style="list-style-type: none"> <li>Updated RDEL and UVLO Description to reference the correct Figures.</li> <li>RDEL - from "Figure 18" to "Figure 19" and UVLO - from "Figure 19" to "Figure 20".</li> <li>Updated typo-AHS pin number from "15" to "18".</li> </ul> </li> </ul> <p>Added "RDEL range 10k<math>\Omega</math> to 100k<math>\Omega</math>" to the "Maximum Recommended Operating Conditions" on page 5. Updated the About Intersil verbiage.</p>
January 28, 2013	FN4220.9	<p>Corrected following typo in the second paragraph of page 1:</p> <p>From: (0.5ms to 4.5ms) To: (0.5<math>\mu\text{s}</math> to 4.5<math>\mu\text{s}</math>)</p>

# HIP4086, HIP4086A

**Revision History** The revision history provided is for informational purposes only and is believed to be accurate, however, not warranted. Please go to the web to make sure that you have the latest revision. (Continued)

DATE	REVISION	CHANGE
September 27, 2012	FN4220.8	Removed evaluation board from "Ordering Information" and "Related Literature" since it is inactive.
June 1, 2011	FN4220.7	Added alternate parameters for HIP4086A in DC Electrical Specifications Table Supply Currents on page 5. Added to Charge Pump Figures 11 and 12 in Typical Performance Curves "HIP4086 Only" -Converted to new Intersil datasheet template. -Changed Title from "80V, 500mA, 3-Phase Driver" to "80V, 500mA, 3-Phase MOSFET Driver". -Rewrote description on page 1 by adding HIP4086A and stating the differences between parts. -Updated "Ordering Information" on page 4 by adding part number HIP4086AABZ and Eval Board. Added MSL note. Removed obsolete part HIP4086AP. -Updated "TYPICAL APPLICATION" on page 1. -Added Figure 2 on page 1. -Updated "Features" and "Applications" section on page 1. -Added "" on page 1. -Updated "Block Diagram" on page 2 by adding color and notes. -Updated "Thermal Information" and notes on page 5. -Added "Boldface limits apply.." to common conditions of Electrical Specifications tables. Added Note 9 to MIN and MAX columns of Electrical Specifications tables. -Updated all timing diagrams for better clarification on page 7. -Added "Functional Description", "Application Information" and "General PCB Layout Guidelines" sections beginning on page 10. -Updated Package Outline Drawing M24.3 by removing table listing dimensions and putting dimensions on drawing. Added Land Pattern. -Added "Revision History" and "About Intersil" to page 15.
July 26, 2004	FN4220.6	Added Pb-Free parts to "Ordering Information" on page 4.
February 18, 2003	FN4220.5	Revised "Pin Descriptions" on page 3. Revised "Low Level Input Current" specs on page 6.
May, 1999	FN4220.4	Initial Release.

## About Intersil

Intersil Corporation is a leading provider of innovative power management and precision analog solutions. The company's products address some of the largest markets within the industrial and infrastructure, mobile computing and high-end consumer markets.

For the most updated datasheet, application notes, related documentation and related parts, please see the respective product information page found at [www.intersil.com](http://www.intersil.com).

For a listing of definitions and abbreviations of common terms used in our documents, visit: [www.intersil.com/glossary](http://www.intersil.com/glossary).

You may report errors or suggestions for improving this datasheet by visiting [www.intersil.com/ask](http://www.intersil.com/ask).

Reliability reports are also available from our website at [www.intersil.com/support](http://www.intersil.com/support).

For additional products, see [www.intersil.com/en/products.html](http://www.intersil.com/en/products.html)

Intersil products are manufactured, assembled and tested utilizing ISO9001 quality systems as noted in the quality certifications found at [www.intersil.com/en/support/qualandreliability.html](http://www.intersil.com/en/support/qualandreliability.html)

*Intersil products are sold by description only. Intersil may modify the circuit design and/or specifications of products at any time without notice, provided that such modification does not, in Intersil's sole judgment, affect the form, fit or function of the product. Accordingly, the reader is cautioned to verify that datasheets are current before placing orders. Information furnished by Intersil is believed to be accurate and reliable. However, no responsibility is assumed by Intersil or its subsidiaries for its use; nor for any infringements of patents or other rights of third parties which may result from its use. No license is granted by implication or otherwise under any patent or patent rights of Intersil or its subsidiaries.*

For information regarding Intersil Corporation and its products, see [www.intersil.com](http://www.intersil.com)

# HIP4086, HIP4086A

## Package Outline Drawing

For the most recent package outline drawing, see [M24.3](#).

### M24.3

24 LEAD WIDE BODY SMALL OUTLINE PLASTIC PACKAGE (SOIC)

Rev 2, 3/11

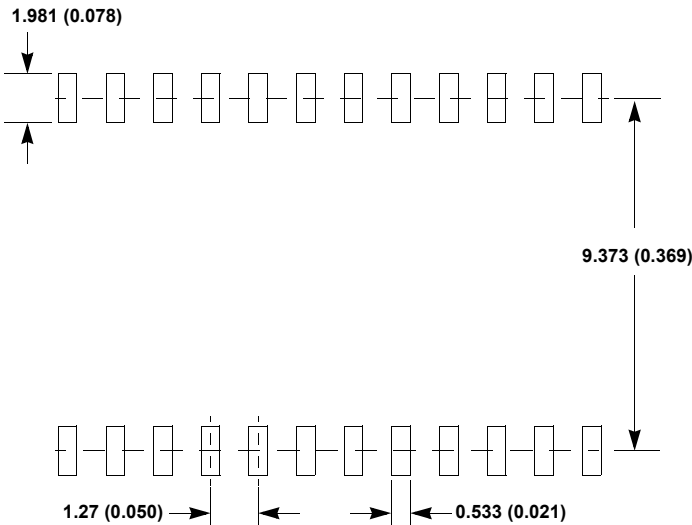
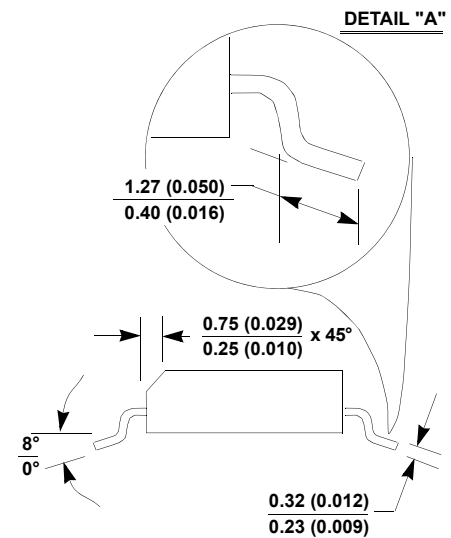
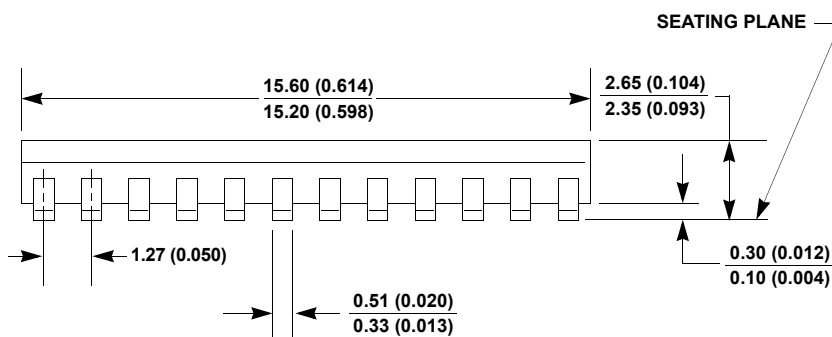
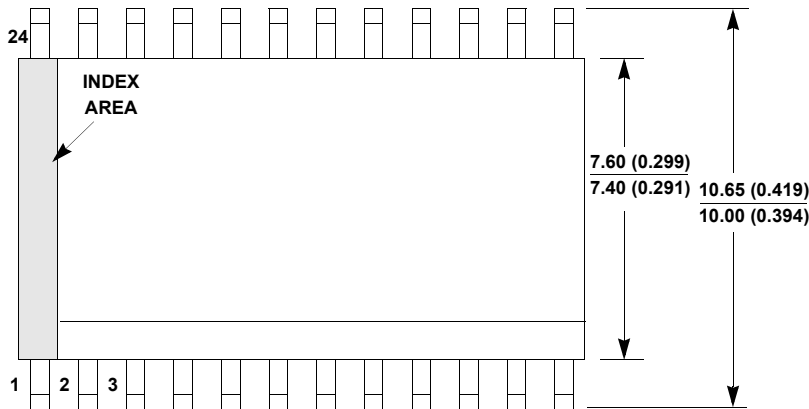

#### NOTES:

1. Dimensioning and tolerancing per ANSI Y14.5M-1982.
2. Package length does not include mold flash, protrusions or gate burrs. Mold flash, protrusion and gate burrs shall not exceed 0.15mm (0.006 inch) per side.
3. Package width does not include interlead flash or protrusions. Interlead flash and protrusions shall not exceed 0.25mm (0.010 inch) per side.
4. The chamfer on the body is optional. If it is not present, a visual index feature must be located within the crosshatched area.
5. Terminal numbers are shown for reference only.
6. The lead width as measured 0.36mm (0.014 inch) or greater above the seating plane, shall not exceed a maximum value of 0.61mm (0.024 inch).
7. Controlling dimension: MILLIMETER. Converted inch dimensions in ( ) are not necessarily exact.
8. This outline conforms to JEDEC publication MS-013-AD ISSUE C.

# HIP4086, HIP4086A

## Dual-In-Line Plastic Packages (PDIP)

For the most recent package outline drawing, see [E24.3](#).

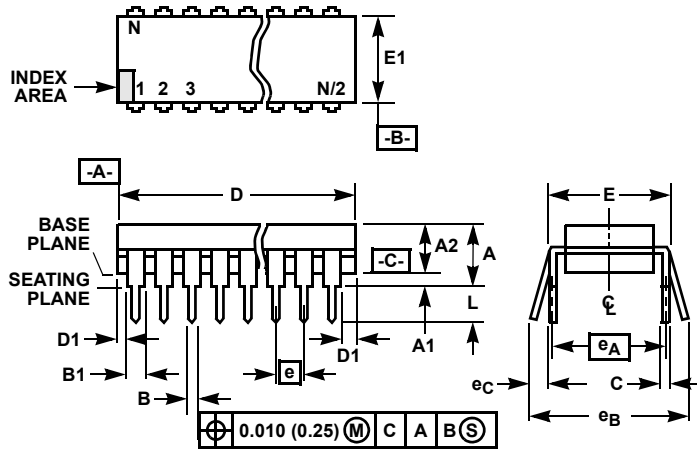

### NOTES:

- Controlling Dimensions: INCH. In case of conflict between English and Metric dimensions, the inch dimensions control.
- Dimensioning and tolerancing per ANSI Y14.5M-1982.
- Symbols are defined in the "MO Series Symbol List" in Section 2.2 of Publication No. 95.
- Dimensions A, A1 and L are measured with the package seated in JEDEC seating plane gauge GS-3.
- D, D1, and E1 dimensions do not include mold flash or protrusions. Mold flash or protrusions shall not exceed 0.010 inch (0.25mm).
- E and  $e_A$  are measured with the leads constrained to be perpendicular to datum -C-.
- $e_B$  and  $e_C$  are measured at the lead tips with the leads unconstrained.  $e_C$  must be zero or greater.
- B1 maximum dimensions do not include dambar protrusions. Dambar protrusions shall not exceed 0.010 inch (0.25mm).
- N is the maximum number of terminal positions.
- Corner leads (1, N, N/2 and N/2 + 1) for E8.3, E16.3, E18.3, E28.3, E42.6 will have a B1 dimension of 0.030 - 0.045 inch (0.76 - 1.14mm).

### E24.3 (JEDEC MS-001-AF ISSUE D)

#### 24 LEAD NARROW BODY DUAL-IN-LINE PLASTIC PACKAGE

SYMBOL	INCHES		MILLIMETERS		NOTES
	MIN	MAX	MIN	MAX	
A	-	0.210	-	5.33	4
A1	0.015	-	0.39	-	4
A2	0.115	0.195	2.93	4.95	-
B	0.014	0.022	0.356	0.558	-
B1	0.045	0.070	1.15	1.77	8
C	0.008	0.014	0.204	0.355	-
D	1.230	1.280	31.24	32.51	5
D1	0.005	-	0.13	-	5
E	0.300	0.325	7.62	8.25	6
E1	0.240	0.280	6.10	7.11	5
e	0.100 BSC		2.54 BSC		-
$e_A$	0.300 BSC		7.62 BSC		6
$e_B$	-	0.430	-	10.92	7
L	0.115	0.150	2.93	3.81	4
N	24		24		9

Rev. 0 12/93