



Chipsmall Limited consists of a professional team with an average of over 10 year of expertise in the distribution of electronic components. Based in Hongkong, we have already established firm and mutual-benefit business relationships with customers from,Europe,America and south Asia,supplying obsolete and hard-to-find components to meet their specific needs.

With the principle of “Quality Parts,Customers Priority,Honest Operation,and Considerate Service”,our business mainly focus on the distribution of electronic components. Line cards we deal with include Microchip,ALPS,ROHM,Xilinx,Pulse,ON,Everlight and Freescale. Main products comprise IC,Modules,Potentiometer,IC Socket,Relay,Connector.Our parts cover such applications as commercial,industrial, and automotives areas.

We are looking forward to setting up business relationship with you and hope to provide you with the best service and solution. Let us make a better world for our industry!



## Contact us

Tel: +86-755-8981 8866 Fax: +86-755-8427 6832

Email & Skype: info@chipsmall.com Web: www.chipsmall.com

Address: A1208, Overseas Decoration Building, #122 Zhenhua RD., Futian, Shenzhen, China



**NOT RECOMMENDED FOR NEW DESIGNS  
NO RECOMMENDED REPLACEMENT  
contact our Technical Support Center at  
1-888-INTERSIL or www.intersil.com/tsc**

## Buck Pulse-Width Modulator (PWM) Controller

The HIP6013 provides complete control and protection for a DC-DC converter optimized for high-performance microprocessor applications. It is designed to drive an N-Channel MOSFET in a standard buck topology. The HIP6013 integrates all of the control, output adjustment, monitoring and protection functions into a single package.

The output voltage of the converter can be precisely regulated to as low as 1.27V, with a maximum tolerance of ±1.5% over temperature and line voltage variations.

The HIP6013 provides simple, single feedback loop, voltage-mode control with fast transient response. It includes a 200kHz free-running triangle-wave oscillator that is adjustable from below 50kHz to over 1MHz. The error amplifier features a 15MHz gain-bandwidth product and 6V/μs slew rate which enables high converter bandwidth for fast transient performance. The resulting PWM duty ratio ranges from 0% to 100%.

The HIP6013 protects against over-current conditions by inhibiting PWM operation. The HIP6013 monitors the current by using the  $r_{DS(ON)}$  of the upper MOSFET which eliminates the need for a current sensing resistor.

## Ordering Information

PART NUMBER	PART MARKING	TEMP. RANGE (°C)	PACKAGE	PKG. DWG. #
HIP6013CB	HIP6013CB	0 to 70	14 Ld SOIC	M14.15
HIP6013CBZ (See Note)	6013CBZ	0 to 70	14 Ld SOIC (Pb-free)	M14.15

Add "-T" suffix for tape and reel.

NOTE: Intersil Pb-free plus anneal products employ special Pb-free material sets; molding compounds/die attach materials and 100% matte tin plate termination finish, which are RoHS compliant and compatible with both SnPb and Pb-free soldering operations. Intersil Pb-free products are MSL classified at Pb-free peak reflow temperatures that meet or exceed the Pb-free requirements of IPC/JEDEC J STD-020.

## Features

- Drives N-Channel MOSFET
- Operates From +5V or +12V Input
- Simple Single-Loop Control Design
  - Voltage-Mode PWM Control
- Fast Transient Response
  - High-Bandwidth Error Amplifier
  - Full 0% to 100% Duty Ratio
- Excellent Output Voltage Regulation
  - 1.27V Internal Reference
  - ±1.5% Over Line Voltage and Temperature
- Over-Current Fault Monitor
  - Does Not Require Extra Current Sensing Element
  - Uses MOSFET's  $r_{DS(on)}$
- Small Converter Size
  - Constant Frequency Operation
  - 200kHz Free-Running Oscillator Programmable from 50kHz to Over 1MHz
- 14 Ld, SOIC Package
- Pb-Free Plus Anneal Available (RoHS Compliant)

## Applications

- Power Supply for Pentium®, Pentium Pro, PowerPC™ and Alpha™ Microprocessors
- High-Power 5V to 3.xV DC-DC Regulators
- Low-Voltage Distributed Power Supplies

## Pinout

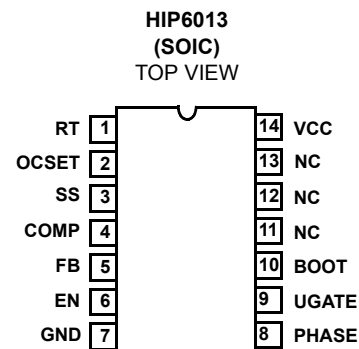

PowerPC™ is a trademark of IBM.  
Alpha™ is a trademark of Digital Equipment Corporation.  
Pentium® is a registered trademark of Intel Corporation.

Typical Application

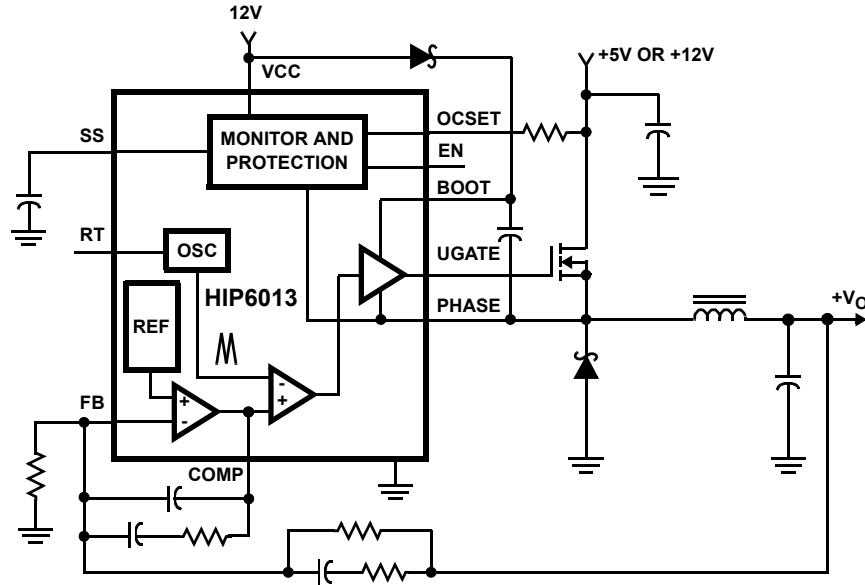

Block Diagram

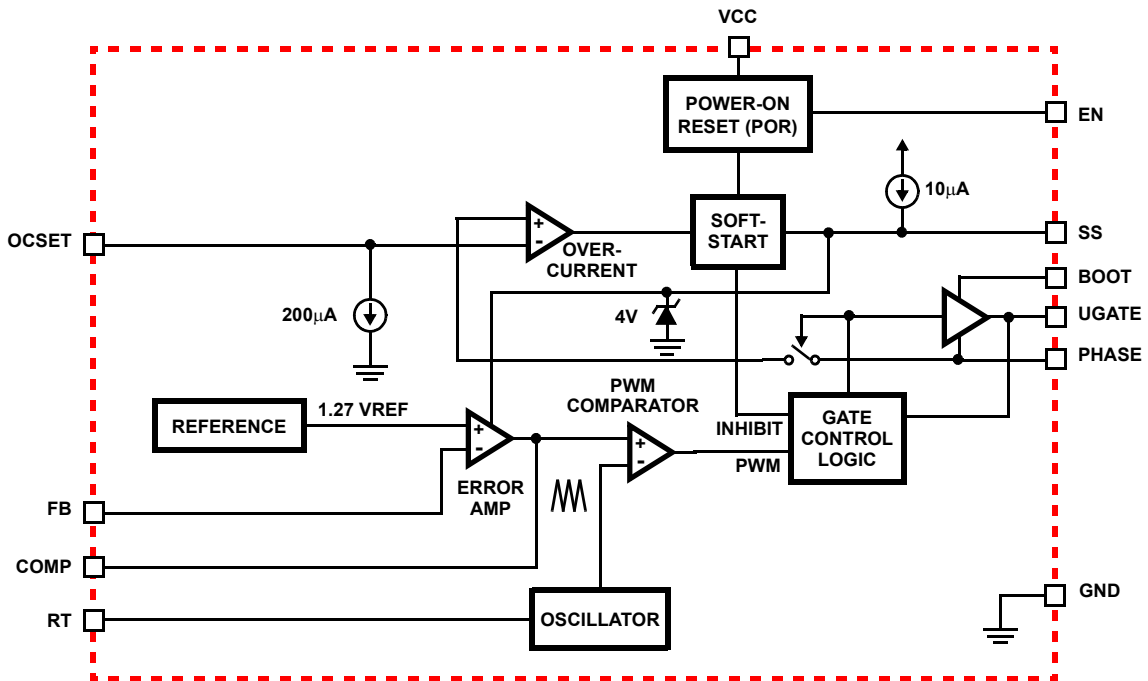

**Absolute Maximum Ratings**

Supply Voltage, V<sub>CC</sub> ..... +15.0V  
 Boot Voltage, V<sub>BOOT</sub> - V<sub>PHASE</sub> ..... +15.0V  
 Input, Output or I/O Voltage ..... GND -0.3V to V<sub>CC</sub> +0.3V  
 ESD Classification ..... Class 2

**Operating Conditions**

Supply Voltage, V<sub>CC</sub> ..... +12V ±10%  
 Ambient Temperature Range ..... 0°C to 70°C  
 Junction Temperature Range ..... 0°C to 125°C

**Thermal Information**

Thermal Resistance (Typical, Note 1) ..... θ<sub>JA</sub> (°C/W)  
 SOIC Package ..... 185  
 Maximum Junction Temperature ..... 150°C  
 Maximum Storage Temperature Range ..... -65°C to 150°C  
 Maximum Lead Temperature (Soldering 10s) ..... 300°C  
 (SOIC - Lead Tips Only)

*CAUTION: Stresses above those listed in "Absolute Maximum Ratings" may cause permanent damage to the device. This is a stress only rating and operation of the device at these or any other conditions above those indicated in the operational sections of this specification is not implied.*

**NOTE:**

1. θ<sub>JA</sub> is measured with the component mounted on an evaluation PC board in free air.

Electrical Specifications Recommended Operating Conditions, Unless Otherwise Noted

PARAMETER	SYMBOL	TEST CONDITIONS	MIN	TYP	MAX	UNITS
<b>VCC SUPPLY CURRENT</b>						
Nominal Supply	I <sub>CC</sub>	EN = VCC; UGATE and LGATE Open	-	5	-	mA
Shutdown Supply		EN = 0V	-	50	100	µA
<b>POWER-ON RESET</b>						
Rising VCC Threshold		V <sub>OCSET</sub> = 4.5VDC	-	-	10.4	V
Falling VCC Threshold		V <sub>OCSET</sub> = 4.5VDC	8.8	-	-	V
Enable - Input threshold Voltage		V <sub>OCSET</sub> = 4.5VDC	0.8	-	2.0	V
Rising V <sub>OCSET</sub> Threshold			-	1.27	-	V
<b>OSCILLATOR</b>						
Free Running Frequency		RT = OPEN, V <sub>CC</sub> = 12	180	200	220	kHz
Total Variation		6kΩ < RT to GND < 200kΩ	-20	-	+20	%
Ramp Amplitude	ΔV <sub>OSC</sub>	RT = OPEN	-	1.9	-	V <sub>P-P</sub>
<b>REFERENCE</b>						
Reference Voltage			1.251	1.270	1.289	V
<b>ERROR AMPLIFIER</b>						
DC Gain			-	88	-	dB
Gain-Bandwidth Product	GBW		-	15	-	MHz
Slew Rate	SR	COMP = 10pF	-	6	-	V/µs
<b>GATE DRIVERS</b>						
Upper Gate Source	I <sub>UGATE</sub>	V <sub>BOOT</sub> - V <sub>PHASE</sub> = 12V, V <sub>UGATE</sub> = 6V	350	500	-	mA
Upper Gate Sink	R <sub>UGATE</sub>	I <sub>LGATE</sub> = 0.3A	-	5.5	10	Ω
<b>PROTECTION</b>						
OCSET Current Source	I <sub>OCSET</sub>	V <sub>OCSET</sub> = 4.5VDC	170	200	230	µA
Soft Start Current	I <sub>SS</sub>		-	10	-	µA

**Typical Performance Curves**

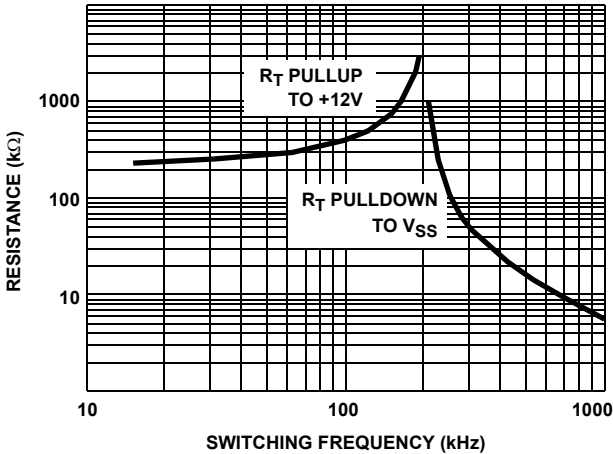

FIGURE 1.  $R_T$  RESISTANCE vs FREQUENCY

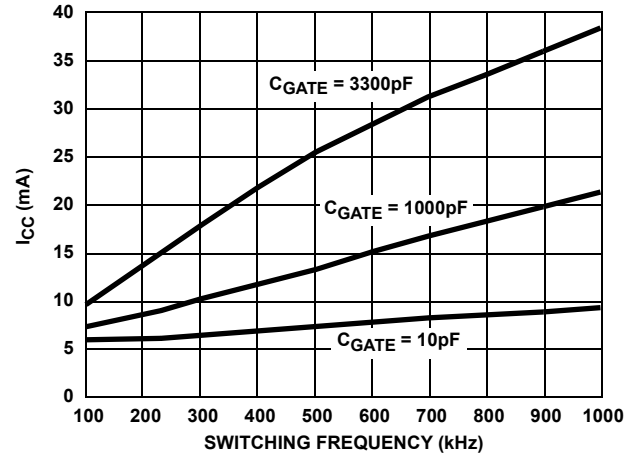
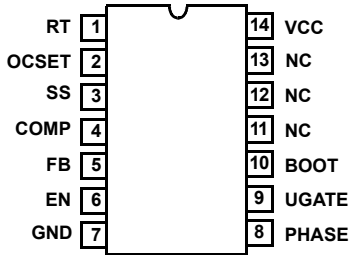

FIGURE 2. BIAS SUPPLY CURRENT vs FREQUENCY

**Functional Pin Description**



**RT (Pin 1)**

This pin provides oscillator switching frequency adjustment. By placing a resistor ( $R_T$ ) from this pin to GND, the nominal 200kHz switching frequency is increased according to the following equation:

$$F_s \approx 200\text{kHz} + \frac{5 \cdot 10^6}{R_T} \quad (R_T \text{ to GND})$$

Conversely, connecting a pull-up resistor ( $R_T$ ) from this pin to VCC reduces the switching frequency according to the following equation.:

$$F_s \approx 200\text{kHz} - \frac{4 \cdot 10^7}{R_T} \quad (R_T \text{ to } 12\text{V})$$

**OCSET (Pin 2)**

Connect a resistor ( $R_{OCSET}$ ) from this pin to the drain of the upper MOSFET.  $R_{OCSET}$ , an internal 200 $\mu$ A current source ( $I_{OCS}$ ), and the upper MOSFET on-resistance ( $r_{DS(ON)}$ ) set the converter over-current (OC) trip point according to the following equation:

$$I_{PEAK} = \frac{I_{OCS} \cdot R_{OCSET}}{r_{DS(ON)}}$$

An over-current trip cycles the soft-start function.

**SS (Pin 3)**

Connect a capacitor from this pin to ground. This capacitor, along with an internal 10 $\mu$ A current source, sets the soft-start interval of the converter.

**COMP (Pin 4) and FB (Pin 5)**

COMP and FB are the available external pins of the error amplifier. The FB pin is the inverting input of the error amplifier and the COMP pin is the error amplifier output. These pins are used to compensate the voltage-control feedback loop of the converter.

**EN (Pin 6)**

This pin is the open-collector enable pin. Pull this pin below 1V to disable the converter. In shutdown, the soft start pin is discharged and the UGATE and LGATE pins are held low.

**GND (Pin 7)**

Signal ground for the IC. All voltage levels are measured with respect to this pin.

**PHASE (Pin 8)**

Connect the PHASE pin to the upper MOSFET source. This pin is used to monitor the voltage drop across the MOSFET for over-current protection. This pin also provides the return path for the upper gate drive.

**UGATE (Pin 9)**

Connect UGATE to the upper MOSFET gate. This pin provides the gate drive for the upper MOSFET.

**BOOT (Pin 10)**

This pin provides bias voltage to the upper MOSFET driver. A bootstrap circuit may be used to create a BOOT voltage suitable to drive a standard N-Channel MOSFET.

**VCC (Pin 14)**

Provide a 12V bias supply for the chip to this pin.

## Functional Description

### Initialization

The HIP6013 automatically initializes upon receipt of power. Special sequencing of the input supplies is not necessary. The Power-On Reset (POR) function continually monitors the input supply voltages and the enable (EN) pin. The POR monitors the bias voltage at the VCC pin and the input voltage ( $V_{IN}$ ) on the OCSET pin. The level on OCSET is equal to  $V_{IN}$  less a fixed voltage drop (see over-current protection). With the EN pin held to VCC, the POR function initiates soft start operation after both input supply voltages exceed their POR thresholds. For operation with a single +12V power source,  $V_{IN}$  and  $V_{CC}$  are equivalent and the +12V power source must exceed the rising  $V_{CC}$  threshold before POR initiates operation.

The Power-On Reset (POR) function inhibits operation with the chip disabled (EN pin low). With both input supplies above their POR thresholds, transitioning the EN pin high initiates a soft start interval.

### Soft Start

The POR function initiates the soft start sequence. An internal  $10\mu\text{A}$  current source charges an external capacitor ( $C_{SS}$ ) on the SS pin to 4V. Soft start clamps the error amplifier output (COMP pin) and reference input (+ terminal of error amp) to the SS pin voltage. Figure 3 shows the soft start interval with  $C_{SS} = 0.1\mu\text{F}$ . Initially the clamp on the error amplifier (COMP pin) controls the converter's output voltage. At  $t_1$  in Figure 3, the SS voltage reaches the valley of the oscillator's triangle wave. The oscillator's triangular waveform is compared to the ramping error amplifier voltage. This generates PHASE pulses of increasing width that charge the output capacitor(s). This interval of increasing pulse width continues to  $t_2$ . With sufficient output voltage, the clamp on the reference input controls the output voltage. This is the interval between  $t_2$  and  $t_3$  in Figure 3. At  $t_3$  the SS voltage exceeds the reference voltage and the output voltage is in regulation. This method provides a rapid and controlled output voltage rise.

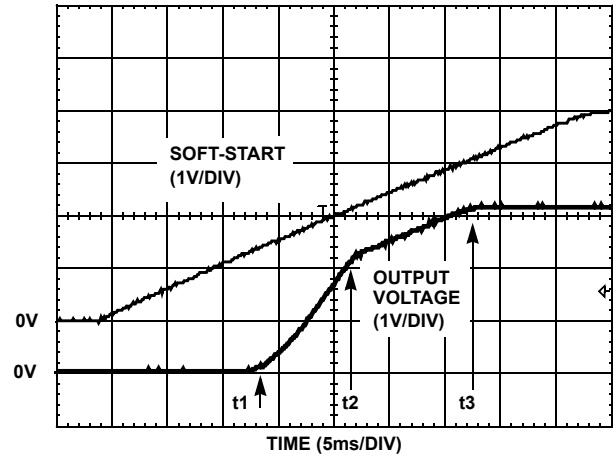

FIGURE 3. SOFT-START INTERVAL

### Over-Current Protection

The over-current function protects the converter from a shorted output by using the upper MOSFET's on-resistance,  $r_{DS(ON)}$  to monitor the current. This method enhances the converter's efficiency and reduces cost by eliminating a current sensing resistor.

The over-current function cycles the soft-start function in a hiccup mode to provide fault protection. A resistor ( $R_{OCSET}$ ) programs the over-current trip level. An internal  $200\mu\text{A}$  (typical) current sink develops a voltage across  $R_{OCSET}$  that is reference to  $V_{IN}$ . When the voltage across the upper MOSFET (also referenced to  $V_{IN}$ ) exceeds the voltage across  $R_{OCSET}$ , the over-current function initiates a soft-start sequence. The soft-start function discharges  $C_{SS}$  with a  $10\mu\text{A}$  current sink and inhibits PWM operation. The soft-start function recharges  $C_{SS}$ , and PWM operation resumes with the error amplifier clamped to the SS voltage. Should an overload occur while recharging  $C_{SS}$ , the soft start function inhibits PWM operation while fully charging  $C_{SS}$  to 4V to complete its cycle. Figure 4 shows this operation with an overload condition. Note that the inductor current increases to over 15A during the  $C_{SS}$  charging interval and causes an over-current trip. The converter dissipates very little power with this method. The measured input power for the conditions of Figure 4 is 2.5W.

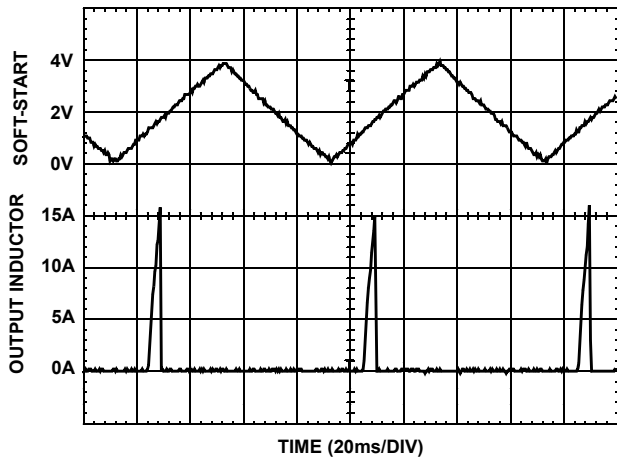

FIGURE 4. OVER-CURRENT OPERATION

The over-current function will trip at a peak inductor current ( $I_{PEAK}$ ) determined by:

$$I_{PEAK} = \frac{I_{OCSET} \cdot R_{OCSET}}{r_{DS(ON)}}$$

where  $I_{OCSET}$  is the internal OCSET current source (200 $\mu$ A - typical). The OC trip point varies mainly due to the MOSFET's  $r_{DS(ON)}$  variations. To avoid over-current tripping in the normal operating load range, find the  $R_{OCSET}$  resistor from the equation above with:

1. The maximum  $r_{DS(ON)}$  at the highest junction temperature.
2. The minimum  $I_{OCSET}$  from the specification table.
3. Determine  $I_{PEAK}$  for  $I_{PEAK} > I_{OUT(MAX)} + (\Delta I)/2$ , where  $\Delta I$  is the output inductor ripple current.

For an equation for the ripple current see the section under component guidelines titled 'Output Inductor Selection'.

A small ceramic capacitor should be placed in parallel with  $R_{OCSET}$  to smooth the voltage across  $R_{OCSET}$  in the presence of switching noise on the input voltage.

### Application Guidelines

#### Layout Considerations

As in any high frequency switching converter, layout is very important. Switching current from one power device to another can generate voltage transients across the impedances of the interconnecting bond wires and circuit traces. These interconnecting impedances should be minimized by using wide, short printed circuit traces. The critical components should be located as close together as possible using ground plane construction or single point grounding.

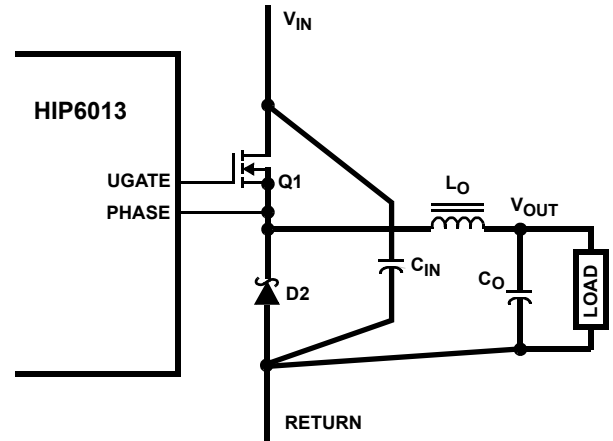

FIGURE 5. PRINTED CIRCUIT BOARD POWER AND GROUND PLANES OR ISLANDS

Figure 5 shows the critical power components of the converter. To minimize the voltage overshoot the interconnecting wires indicated by heavy lines should be part of ground or power plane in a printed circuit board. The components shown in Figure 6 should be located as close together as possible. Please note that the capacitors  $C_{IN}$  and  $C_O$  each represent numerous physical capacitors. Locate the HIP6013 within 3 inches of the MOSFETs, Q1. The circuit traces for the MOSFETs' gate and source connections from the HIP6013 must be sized to handle up to 1A peak current.

Figure 6 shows the circuit traces that require additional layout consideration. Use single point and ground plane construction for the circuits shown. Minimize any leakage current paths on the SS PIN and locate the capacitor,  $C_{SS}$  close to the SS pin because the internal current source is only 10 $\mu$ A. Provide local  $V_{CC}$  decoupling between  $V_{CC}$  and GND pins. Locate the capacitor,  $C_{BOOT}$  as close as practical to the BOOT and PHASE pins.

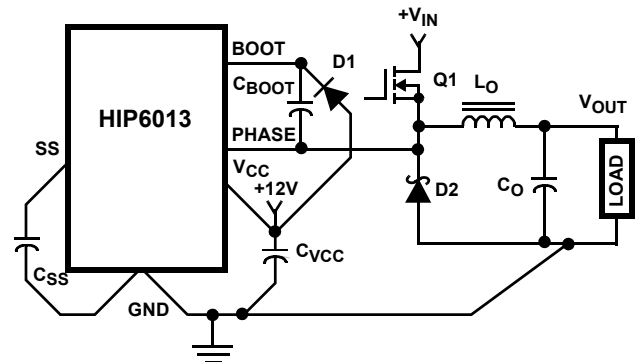
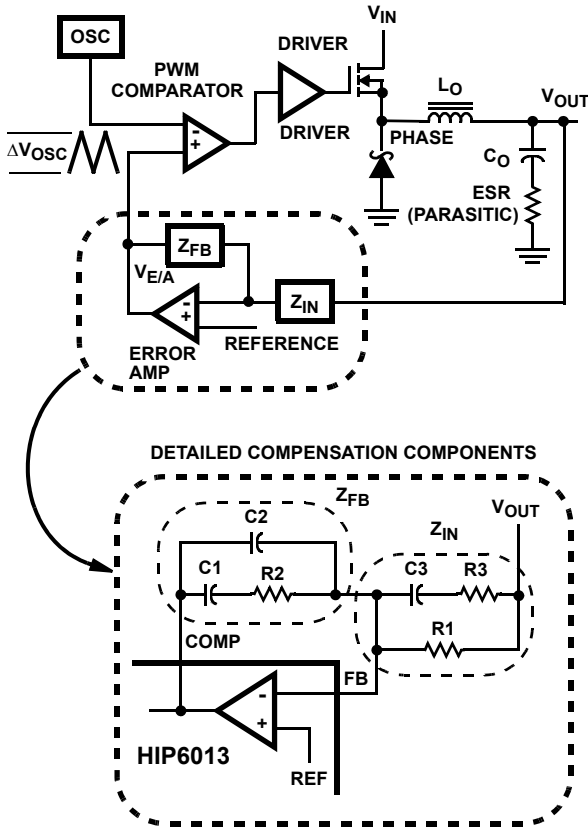

FIGURE 6. PRINTED CIRCUIT BOARD SMALL SIGNAL LAYOUT GUIDELINES

**Feedback Compensation**

Figure 7 highlights the voltage-mode control loop for a synchronous-rectified buck converter. The output voltage (Vout) is regulated to the Reference voltage level. The error amplifier (Error Amp) output (VE/A) is compared with the oscillator (OSC) triangular wave to provide a pulse-width modulated (PWM) wave with an amplitude of Vin at the PHASE node. The PWM wave is smoothed by the output filter (Lo and Co).



**FIGURE 7. VOLTAGE - MODE BUCK CONVERTER COMPENSATION DESIGN**

The modulator transfer function is the small-signal transfer function of Vout/VE/A. This function is dominated by a DC Gain and the output filter (Lo and Co), with a double pole break frequency at FLC and a zero at FESR. The DC Gain of the modulator is simply the input voltage (Vin) divided by the peak-to-peak oscillator voltage ΔVOSC.

**Modulator Break Frequency Equations**

$$F_{LC} = \frac{1}{2\pi \cdot \sqrt{L_O \cdot C_O}} \quad F_{ESR} = \frac{1}{2\pi \cdot (ESR \cdot C_O)}$$

The compensation network consists of the error amplifier (internal to the HIP6013) and the impedance networks ZIN and ZFB. The goal of the compensation network is to provide a closed loop transfer function with the highest 0dB crossing frequency (f0dB) and adequate phase margin. Phase margin is the difference between the closed loop phase at f0dB and 180°. The equations below relate the compensation network's poles, zeros and gain to the components (R1, R2, R3, C1, C2, and C3) in Figure 8. Use these guidelines for locating the poles and zeros of the compensation network:

**Compensation Break Frequency Equations**

$$F_{Z1} = \frac{1}{2\pi \cdot R2 \cdot C1} \quad F_{P1} = \frac{1}{2\pi \cdot R2 \cdot \left(\frac{C1 \cdot C2}{C1 + C2}\right)}$$

$$F_{Z2} = \frac{1}{2\pi \cdot (R1 + R3) \cdot C3} \quad F_{P2} = \frac{1}{2\pi \cdot R3 \cdot C3}$$

1. Pick Gain (R2/R1) for desired converter bandwidth
2. Place 1<sup>ST</sup> Zero Below Filter's Double Pole (~75% FLC)
3. Place 2<sup>ND</sup> Zero at Filter's Double Pole
4. Place 1<sup>ST</sup> Pole at the ESR Zero
5. Place 2<sup>ND</sup> Pole at Half the Switching Frequency
6. Check Gain against Error Amplifier's Open-Loop Gain
7. Estimate Phase Margin - Repeat if Necessary

Figure 8 shows an asymptotic plot of the DC-DC converter's gain vs frequency. The actual Modulator Gain has a high gain peak do to the high Q factor of the output filter and is not shown in Figure 8. Using the above guidelines should give a Compensation Gain similar to the curve plotted. The open loop error amplifier gain bounds the compensation gain. Check the compensation gain at FP2 with the capabilities of the error amplifier. The Closed Loop Gain is constructed on the log-log graph of Figure 8 by adding the Modulator Gain (in dB) to the Compensation Gain (in dB). This is equivalent to multiplying the modulator transfer function to the compensation transfer function and plotting the gain.

The compensation gain uses external impedance networks ZFB and ZIN to provide a stable, high bandwidth (BW) overall loop. A stable control loop has a gain crossing with -20dB/decade slope and a phase margin greater than 45°. Include worst case component variations when determining phase margin.

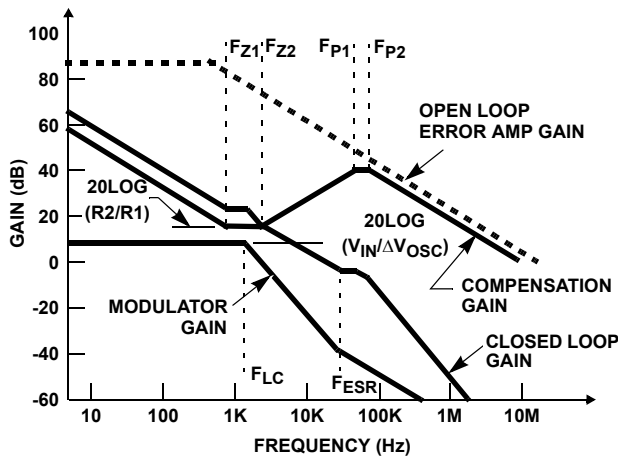

FIGURE 8. ASYMPTOTIC BODE PLOT OF CONVERTER GAIN

### Component Selection Guidelines

#### Output Capacitor Selection

An output capacitor is required to filter the output and supply the load transient current. The filtering requirements are a function of the switching frequency and the ripple current. The load transient requirements are a function of the slew rate (di/dt) and the magnitude of the transient load current. These requirements are generally met with a mix of capacitors and careful layout.

Modern microprocessors produce transient load rates above 1A/ns. High frequency capacitors initially supply the transient and slow the current load rate seen by the bulk capacitors. The bulk filter capacitor values are generally determined by the ESR (effective series resistance) and voltage rating requirements rather than actual capacitance requirements.

High frequency decoupling capacitors should be placed as close to the power pins of the load as physically possible. Be careful not to add inductance in the circuit board wiring that could cancel the usefulness of these low inductance components. Consult with the manufacturer of the load on specific decoupling requirements. For example, Intel recommends that the high frequency decoupling for the Pentium-Pro be composed of at least forty (40) 1.0μF ceramic capacitors in the 1206 surface-mount package.

Use only specialized low-ESR capacitors intended for switching-regulator applications for the bulk capacitors. The bulk capacitor's ESR will determine the output ripple voltage and the initial voltage drop after a high slew-rate transient. An aluminum electrolytic capacitor's ESR value is related to the case size with lower ESR available in larger case sizes. However, the equivalent series inductance (ESL) of these capacitors increases with case size and can reduce the usefulness of the capacitor to high slew-rate transient loading. Unfortunately, ESL is not a specified parameter. Work with your capacitor supplier and measure the capacitor's impedance with frequency to select a suitable

component. In most cases, multiple electrolytic capacitors of small case size perform better than a single large case capacitor.

#### Output Inductor Selection

The output inductor is selected to meet the output voltage ripple requirements and minimize the converter's response time to the load transient. The inductor value determines the converter's ripple current and the ripple voltage is a function of the ripple current. The ripple voltage and current are approximated by the following equations:

$$\Delta I = \frac{V_{IN} - V_{OUT}}{F_s \times L_O} \cdot \frac{V_{OUT}}{V_{IN}} \quad \Delta V_{OUT} = \Delta I \times ESR$$

Increasing the value of inductance reduces the ripple current and voltage. However, the large inductance values reduce the converter's response time to a load transient.

One of the parameters limiting the converter's response to a load transient is the time required to change the inductor current. Given a sufficiently fast control loop design, the HIP6013 will provide either 0% or 100% duty cycle in response to a load transient. The response time is the time required to slew the inductor current from an initial current value to the transient current level. During this interval the difference between the inductor current and the transient current level must be supplied by the output capacitor. Minimizing the response time can minimize the output capacitance required.

The response time to a transient is different for the application of load and the removal of load. The following equations give the approximate response time interval for application and removal of a transient load:

$$t_{RISE} = \frac{L_O \times I_{TRAN}}{V_{IN} - V_O} \quad t_{FALL} = \frac{L_O \times I_{TRAN}}{V_O}$$

where: I<sub>TRAN</sub> is the transient load current step, t<sub>RISE</sub> is the response time to the application of load, and t<sub>FALL</sub> is the response time to the removal of load. With a +5V input source, the worst case response time can be either at the application or removal of load and dependent upon the output voltage setting. Be sure to check both of these equations at the minimum and maximum output levels for the worst case response time.

#### Input Capacitor Selection

Use a mix of input bypass capacitors to control the voltage overshoot across the MOSFETs. Use small ceramic capacitors for high frequency decoupling and bulk capacitors to supply the current needed each time Q1 turns on. Place the small ceramic capacitors physically close to the MOSFETs and between the drain of Q1 and the anode of Schottky diode D2.

The important parameters for the bulk input capacitor are the voltage rating and the RMS current rating. For reliable

operation, select the bulk capacitor with voltage and current ratings above the maximum input voltage and largest RMS current required by the circuit. The capacitor voltage rating should be at least 1.25 times greater than the maximum input voltage and a voltage rating of 1.5 times is a conservative guideline. The RMS current rating requirement for the input capacitor of a buck regulator is approximately 1/2 the DC load current.

For a through hole design, several electrolytic capacitors (Panasonic HFQ series or Nichicon PL series or Sanyo MV-GX or equivalent) may be needed. For surface mount designs, solid tantalum capacitors can be used, but caution must be exercised with regard to the capacitor surge current rating. These capacitors must be capable of handling the surge-current at power-up. The TPS series available from AVX, and the 593D series from Sprague are both surge current tested.

**MOSFET Selection/Considerations**

The HIP6013 requires an N-Channel power MOSFET. It should be selected based upon  $r_{DS(ON)}$ , gate supply requirements, and thermal management requirements.

In high-current applications, the MOSFET power dissipation, package selection and heatsink are the dominant design factors. The power dissipation includes two loss components; conduction loss and switching loss. The conduction losses are the largest component of power dissipation for the MOSFET. Switching losses also contribute to the overall MOSFET power loss (see the equations below). These equations assume linear voltage-current transitions and are approximations. The gate-charge losses are dissipated by the HIP6013 and don't heat the MOSFET. However, large gate-charge increases the switching interval,  $t_{SW}$ , which increases the upper MOSFET switching losses. Ensure that the MOSFET is within its maximum junction temperature at high ambient temperature by calculating the temperature rise according to package thermal-resistance specifications. A separate heatsink may be necessary depending upon MOSFET power, package type, ambient temperature and air flow.

$$P_{COND} = I_O^2 \times r_{DS(ON)} \times D$$

$$P_{SW} = \frac{1}{2} I_O \times V_{IN} \times t_{SW} \times F_s$$

Where: D is the duty cycle =  $V_O / V_{IN}$ ,  
 $t_{SW}$  is the switching interval, and  
 $F_s$  is the switching frequency.

Standard-gate MOSFETs are normally recommended for use with the HIP6013. However, logic-level gate MOSFETs can be used under special circumstances. The input voltage, upper gate drive level, and the MOSFET's absolute gate-to-source voltage rating determine whether logic-level MOSFETs are appropriate.

Figure 9 shows the upper gate drive (BOOT pin) supplied by a bootstrap circuit from  $V_{CC}$ . The boot capacitor,  $C_{BOOT}$  develops a floating supply voltage referenced to the PHASE pin. This supply is refreshed each cycle to a voltage of  $V_{CC}$  less the boot diode drop ( $V_D$ ) when the lower MOSFET, Q2 turns on. A logic-level MOSFET can only be used for Q1 if the MOSFET's absolute gate-to-source voltage rating exceeds the maximum voltage applied to  $V_{CC}$ .

Figure 10 shows the upper gate drive supplied by a direct connection to  $V_{CC}$ . This option should only be used in converter systems where the main input voltage is +5VDC or less. The peak upper gate-to-source voltage is approximately  $V_{CC}$  less the input supply. For +5V main power and +12VDC for the bias, the gate-to-source voltage of Q1 is 7V. A logic-level MOSFET is a good choice for Q1 and a logic-level MOSFET is a good choice for Q1 under these conditions.

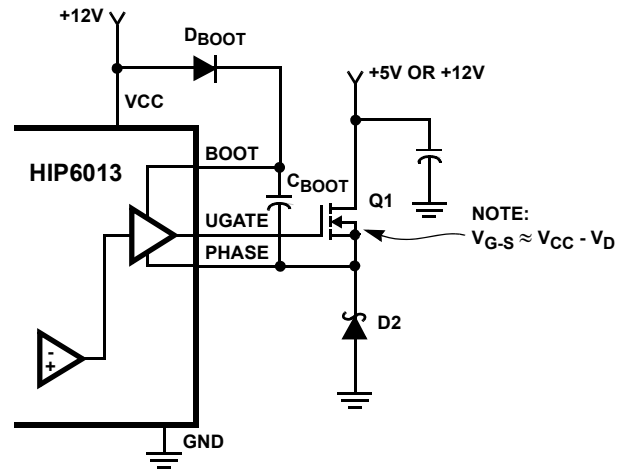

FIGURE 9. UPPER GATE DRIVE - BOOTSTRAP OPTION

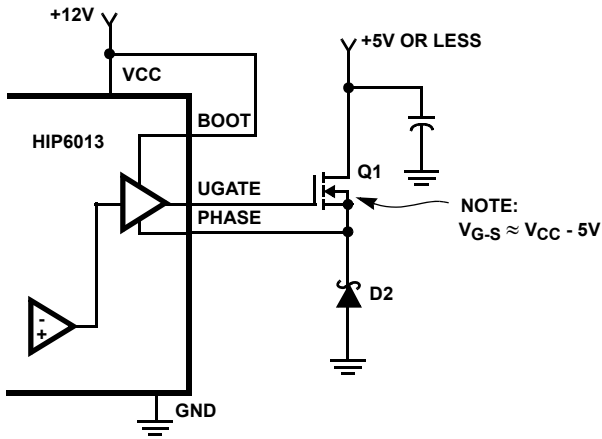

FIGURE 10. UPPER GATE DRIVE - DIRECT V<sub>CC</sub> DRIVE OPTION

**Schottky Selection**

Rectifier D2 conducts when the upper MOSFET Q1 is off. The diode should be a Schottky type for low power losses. The power dissipation in the Schottky rectifier is approximated by:

$$P_{COND} = I_O \times V_f \times (1 - D)$$

Where: D is the duty cycle =  $V_O/V_{IN}$ , and  $V_f$  is the schottky forward voltage drop

In addition to power dissipation, package selection and heatsink requirements are the main design tradeoffs in choosing the Schottky rectifier. Since the three factors are interrelated, the selection process is an iterative procedure. The maximum junction temperature of the rectifier must remain below the manufacturer’s specified value, typically 125°C. By using the package thermal resistance specification and the Schottky power dissipation equation (shown above), the junction temperature of the rectifier can be estimated. Be sure to use the available airflow and ambient temperature to determine the junction temperature rise.

**HIP6013 DC-DC Converter Application Circuit**

The figure below shows a DC-DC converter circuit for a microprocessor application, originally designed to employ the HIP6007 controller. Given the similarities between the HIP6007 and HIP6013 controllers, the circuit can be implemented using the HIP6013 controller without any modifications. However, given the expanded reference

voltage tolerance range, the HIP6013-based converter may require additional output capacitance. Detailed information on the circuit, including a complete Bill-of-Materials and circuit board description, can be found in application note AN9722. See Intersil's home page on the web: <http://www.intersil.com>.

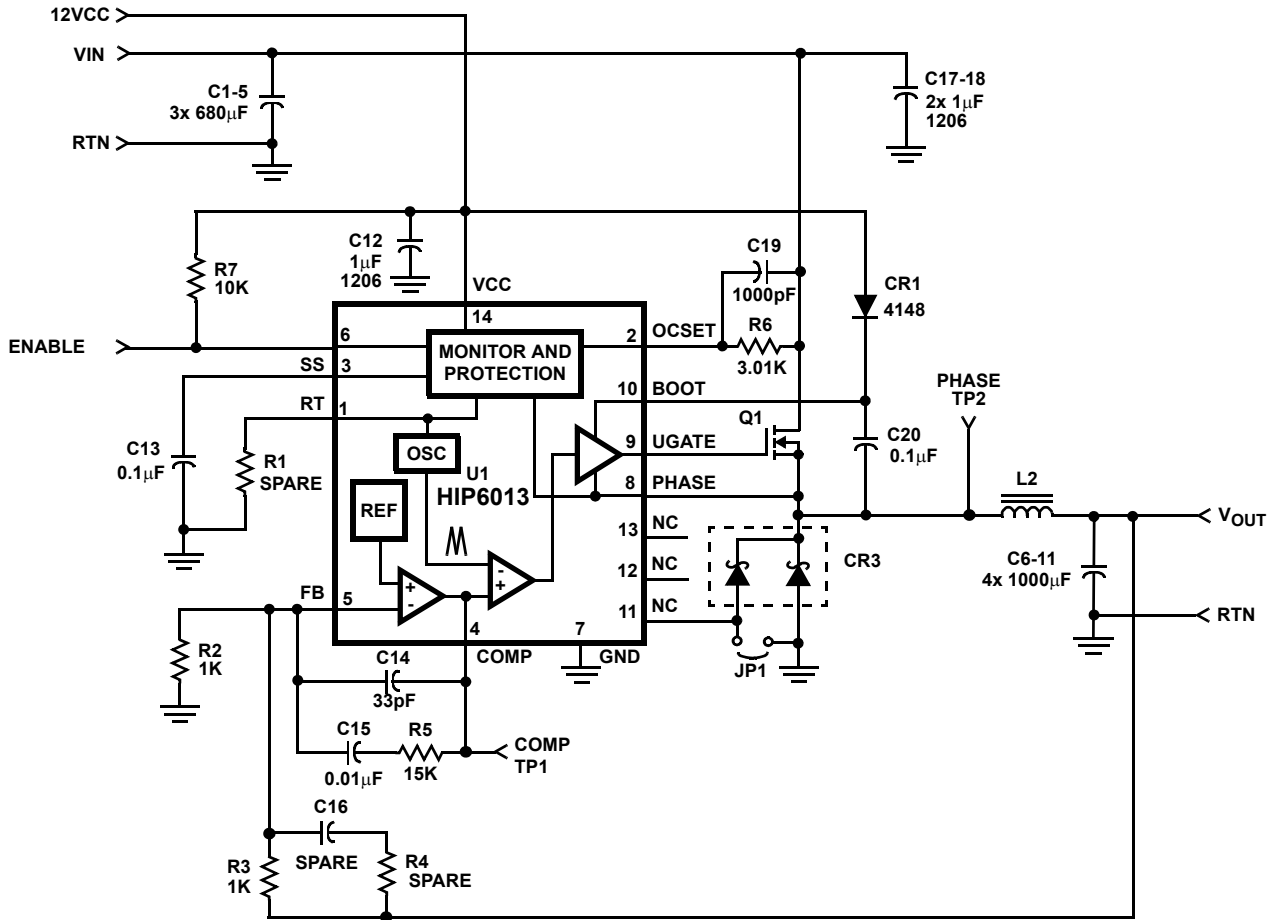

**Component Selection Notes:**

- C1-C3 - 3 each 680µF 25W VDC, Sanyo MV-GX or equivalent.
- C6-C9 - 4 each 1000µF 6.3W VDC, Sanyo MV-GX or equivalent.
- L1 - Core: Micrometals T60-52; Winding: 14 Turns of 17AWG.
- CR1 - 1N4148 or equivalent.
- CR3 - 15A, 35V Schottky, Motorola MBR1535CT or equivalent.
- Q1 - Intersil MOSFET; RFP25N05.

**FIGURE 11. DC-DC CONVERTER APPLICATION CIRCUIT**

For additional products, see [www.intersil.com/en/products.html](http://www.intersil.com/en/products.html)

Intersil products are manufactured, assembled and tested utilizing ISO9001 quality systems as noted in the quality certifications found at [www.intersil.com/en/support/qualandreliability.html](http://www.intersil.com/en/support/qualandreliability.html)

*Intersil products are sold by description only. Intersil Corporation reserves the right to make changes in circuit design, software and/or specifications at any time without notice. Accordingly, the reader is cautioned to verify that data sheets are current before placing orders. Information furnished by Intersil is believed to be accurate and reliable. However, no responsibility is assumed by Intersil or its subsidiaries for its use; nor for any infringements of patents or other rights of third parties which may result from its use. No license is granted by implication or otherwise under any patent or patent rights of Intersil or its subsidiaries.*

For information regarding Intersil Corporation and its products, see [www.intersil.com](http://www.intersil.com)