



Chipsmall Limited consists of a professional team with an average of over 10 year of expertise in the distribution of electronic components. Based in Hongkong, we have already established firm and mutual-benefit business relationships with customers from,Europe,America and south Asia,supplying obsolete and hard-to-find components to meet their specific needs.

With the principle of “Quality Parts,Customers Priority,Honest Operation,and Considerate Service”,our business mainly focus on the distribution of electronic components. Line cards we deal with include Microchip,ALPS,ROHM,Xilinx,Pulse,ON,Everlight and Freescale. Main products comprise IC,Modules,Potentiometer,IC Socket,Relay,Connector.Our parts cover such applications as commercial,industrial, and automotives areas.

We are looking forward to setting up business relationship with you and hope to provide you with the best service and solution. Let us make a better world for our industry!



Contact us

Tel: +86-755-8981 8866 Fax: +86-755-8427 6832

Email & Skype: info@chipsmall.com Web: www.chipsmall.com

Address: A1208, Overseas Decoration Building, #122 Zhenhua RD., Futian, Shenzhen, China



Introduction

Each generation of computer microprocessor brings performance advances in computing power. Performance improvements are made possible by advances in fabrication technology that enable greater device density. Newer processors are operating at lower voltages and higher clock speeds both of which contribute to greater demands on the microprocessor core voltage supply in terms of higher peak currents and higher current-slew rates.

Intersil's family of multi-phase DC-DC converter solutions provide the ideal solution to supply the core-voltage needs of present and future high-performance microprocessors.

Intersil HIP6302 and HIP6601

The HIP6302 controller IC works with two HIP6601A or HIP6603A single-channel driver ICs or a single HIP6602A dual-channel driver IC [3] to form a highly integrated solution for high-current, high slew-rate applications. The HIP6302 regulates output voltage, balances load currents and provides protective functions for two synchronous-rectified buck-converter channels.

provides feedback for droop compensation and over-current protection. A five-bit DAC provides a digital interface to program the 1% accurate reference and a window comparator toggles PGOOD if the output voltage is out of range and acts to protect the load in case of over voltage. For more detailed descriptions of the HIP6302 functionality, refer to the HIP6302 Data Sheet [1].

The HIP6601A is a driver IC capable of delivering up to 2A of gate-charging current for rapidly switching both MOSFETs in a synchronous-rectified bridge. The HIP6601A accepts a single logic input to control both upper and lower MOSFETs. Adaptive shoot-through protection is provided on both switching edges to provide optimal dead time, and bootstrap circuitry permits greater enhancement of the upper MOSFET. For a more detailed description of the HIP6601A, refer to the HIP6601A Data Sheet [2].

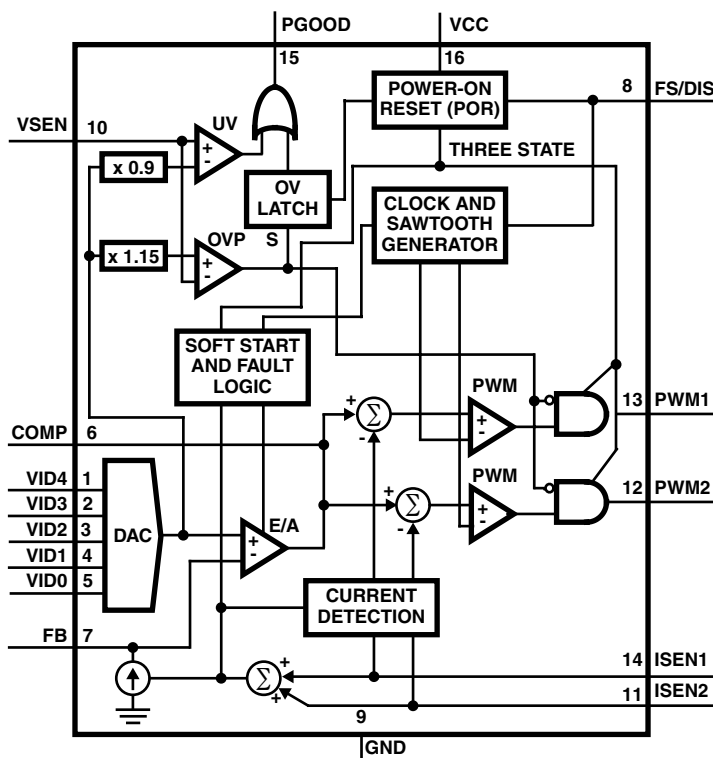

FIGURE 1. HIP6302 BLOCK DIAGRAM

The integrated high-bandwidth error amplifier provides voltage regulation, while current-sense circuitry maintains phase-current balance between the two power channels and

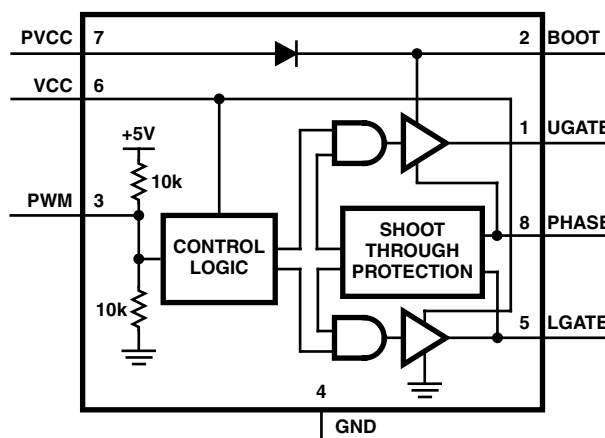

FIGURE 2. HIP6601A BLOCK DIAGRAM

The HIP6302EVAL1 Board and Reference Design

With the VID jumpers set to 1.7V (00110), the evaluation board meets the output voltage and current specifications indicated in Table 1.

TABLE 1. HIP6302EVAL1 OUTPUT PARAMETERS

	MIN	MAX
Static Regulation	1.65V	1.75V
Transient Regulation	1.60V	1.85V
Over-Voltage Protection	1.90V	2.00V
Continuous Load Current	-	35A
Over-Current Trip Level	41A	57A
Load-Current Transient	-	35A/ μ s

The HIP6302EVAL1 evaluation board incorporates a reference design intended to meet the core-voltage requirements for AMD Athlon™ microprocessors up to 35A. Additional circuitry is provided to facilitate circuit evaluation including input and output power connectors, VID jumpers, numerous probe points, an LED power-good indicator, and a load-transient generator.

Powering the HIP6302EVAL1

For convenience, the HIP6302EVAL1 provides two methods of making input power connections. The 20-pin header, J1, interfaces with a standard ATX power supply and may be the most convenient method of powering the board.

J2, J3, and J4 are standard banana-jack connectors that can be used to supply power using bench-top power supplies. These inputs provide greater versatility in testing and design validation by allowing the 12V and 5V power-input voltage levels to be varied independently. In this way power-on level and power-sequencing issues can be easily examined.

To start the evaluation board, insert the 20-pin connector from an ATX supply into J1. If using bench-top supplies, connect a 12V supply to J2 and a 5V supply to J3. Connect the grounds from both supplies to J4.

Important

There are two things to consider when using bench-top supplies. If the 5V supply is applied prior to the 12V supply, the HIP6302 will begin operating before the HIP6601As. This allows the HIP6302 to complete its soft-start cycle before the drivers are capable of switching power to the output. When the 12V power input is then applied, there is a large transient as the controller tries to instantly bring the output to its full-voltage level. This can result in an overcurrent protection cycle and an abnormal start-up waveform. It can be avoided by applying 5V supply after or at the same time as the 12V supply or by using an ATX power supply.

The second problem can occur when operating the transient load generator. Not all bench-top and ATX power supplies are capable of responding to load transients, and they may allow a momentary voltage dip on VCC5. This can activate the power-on-reset function in the HIP6302 and cause the output power to cycle. It can be remedied by connecting a 5600 μ F or larger capacitor between VCC5 and ground. The capacitor, if necessary, simulates the distributed capacitance that exists on the computer motherboard.

Start Up

The waveforms in Figure 3 demonstrate the normal start-up sequence with the HIP6302EVAL1 connected to a 55m Ω load. After FS/EN is released, V_{CORE} exhibits a linear ramp until reaching its 1.7V set point. The gradual increase of V_{CORE} over approximately 5ms limits the current required from the input supply, ICC5, to a level that does not strain the supply. The HIP6302 asserts PGOOD once V_{CORE} is within regulation limits.

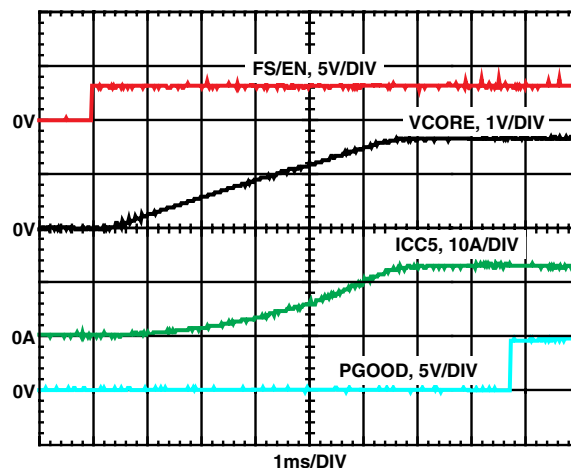

FIGURE 3. HIP6302EVAL1 START-UP WAVEFORMS

Transient Response

The HIP6302EVAL1 is equipped with a load-transient generator that applies a 0–36A transient load current with rise and fall rates of approximately 35A/ μ s. The duration of the transient is between 100 μ s and 200 μ s, and the repetition rate is kept low in order to limit power dissipation in the load MOSFETs and resistors. Removal of the HI/LO jumper (JP2) causes the current to decrease from about 36A to about 31A. The load-transient generator operates when the HIP6302EVAL1 is properly connected to a 12V power source and SW1 is in the ON position. Operation ceases when SW1 is moved into the OFF position or 12V is removed from the board.

The HIP6302EVAL1 achieves the specified transient performance while maintaining a favorable balance between low cost, high efficiency and small profile. When the duty cycle changes rapidly in response to a transient load current, the inductor current immediately begins to change in order to meet the demand. During the time the inductor current is increasing, the output-filter capacitors are supplying the load. It follows that the amount of required capacitance decreases as the capability of the inductors to rapidly assume the load current increases.

Figure 4 shows the core voltage, inductor current, and PWM signals changing in response to the transient load current. The upper waveform shows the core voltage deviating from its no-load setting of 1.72V to a minimum of about 1.62V upon the application of current. The voltage then settles to its 1.67V full-load setting. On load removal, the core voltage peaks at a level of 1.78V before settling again to its 1.72V no-load setting. Although the specified operating range allows deviations as low as 1.60V and as high as 1.85V, a minimum of 20mV is reserved to allow for the reference tolerance and the tolerances of other components that contribute to the overall system accuracy.

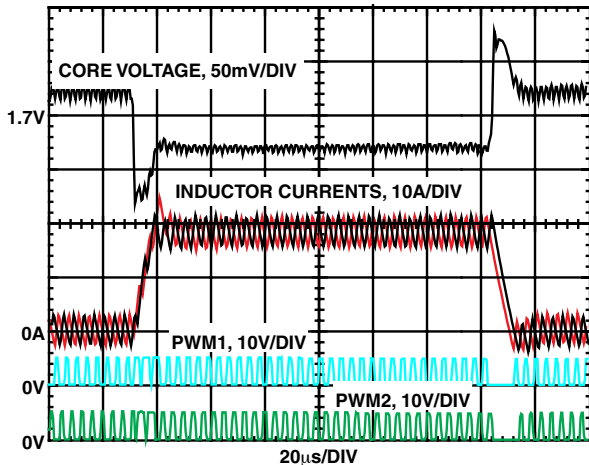

FIGURE 4. HIP6302EVAL1 TRANSIENT RESPONSE

Figure 5 is a close-up showing the core-voltage, inductor-current and PWM signals responding at the leading edge of the transient load current. The PWM signals increase to their maximum duty cycle of 75% on the first pulse following the start of the transient. The inductor currents begin to increase immediately and are carrying all of the load within 10µs. The very fast transient response is due to the precision 18MHz error amplifier and optimal compensation of the control loop.

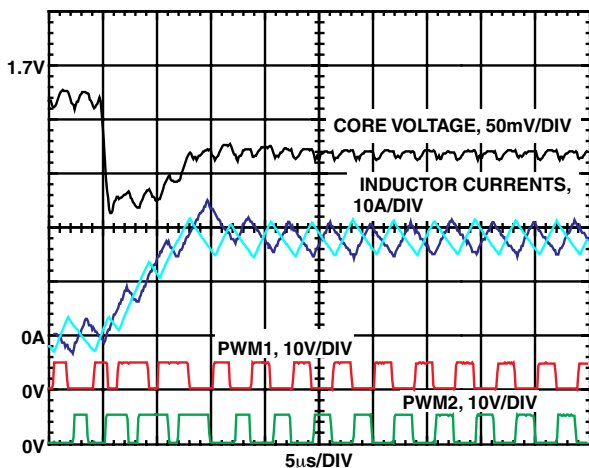

FIGURE 5. TRANSIENT-RESPONSE LEADING EDGE

The close up in Figure 6 shows the core-voltage, inductor-current and PWM signals changing in response to the trailing edge of the transient load current. Again, the duty cycles immediately decrease to zero, and the inductors begin shedding load current at the maximum rate. Note that the inductor currents briefly go negative as the transient settles. The capacitors are slightly over charged at the end of the transient, and the discharge path is in the reverse direction through the inductors.

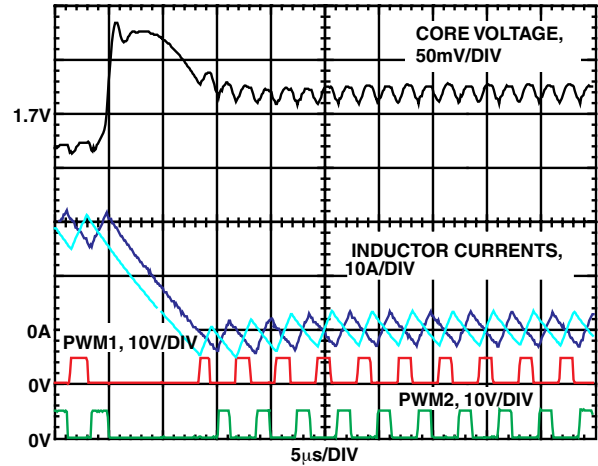

FIGURE 6. TRANSIENT-RESPONSE TRAILING EDGE

Overcurrent Protection

When the current out of either ISEN pin exceeds 82µA, the HIP6302 detects an overcurrent condition and responds by placing the PWM outputs into a high-impedance state. This signals the HIP6601 to turn off both upper and lower MOSFETs in order to remedy the overcurrent condition. This behavior is seen in Figure 7 where PWM1 goes immediately to 2.5VDC when the output current reaches approximately 50A. The output voltage then quickly falls to zero.

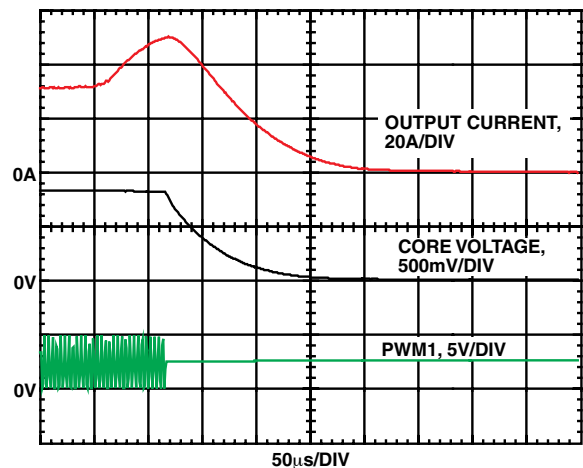

FIGURE 7. OVERCURRENT BEHAVIOR

After the initial over-current trip, the HIP6302 waits for a period of time equal to $2048/f_{SW}$ (f_{SW} is the switching frequency) before initiating a soft-start cycle. If the over-load condition remains, another over-current trip will occur before the end of the soft-start sequence. This repetitive over-current cycling is illustrated in Figure 8, and will continue indefinitely unless the fault is cleared or power to the converter is removed. Because of the wait period, the worst case power delivered during overcurrent cycling is equal to 45% of the power delivered during normal operation at full load. Therefore, indefinite over-current cycling does not create a thermal problem for the circuit.

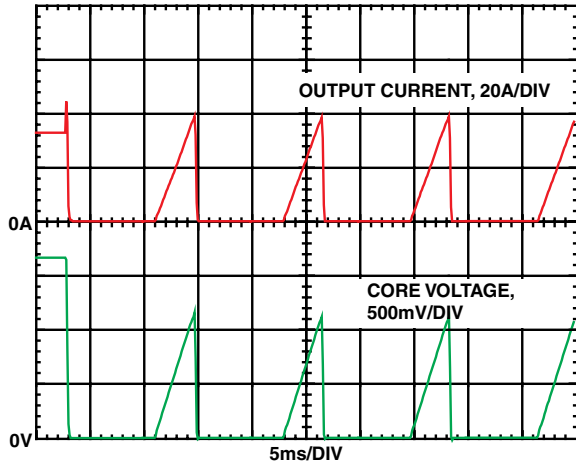

FIGURE 8. OVERCURRENT BEHAVIOR

Efficiency

Figure 9 shows the efficiency versus current plot for the HIP6302EVAL1 for 5A through 35A. The measurements were made at room temperature with natural convection cooling only..

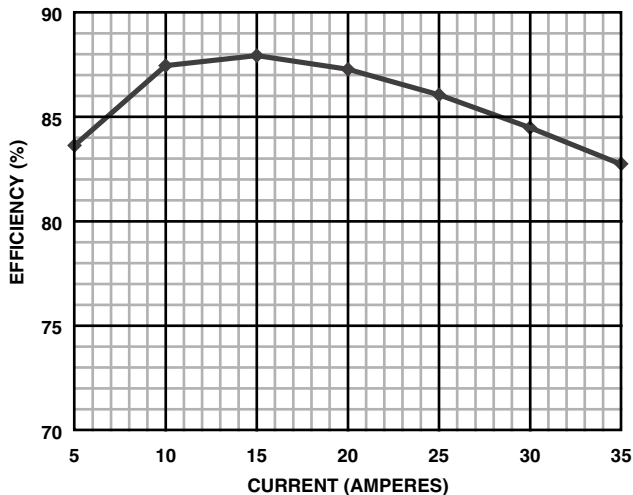

FIGURE 9. EFFICIENCY vs CURRENT

Summary

The HIP6302EVAL1 is intended to provide a convenient platform to evaluate the performance of the HIP6302 - HIP6601A chip set in the specific implementation indicated in Table 1. The design demonstrates a favorable trade off between low cost, high efficiency, and small footprint. The following pages include schematic, bill of materials, and layout drawings to facilitate implementation of this solution. The evaluation board is simple and convenient to operate, and test points are available to evaluate the most commonly tested parameters. Example waveforms are given for reference.

The HIP6302 and HIP6601A provide a versatile 2-phase power solution for low-voltage applications from 25A to approximately 40A, and together they result in the most effective solution available.

References

For Intersil documents available on the internet, see web site <http://www.intersil.com/>

Intersil Technical Support 1 (888) INTERSIL

- [1] *HIP6302 Data Sheet*, Intersil Corporation, Power Management Products Division, 2000. (<http://www.intersil.com/>).
- [2] *HIP6601A, HIP6603A Data Sheet*, Intersil Corporation, Power Management Products Division, 2000.
- [3] *HIP6602A Data Sheet*, Intersil Corporation, Power Management Products Division, 2000.

Schematic

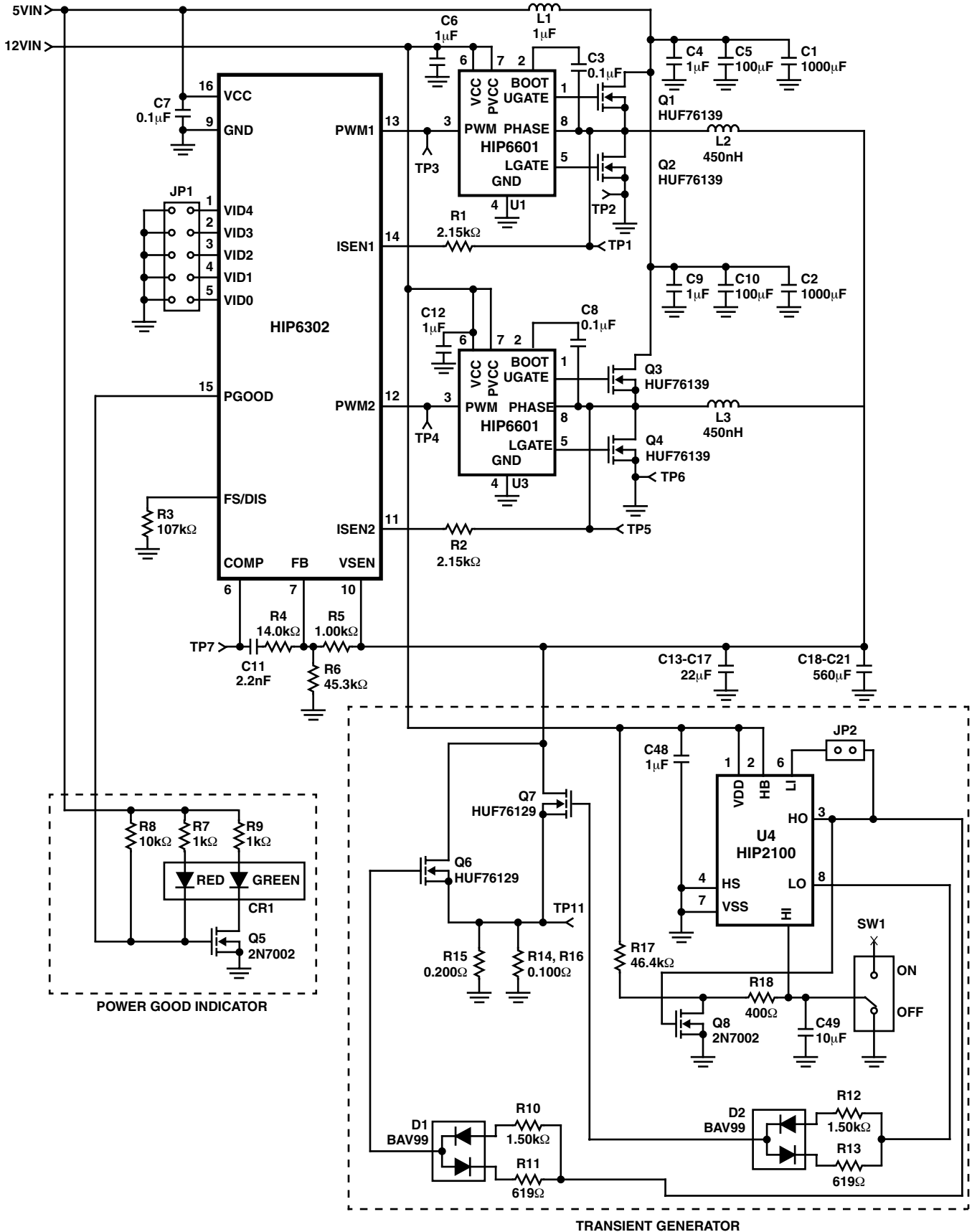

Application Note AN9888

Bill of Materials

QTY	REFERENCE	DESCRIPTION	PACKAGE	VENDOR	PART NO.
1	CR1	RED/GREEN LED	SMT	Lumex	SSL-LXA3025IGC
2	C1, C2	1000 μ F, 10V, Aluminum Capacitor	Radial	Panasonic	EEUFC1A102L
3	C3, C7, C8	0.1 μ F, 25V, Y5V, Ceramic Capacitor	0603	Various	
5	C4, C6, C9, C12, C48	1.0 μ F, 25V, Y5V, Ceramic Capacitor	0805	Various	
2	C5, C10	100 μ F, 16V, OS-CON Capacitor	Radial	Sanyo	16SPS100M
1	C11	2.2nF, 50V, X7R, Ceramic Capacitor	0603	Various	
5	C13-C17, C49	10 μ F, 10V, X7R, Ceramic Capacitor	1206	Various	
4	C19, C20, C22, C23	560 μ F, 4V, OS-CON Capacitor	Radial	Sanyo	4SP560M
2	C18, C21	Spare	Radial		
24	C24-C47	Spare	1206		
2	D1, D2	Dual Diode	SOT23	Various	BAV99
1	JP1	5-Position Jumper Header	100mil Centers	Berg	68000-236
5		Jumpers		Berg	71363-102
1	JP2	1-Position Header	100mil Centers	Berg	68000-236
1		Jumper		Berg	71363-102
1	J1	ATX Power Header		Berg	39-29-9203
2	J2, J3	Female Banana Connector, Red		Johnson Components	111-0702-001
1	J4	Female Banana Connector, Black		Johnson Components	111-0703-001
2	J5, J6	Terminal Connector		Burndy	KPA8CTP
1	L1	1 μ H, T30-26, 6T AWG18	400x300mil	Falco	TTIG0803-127
2	L2, L3	450nH, T60-8/90, 5T AWG14	700x500mil	Falco	TTIB1506-478
4	Q1, Q2, Q3, Q4	Power MOSFETs	TO-263AB	Intersil	HUF76139S3S
2	Q5, Q8	General Purpose MOSFET	SOT23	Various	2N7002
2	Q6, Q7	Power MOSFET	TO-252AA	Intersil	HUF76129D3S
2	R1, R2	Resistor, 2.15k Ω , 1%, 1/10W	0603	Various	
1	R3	Resistor, 107k Ω , 1%, 1/10W	0603	Various	
1	R4	Resistor, 14.0k Ω , 1%, 1/10W	0603	Various	
1	R5	Resistor, 1.00k Ω , 1%, 1/10W	0603	Various	
1	R6	Resistor, 45.3k Ω , 1%, 1/10W	0603	Various	
2	R7, R9	Resistor, 1.0k Ω , 5%, 1/8W	0805	Various	
1	R8	Resistor, 10k Ω , 5%, 1/10W	0603	Various	
2	R10, R12	Resistor, 1.50k Ω , 1%, 1/8W	0805	Various	
2	R11, R13	Resistor, 619 Ω , 1%, 1/8W	0805	Various	
2	R14, R16	Resistor, 0.100 Ω , 1%, 1W	2512	Vishay	WSL2512R100FB43
1	R15	Resistor, 0.200 Ω , 1%, 1W	2512	Vishay	WSL2512R200FB43
1	R17	Resistor, 46.4k Ω , 1%, 1/8W	0805	Various	
1	R18	Resistor, 400 Ω , 1%, 1/8W	0805	Various	
1	SW1	Switch, SPDT	SMT	C&K Components	GT11MSCKE
6	TP1, TP3, TP4, TP5, TP7, TP8	Small Test Point		Jolo	SPCJ-123-01
3	TP2, TP6, TP10	Large Test Point		Keystone	1514-2
2	TP9, TP11	Probe Socket		Tektronics	1314353-00
2	U1, U3	Synchronous Buck Driver IC	8-Lead SOIC	Intersil	HIP6601ACB
1	U2	Multiphase Buck Controller IC	16-Lead SOIC	Intersil	HIP6302CB
1	U4	MOSFET Driver IC	8-Lead SOIC	Intersil	HIP2100IB

Layout Drawing - Components

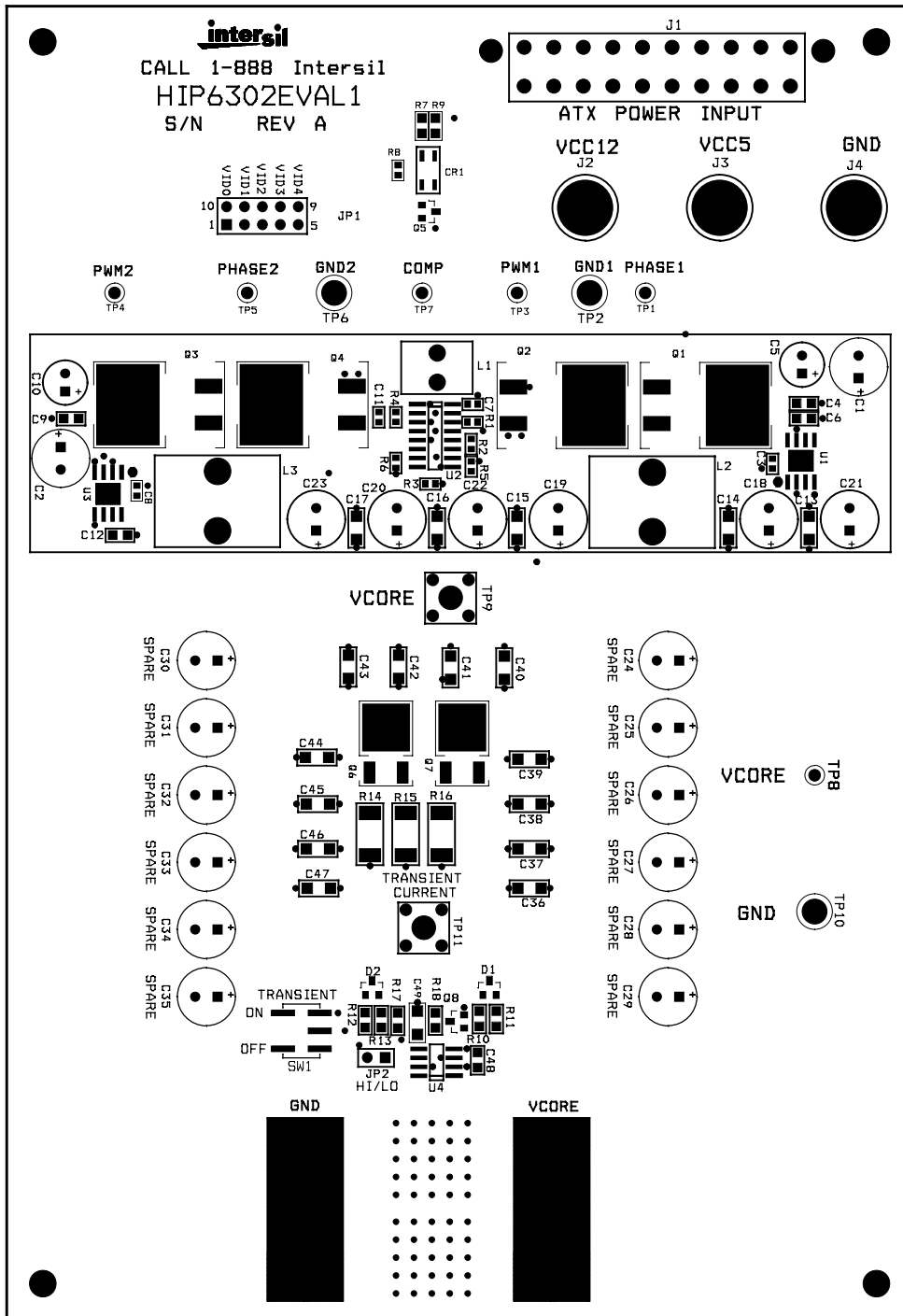

Layout Drawing - Top Copper

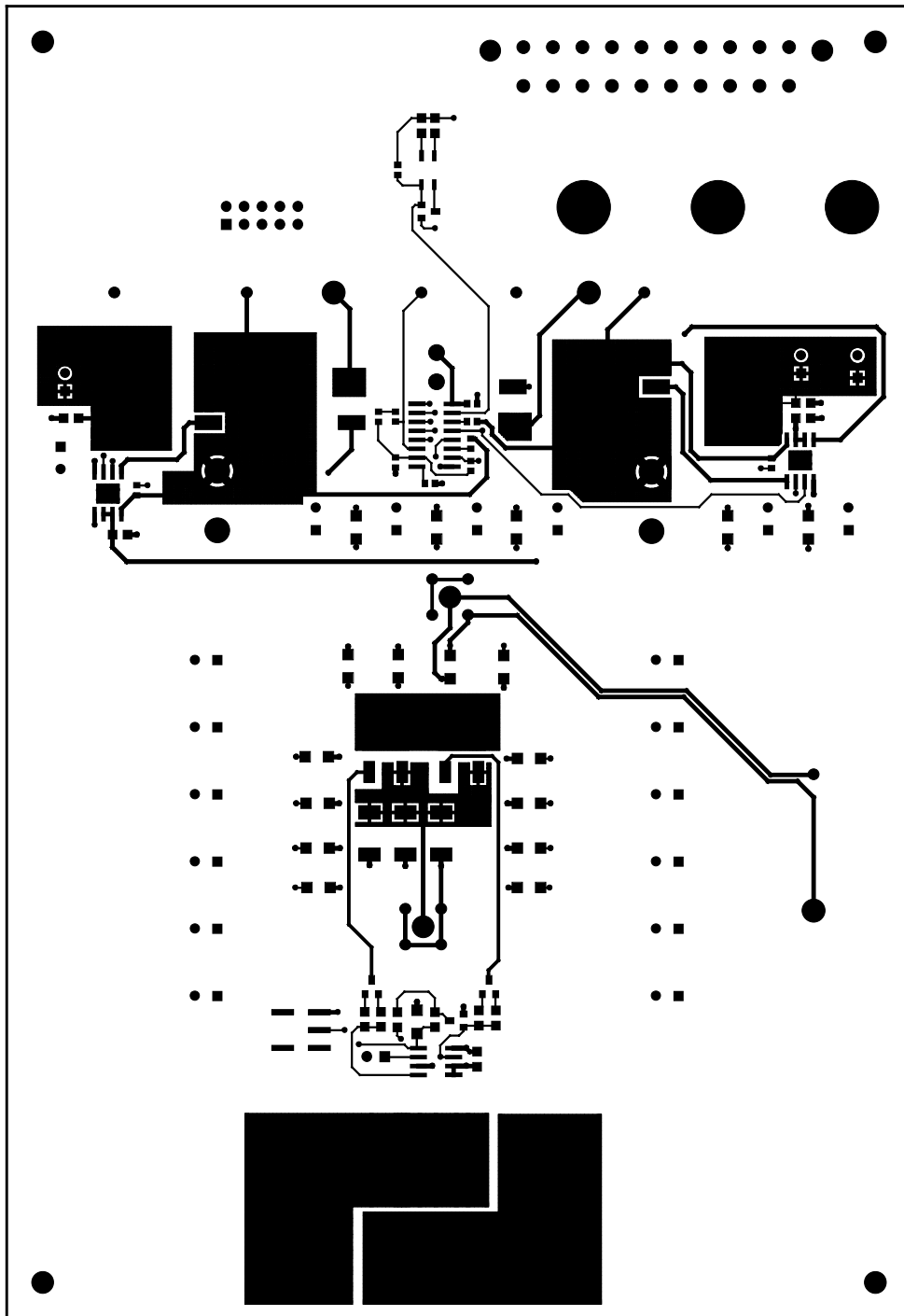

Layout Drawing - Ground Plane

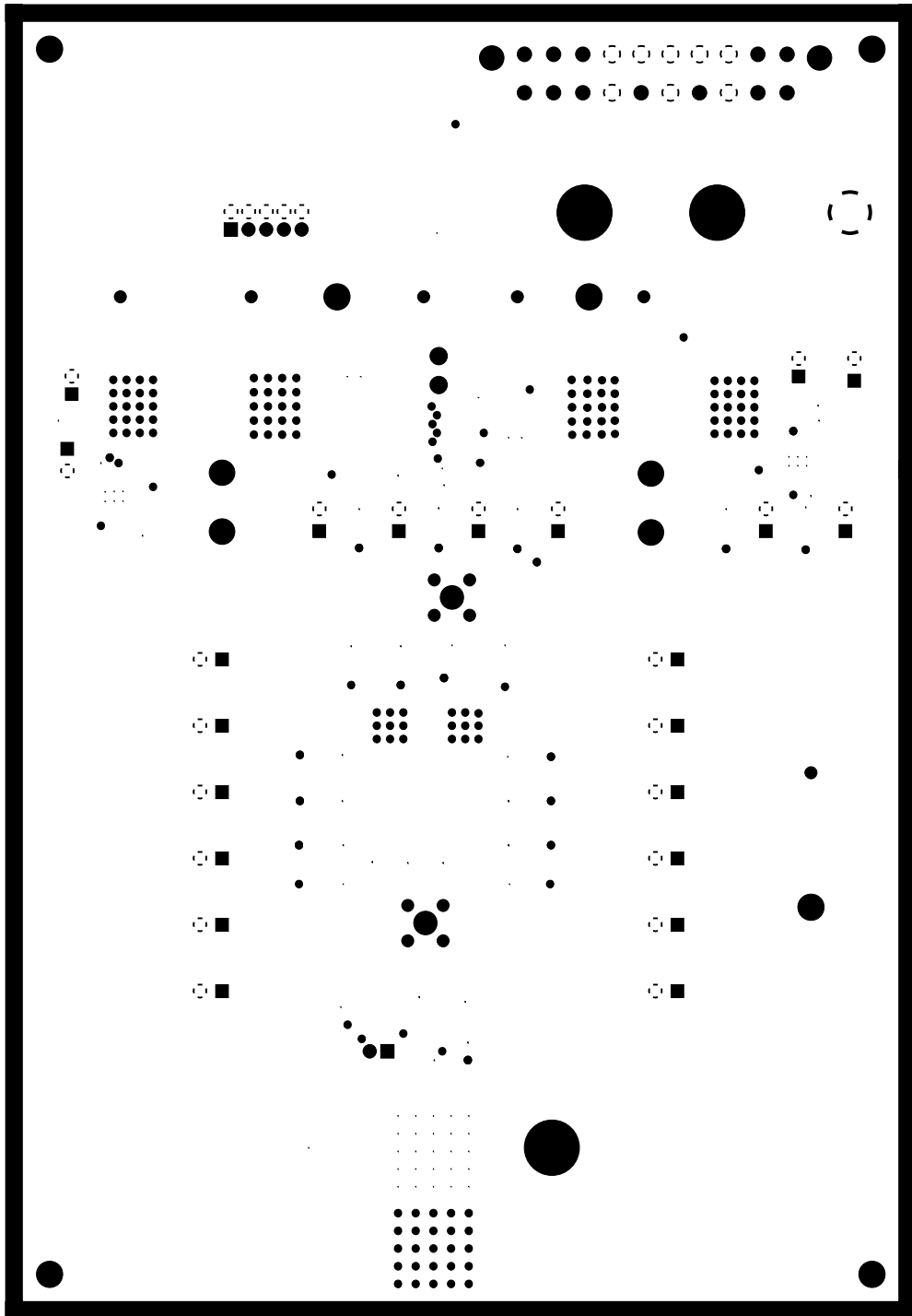

Layout Drawing - Power Plane

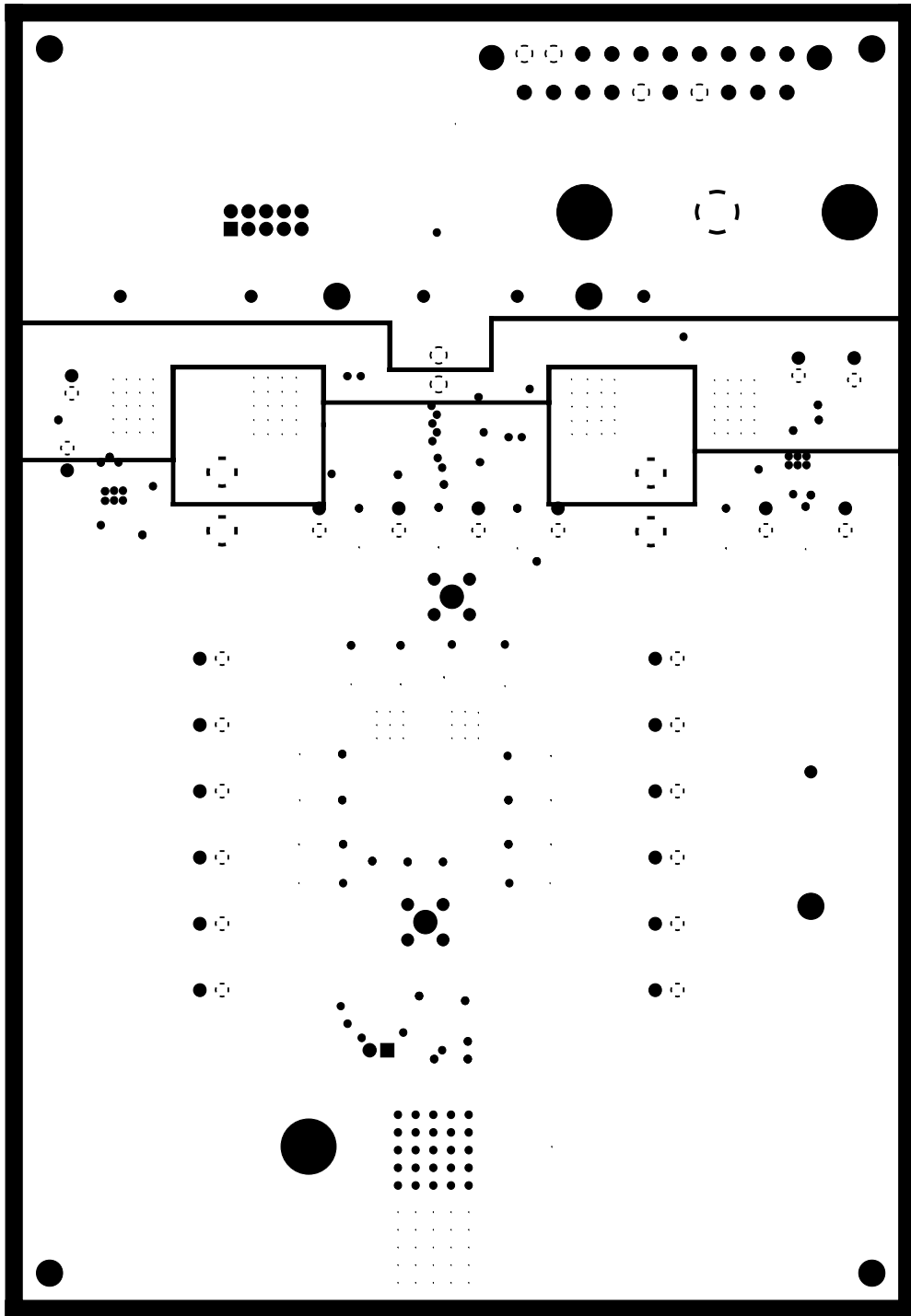

Layout Drawing - Bottom Copper

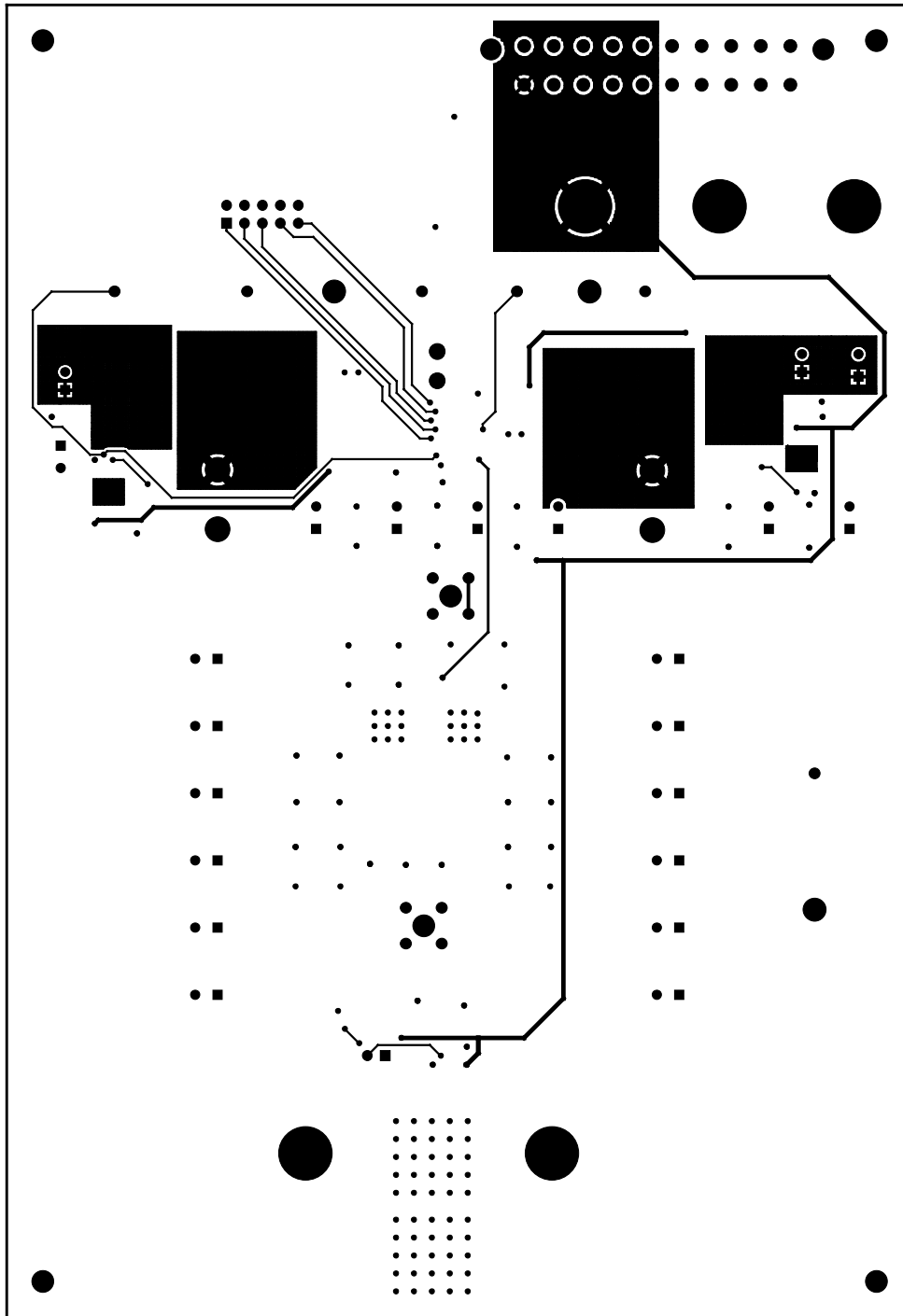

All Intersil U.S. products are manufactured, assembled and tested utilizing ISO9000 quality systems. Intersil Corporation's quality certifications can be viewed at www.intersil.com/design/quality

Intersil products are sold by description only. Intersil Corporation reserves the right to make changes in circuit design, software and/or specifications at any time without notice. Accordingly, the reader is cautioned to verify that data sheets are current before placing orders. Information furnished by Intersil is believed to be accurate and reliable. However, no responsibility is assumed by Intersil or its subsidiaries for its use; nor for any infringements of patents or other rights of third parties which may result from its use. No license is granted by implication or otherwise under any patent or patent rights of Intersil or its subsidiaries.

For information regarding Intersil Corporation and its products, see www.intersil.com