



Chipsmall Limited consists of a professional team with an average of over 10 year of expertise in the distribution of electronic components. Based in Hongkong, we have already established firm and mutual-benefit business relationships with customers from,Europe,America and south Asia,supplying obsolete and hard-to-find components to meet their specific needs.

With the principle of “Quality Parts,Customers Priority,Honest Operation,and Considerate Service”,our business mainly focus on the distribution of electronic components. Line cards we deal with include Microchip,ALPS,ROHM,Xilinx,Pulse,ON,Everlight and Freescale. Main products comprise IC,Modules,Potentiometer,IC Socket,Relay,Connector.Our parts cover such applications as commercial,industrial, and automotives areas.

We are looking forward to setting up business relationship with you and hope to provide you with the best service and solution. Let us make a better world for our industry!



Contact us

Tel: +86-755-8981 8866 Fax: +86-755-8427 6832

Email & Skype: info@chipsmall.com Web: www.chipsmall.com

Address: A1208, Overseas Decoration Building, #122 Zhenhua RD., Futian, Shenzhen, China



RF Receiver + Decoder Hybrid

Features

- Miniature RF Receiver and Decoder
- Advanced Keeloq Decoding
- AM Range up to 100 Metres
- FM Range up to 150 Metres
- Easy Learn Transmitter Feature.
- Outputs, Momentary or Latching & Serial Data.
- Direct Led Drive Shows Data Reception
- Single Supply 5V
- Flash re-programmable
- HIR6 Low Power Version (<1mA)
- Directly compatible with 110 Series
- Compatible with RF600E
- EMC Compliant for use in Europe
- FCC Certified for use in USA

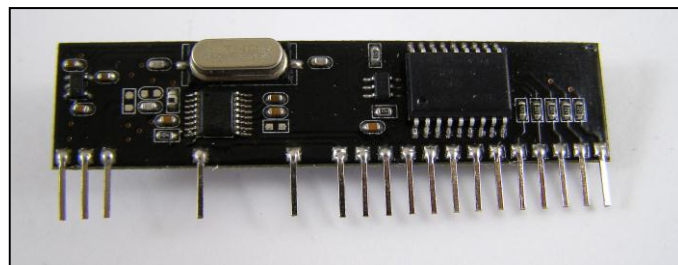

Applications

- General Remote Control Systems.
- Garage Door Openers.
- Car, Caravan, Motorcycle Alarms
- Remote Switching.
- Remote Gates.
- Paging

Description

A range of miniature single in line (SIL) hybrid modules providing complete four channel Radio Receiver/Decoder systems available in either AM or FM. When used with the 110-AM or 120-FM series pocket keyfobs a complete remote telemetry system is obtained with up to 150 metres range.

The module consists of a front end super-heterodyne or super-regen RF receiver with an embedded microcontroller decoding a highly secure Keeloq protocol signal.

The module has an easy-to-use 'LEARN' facility, and is capable of learning up to 50 unique keyfob encoders.

The module requires a 5V power supply and provides a direct LED drive showing data reception and four digital data outputs. The outputs may be programmed for momentary or latching configuration.

The modules have flash re-programmability feature to enable field re-programming of the controller.

Part Numbers

Part Number	Description	Compatible Transmitters
HiRK-315AP	Superheterodyne Receiver Decoder AM 315MHz	110 Series transmitter keyfobs or 102 'A' Series transmitters
HiRK-433AP	Superheterodyne Receiver Decoder AM 433MHz	
HIRK-433FP	Low Power Rx Decoder FM 433MHz	120 Series transmitters 102 'F' series transmitters

HiRK Version

This range of modules provides a high sensitivity and selective Superhetrodyne receiver, combined with flash programmable controller, supplied pre-programmed to operate with a suitable Keeloq Transmitter encoder.

The range from such a system can be up to 150 metres Line of Sight (LOS).

Custom versions of this product are available; please contact our sales department for further details

Pin Descriptions Superhetrodyne Versions (HiRK series)

Pin No	Name	Description
1	<i>Vcc-RF</i>	+5V Supply Voltage – RF section
2	<i>GND-RF</i>	RF Ground
3	<i>ANT</i>	Connect Antenna to this input
7	<i>GND-RF</i>	RF Ground
11	<i>GND-AF</i>	AF Ground
13	<i>RSSI</i>	Received Signal Strength Indicator (RSSI)
14	<i>O/P-AF</i>	Raw Data output from RF receiver (CMOS/TTL signal)
15	<i>Vcc-digital</i>	+5V Supply Voltage – digital section
16	<i>Vdd-digital</i>	Digital Ground
17	<i>MCLR**</i>	Pulls Microcontroller into reset if connected to Ground May be left unconnected if not required (internally tied high)
18	<i>Link2</i>	Connect to GND to make link, may be left O/C if not required
19	<i>Link1</i>	Connect to GND to make link, may be left O/C if not required
20	<i>PSW</i>	Programming Switch input. Used when learning new transmitters and erasing data.
21	<i>LED</i>	External LED sink output, can be connected directly to cathode of external LED. Connect Anode of the LED directly to +5V. Indicates Data reception, and programming status.
22	<i>O/P2</i>	Active High data Output 2 (has a 220Ω series resistor)
23	<i>O/P3</i>	Active High data Output 3 (has a 220Ω series resistor)
24	<i>O/P4</i>	Active High data Output 4 (has a 220Ω series resistor) or Battery Low Output: Indicates when the transmitter battery is low voltage (Output is high when battery low) Serial Data Output: Outputs the Serial ID of transmitter encoder. Please see RF600 for serial data format and timings
25	<i>O/P1</i>	Active High data Output 1 (has a 220Ω series resistor)

Compatibility with older versions of this module

** AM-HiRK: To remain compatible with previous versions of the product, this pin may be removed and ignored.

AM-HiRH : Please contact sales for part HiRK-433P534

HiRK Application Circuit

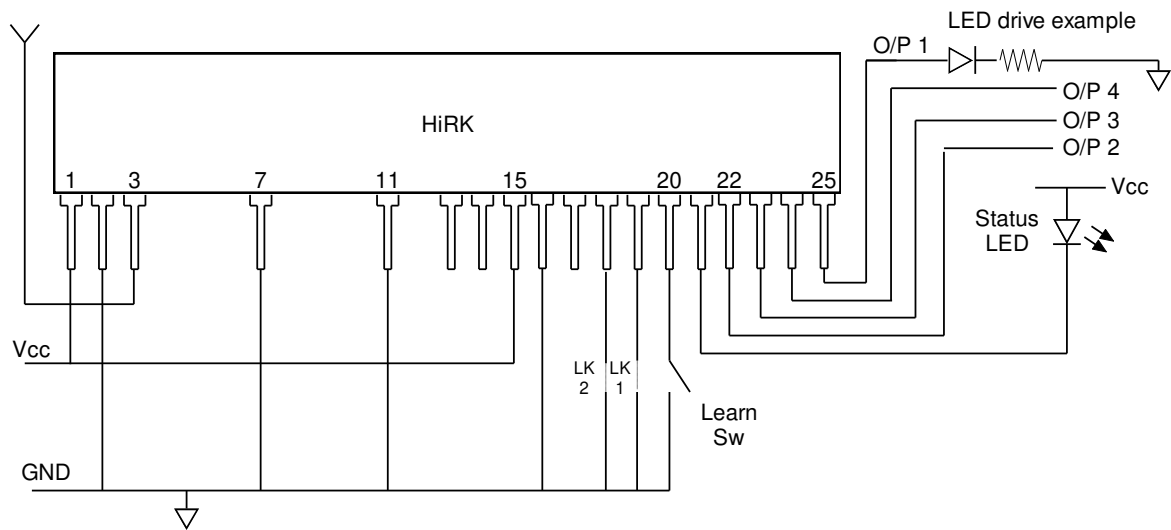

Data Outputs

Outputs are digital CMOS/TTL (PIC Micro) with a series 220Ω protection resistor. Outputs are all normally low, active high.

Link Positions		Digital Outputs			
Link1	Link2	O/P 1	O/P 2	O/P 3	O/P 4
Open	Open	Latch	Latch	Latch	Latch
Open	Connected	Mom	Mom	Mom	Mom
Connected	Open	Mom	Mom	Latch	Tx Bat Low
Connected	Connected	Latch	Latch	Mom	Serial Data

Mom: This output is valid for the duration of valid key press of the transmitter switch

Latch: This output changes state on each valid transmitter switch press.

Transmitter Switch / Output Table				
	O/P 1	O/P 2	O/P 3	O/P 4
1 Switch Keyfob	Centre Switch			
2 Switch Keyfob	LH Switch	RH Switch		
3 Switch Keyfob	LH Switch	RH Switch	Top Switch	
4 Switch Keyfob	Sw 1	Sw 2	Sw 3	Sw 4

Custom versions of this product are available, please contact our sales department for further details.



Learning a New Transmitter Encoder (Applies to all Decoders)

1. Briefly press the programming switch (PSW).
2. Learn LED will illuminate.
3. Depress the transmitter once, Learn LED will extinguish.
4. Depress the transmitter again, Learn LED will flash. (approx 10secs).
5. Wait for Learn LED to stop flashing.
6. This transmitter will now operate the system.

Erasing The Memory – all modules

1. Press and hold PSW for 10 seconds.
2. Release PSW and LED flashes while the module erases its memory.

Antenna Design

For 99% of applications a 17cm piece of wire is quite adequate for 433 MHz modules. The range achieved from the system is dependent on the choice and position of the antenna. The space around the antenna is as important as the antenna itself. The optimum position is to locate the antenna so that it protrudes directly out the top of the transmitter box. If this is not possible due to other design constraints, try to keep the antenna, and in particular, the 'HOT' end away from other metal in the system such as transformers, batteries and PCB tracks, especially ground planes.

For further information on Antenna design please see our full product catalogue.

Serial Data Output

Both the HiRK and HiR6 decoders provide a serial data output. (Selectable option on HiRK) This outputs the serial number, button and battery status of the transmitter encoder it has successfully received. It also gives an indication of which inputs of the encoder have been activated and the status of the encoder battery. This data has an idle state of logic '1' and may be fed via an RS232 type driver circuit (e.g. MAX232) which may then connect directly to a PC serial port. (An RS232 level serial data output is provided on SA123 & RFEVAL2).

Serial data is output continually whilst data is being received from the transmitter. i.e. this output is valid regardless of whether the encoder has been learnt to the decoder or not. If the user requires the serial number of pre-learnt encoders only, then the serial output should be configured only to output data when one of the digital outputs from the decoder is asserted which occurs only when an encoder has been pre-learnt.)

The data received by the decoder (from the encoder) is checked for correct Manchester coding (it is not KeeLoq decrypted) and the following data is output from the Serial Data output pin.

- The 7 digit KeeLoq serial number.
- The KeeLoq button data and transmitter battery state.
- A carriage return character and a line feed character.

Please note that older versions of the HIRK used a different data format of 57.6K 7 Data Bits and 1 stop bit, these modules will be prefixed with AR4 on the end of the part number or below. These modules may still be ordered but we would highly recommend that the new HIRK modules (AR5 and above) are incorporated into new products.

Serial Data Format

Serial Data is sent as a stream of ASCII characters at 9.6K baud. The character format is 8 data bits with 1 stop bit, no parity.

A serial data string is output every time a valid transmitter packet is received. Due to the nature of the KeeLoq packet there will be a minimum gap between each serial data string of 150mSec.

10 characters are sent with the following format;

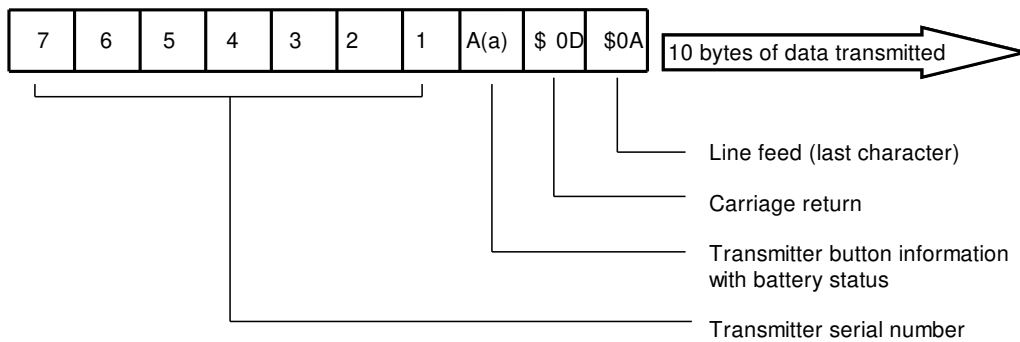

Output from SD1 pin

The Transmitter Serial Number: is made up of 7 ASCII characters from the following group: 0 1 2 3 4 5 6 7 8 9 A B C D E F. The most significant serial number digit is transmitted first. This provides a total of 28million possible serial numbers.

The KeeLoq Button Status is transmitted as an ASCII character in the range A to O or if the low battery bit is asserted (encoder battery is low) then in the range a to o. KeeLoq data bits S0, S1, S2 and S3 then make up the ASCII byte least significant bits D0, D1, D2 and D3.

If a single encoder button is pressed, say S0, then character A will be sent (or if low battery, a).

If encoder button S1 is pressed then B (or b) will be sent.

If S0 and S1 are both pressed simultaneously then character C (or c) will be sent.

If all KeeLoq encoder buttons are simultaneously pressed then character O (or o) will be sent.

Examination of the ASCII bit patterns shows that this allows single or multiple encoder button presses to be decoded by the ASCII receiving device.

Examples of Serial Data output:

For a three button keyfob with serial number 2345678, the serial data output when encoder transmission is decoded would be as follows:

If S1 is pressed: 2345678A (2345678a if the battery voltage in the transmitter is low)

If S2 is pressed: 2345678B (2345678b if the battery voltage in the transmitter is low)

If S1 and S2 are pressed together: 2345678C (2345678c if the battery voltage in the transmitter is low)

If S4 is pressed: 2345678H (2345678h if the battery voltage in the transmitter is low)

HIRK-315AP / HIRK-433AP



Absolute Maximum Ratings

Supply Voltage (+5Vcc to GND).....-0.3 to +6 Volts.
 Storage Temperature.....-30 to +85° Celsius.
 Operating Temperature..... -20 to +70° Celsius.

Technical Specifications

HiRK AM Modules

Ambient temperature = 25° Celsius.

Electrical Specification	Min	Typical	Max	Dimension	Note
Supply Voltage	4.5	5.0	5.5	V	
Supply Current		6		mA	
Receiver Frequency		315.0		MHz	stock frequency
Receiver Frequency		433.92		MHz	stock frequency
Working Frequency (custom Frequencies Available)	200		450	MHz	Please contact Sales Dept
Data output voltage: (any data output)					
Logic Low			0.6	V	I out = 8.5mA
Logic High	Vdd - .7			V	I out = 8.5mA
Data output current: (any data output)					
Logic Low			-25	mA	
Logic High			10	mA	
Turn on Time		20		ms	
-3dB Bandwidth		+/- 400		KHz	
R.F Sensitivity (100% AM)		-106		dBm	
Level of Emitted Spectrum		-70		dBm	
EMC Compliance		Complies to ETS300-339			
Operating Temperature Range	-25		+80	°C	

HiRK FM Modules

Electrical Characteristics	Min	Typical	Max	Dimension	Notes
Supply Voltage (Vcc)	4.5	5	5.5	V	
Supply Current (Operating)		5.7	6.8	mA	
Receiver Frequency		433.92		MHz	
R.F Sensitivity (100% AM) 433MHZ version		-103		dBm	
3dB Bandwidth		+/-150		KHz	
Data Rate	300		9,600	Hz	
Turn on Time			5	mSecs	1
Turn on Time		8		mSecs	2
Level of Emitted Spectrum			-70	dBm	
Low Level Output Voltage			0.8	V	I = 200uA
High Level Output Voltage	Vcc-1			V	I = 200uA
Operating Temperature Range	-25		+80	°C	

HIRK-315AP / HIRK-433AP



Mechanical Details

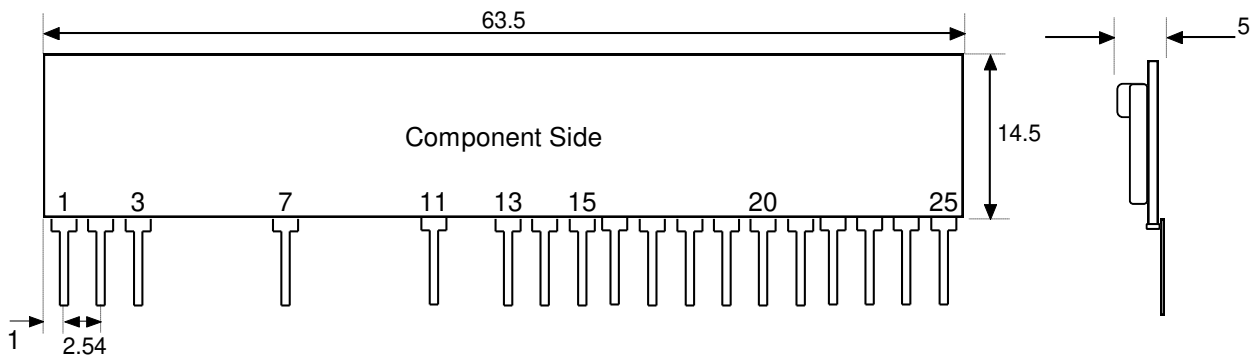

Notes

Dims in mm
Pins on 0.1" pitch
Pin Dims :0.25 x 0.50 mm

Flash Programming the on board Microcontroller

The on-board microcontroller may be programmed using the circuit as below. This may be connected directly to a PICSTART+ programmer using the In Circuit Programming Serial cable (ICSP), please see datasheet DS021 which describes the programming process in more detail and lists other circuit requirements.

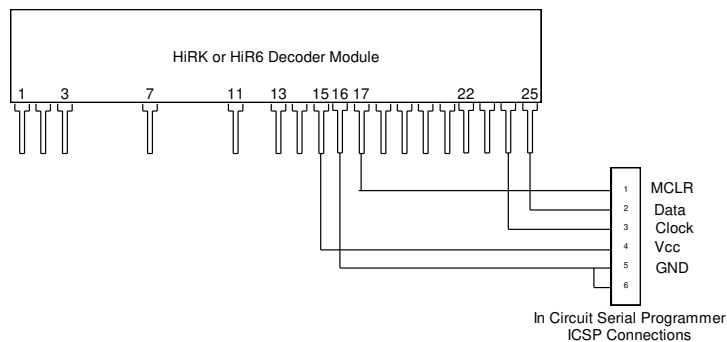

RF Solutions Ltd. Recycling Notice

Meets the following EC Directives:

DO NOT

Discard with normal waste, please recycle.



ROHS Directive 2002/95/EC

Specifies certain limits for hazardous substances.

WEEE Directive 2002/96/EC

Waste electrical & electronic equipment. This product must be disposed of through a licensed WEEE collection point.

RF Solutions Ltd., fulfills its WEEE obligations by membership of an approved compliance scheme.



Waste Batteries and Accumulators Directive 2006/66/EC

Where batteries are fitted, before recycling the product, the batteries must be removed and disposed of at a licensed collection point.

Environment Agency producer registration number:
WEE/JB0104WV.

Disclaimer:

Whilst the information in this document is believed to be correct at the time of issue, RF Solutions Ltd does not accept any liability whatsoever for its accuracy, adequacy or completeness. No express or implied warranty or representation is given relating to the information contained in this document. RF Solutions Ltd reserves the right to make changes and improvements to the product(s) described herein without notice. Buyers and other users should determine for themselves the suitability of any such information or products for their own particular requirements or specification(s). RF Solutions Ltd shall not be liable for any loss or damage caused as a result of user's own determination of how to deploy or use RF Solutions Ltd's products. Use of RF Solutions Ltd products or components in life support and/or safety applications is not authorised except with express written approval. No licences are created, implicitly or otherwise, under any of RF Solutions Ltd's intellectual property rights. Liability for loss or damage resulting or caused by reliance on the information contained herein or from the use of the product (including liability resulting from negligence or where RF Solutions Ltd was aware of the possibility of such loss or damage arising) is excluded. This will not operate to limit or restrict RF Solutions Ltd's liability for death or personal injury resulting from its negligence.

www.rfsolutions.co.uk

RF Solutions Ltd

William Alexander House, William Way, Burgess Hill, West Sussex, RH15 9AG

Sales: +44(0)1444 227 910

Tech Support: +44(0)1444 227909

