



Chipsmall Limited consists of a professional team with an average of over 10 year of expertise in the distribution of electronic components. Based in Hongkong, we have already established firm and mutual-benefit business relationships with customers from,Europe,America and south Asia,supplying obsolete and hard-to-find components to meet their specific needs.

With the principle of “Quality Parts,Customers Priority,Honest Operation,and Considerate Service”,our business mainly focus on the distribution of electronic components. Line cards we deal with include Microchip,ALPS,ROHM,Xilinx,Pulse,ON,Everlight and Freescale. Main products comprise IC,Modules,Potentiometer,IC Socket,Relay,Connector.Our parts cover such applications as commercial,industrial, and automotives areas.

We are looking forward to setting up business relationship with you and hope to provide you with the best service and solution. Let us make a better world for our industry!



Contact us

Tel: +86-755-8981 8866 Fax: +86-755-8427 6832

Email & Skype: info@chipsmall.com Web: www.chipsmall.com

Address: A1208, Overseas Decoration Building, #122 Zhenhua RD., Futian, Shenzhen, China



HL-C1 SERIES

Related Information

- General terms and conditions..... F-7
- Sensor selection guide P.1055~
- Glossary of terms / General precautions.....P.1493 / P.1501
- About laser beam.....P.1499~



Warning: This product is classified as a Class 2 / Class 3B Laser Product in IEC / JIS standards and a Class II / Class IIIb Laser product in FDA regulations 21 CFR 1040.10. Never look at or touch the direct laser beam and its reflection.

High speed of 100 μs, Ultra high-speed & stable measurement for a variety of measurement objects

100 μs, fast sampling rate

Ultra high-speed sampling of 100 μs has now been achieved. Thus enabling ultra high-speed measurement of rotating, vibrating and moving objects.

Resolution of 1 μm 0.039 mil, linearity of ±0.1 % F.S.

Now available with ultra-precise 1 μm **0.039 mil** resolution measurement capability (**HL-C105□**) and a linearity of ±0.1 % F.S. (for all models).

High precision measurement is now possible, unaffected by the surface condition of the detected object

All deficiencies inherent in the conventional PSD sensing method have now been solved. Whereas the PSD method measures position information from the center of gravity of the total light quantity distribution of the light spots connected along each light element, the linear image sensor method measures the peak position values of the light spots themselves. This advancement now makes high-precision measurement possible, regardless of the surface condition of the object whether for metal hairline surface cracks or for non-reflective black rubber.

Change in measurement data due to color difference (White ceramic / Black rubber)

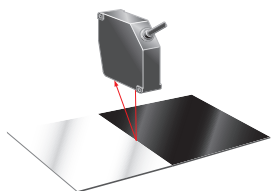

HL-C108B-BK(linear image sensor method)

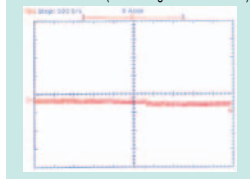

PSD method

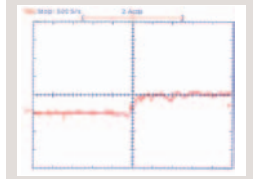

Principle For detection of a V-shaped groove

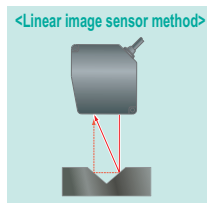

As the sensor measures the peak position of the light spot, it is not affected by secondary reflected light, resulting in no error.

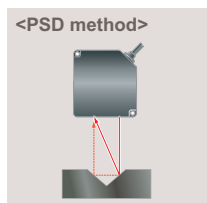
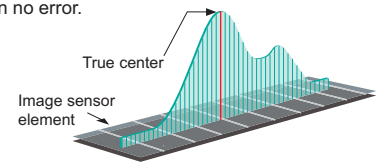

As the sensor measures the center of gravity of the entire light quantity distribution of the beam spot as position information, errors occur due to the presence of secondary reflected light.

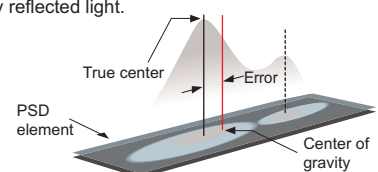

FDA regulations conforming types are available

FDA regulations conforming types, most suitable for equipment used in the USA, are available.

- FIBER SENSORS
- LASER SENSORS
- PHOTOELECTRIC SENSORS
- MICRO PHOTOELECTRIC SENSORS
- AREA SENSORS
- LIGHT CURTAINS / SAFETY COMPONENTS
- PRESSURE / FLOW SENSORS
- INDUCTIVE PROXIMITY SENSORS
- PARTICULAR USE SENSORS
- SENSOR OPTIONS
- SIMPLE WIRE- SAVING UNITS
- WIRE- SAVING SYSTEMS
- MEASUREMENT SENSORS
- STATIC ELECTRICITY PREVENTION DEVICES
- LASER MARKERS
- PLC
- HUMAN MACHINE INTERFACES
- ENERGY CONSUMPTION VISUALIZATION COMPONENTS
- FA COMPONENTS
- MACHINE VISION SYSTEMS
- UV CURING SYSTEMS

- Selection Guide
- Laser Displacement
- Magnetic Displacement
- Collimated Beam
- Digital Panel Controller
- Metal-sheet Double-feed Detection

- HL-G1
- HL-C2
- HL-C1

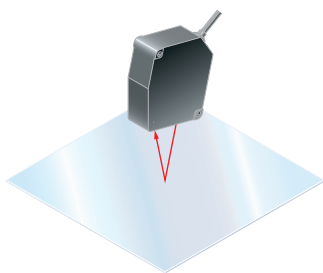
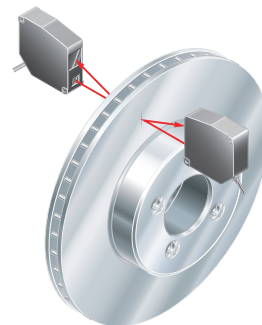
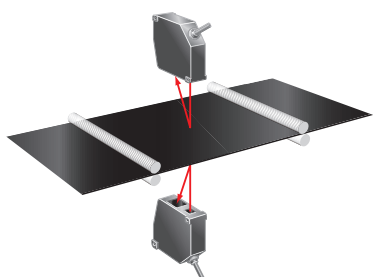
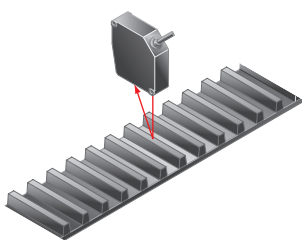
APPLICATIONS**Measuring glass substrate thickness****Detecting the grooves in aluminum wheel hubs****Measuring disk brake thickness****Measuring the thickness of rubber sheet****Measuring gap spacing in rubber belt material****Inspecting tire form****The long and wide range****Measures wide changes over long ranges**

The long and wide range capabilities over 350 mm ± 200 mm **13.780 in ± 7.874 in** allow large changes to be measured. Even if the object position changes, there is no need to change the sensor head settings or position.

High speed and high precision even over long and wide ranges with an ultra-small type head

High-speed and high-precision performance has been achieved in an ultra-small head of W26.6 × H82 × D87 mm **W1.047 × H3.228 × D3.425 in** with high-speed sampling of 100 μ s at a resolution of 10 μ m **0.394 mil**, and a linearity of ± 0.1 % F.S.

**Sensor heads HL-C135C-BK10
Controller HL-C1C-M-WL**



FIBER SENSORS

LASER SENSORS

PHOTOELECTRIC SENSORS

MICRO PHOTOELECTRIC SENSORS

AREA SENSORS

LIGHT CURTAINS / SAFETY COMPONENTS

PRESSURE / FLOW SENSORS

INDUCTIVE PROXIMITY SENSORS

PARTICULAR USE SENSORS

SENSOR OPTIONS

SIMPLE WIRE-SAVING UNITS

WIRE-SAVING SYSTEMS

MEASUREMENT SENSORS

STATIC ELECTRICITY PREVENTION DEVICES

LASER MARKERS

PLC

HUMAN MACHINE INTERFACES

ENERGY CONSUMPTION VISUALIZATION COMPONENTS

FA COMPONENTS

MACHINE VISION SYSTEMS

UV CURING SYSTEMS

Selection Guide

Laser Displacement

Magnetic Displacement

Collimated Beam

Digital Panel Controller

Metal-sheet Double-feed Detection

HL-G1**HL-C2****HL-C1**

- FIBER SENSORS
- LASER SENSORS
- PHOTOELECTRIC SENSORS
- MICRO PHOTOELECTRIC SENSORS
- AREA SENSORS
- LIGHT CURTAINS / SAFETY COMPONENTS
- PRESSURE / FLOW SENSORS
- INDUCTIVE PROXIMITY SENSORS
- PARTICULAR USE SENSORS
- SENSOR OPTIONS
- SIMPLE WIRE-SAVING UNITS
- WIRE-SAVING SYSTEMS
- MEASUREMENT SENSORS**
- STATIC ELECTRICITY PREVENTION DEVICES
- LASER MARKERS
- PLC
- HUMAN MACHINE INTERFACES
- ENERGY CONSUMPTION VISUALIZATION COMPONENTS
- FA COMPONENTS
- MACHINE VISION SYSTEMS
- UV CURING SYSTEMS

Equipped with serial input / output

An RS-232C interface for serial input and output is provided so that settings can be retrieved and saved. Measurement values can also be retrieved.

A convenient intelligent monitor (HL-C1AiM) is available (Optional)

An intelligent monitor is provided capable of the waveform display of each measurement condition setting and of measurement values as well as monitoring of measurement data and received light intensity data. It can perform waveform monitoring that was only possible until now with a conventional oscilloscope and can easily set each measurement condition and function with the aid of a PC.

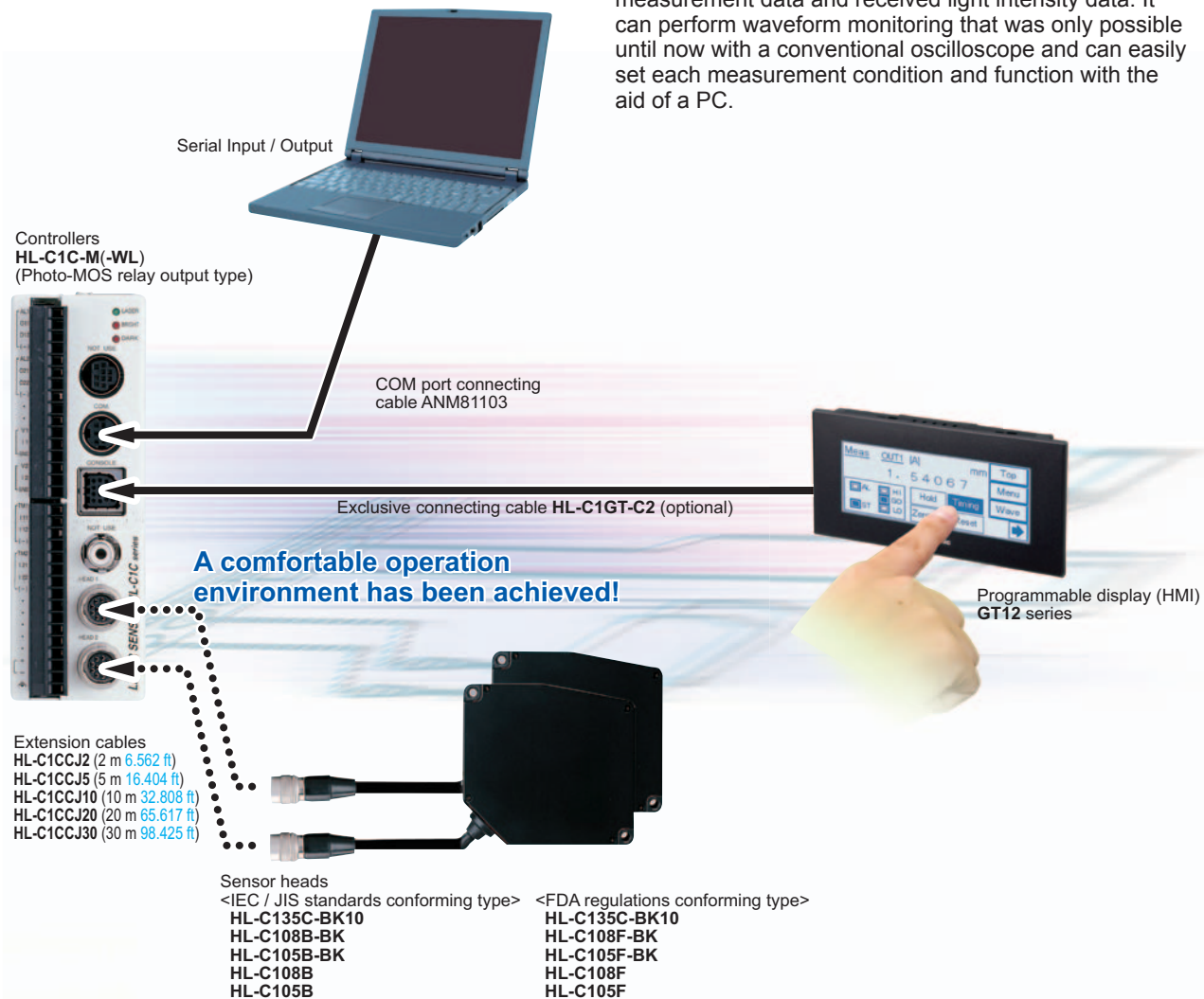

2 sensor heads can be connected! Reduces costs and saves space

The controller, to which 2 sensor heads can be connected, incorporates 2 separate input / output channels. This feature saves the expense and space usually required by a second controller, whenever 2 sensor heads are used.

Waterproof sensor head construction, compliant with IP67 rated protection

The **HL-C1** series can withstand water splashes.



Note: Accurate measurement cannot be performed if water is present on the sensing window of the sensor head itself.

Easy maintenance with sensor head compatibility

Maintainability has been significantly improved. Compatibility has been achieved through the incorporation of correction data into the sensor heads themselves. This sensor series no longer needs the amount of maintenance usually required for conventional displacement sensors of this class.

- Selection Guide
- Laser Displacement
- Magnetic Displacement
- Collimated Beam
- Digital Panel Controller
- Metal-sheet Double-feed Detection

- HL-G1
- HL-C2
- HL-C1**

Calculations can be performed when 2 sensor heads are used

The built-in calculation function allows measurement of gap and thicknesses without requiring a digital panel controller, thus saving further on costs and space.

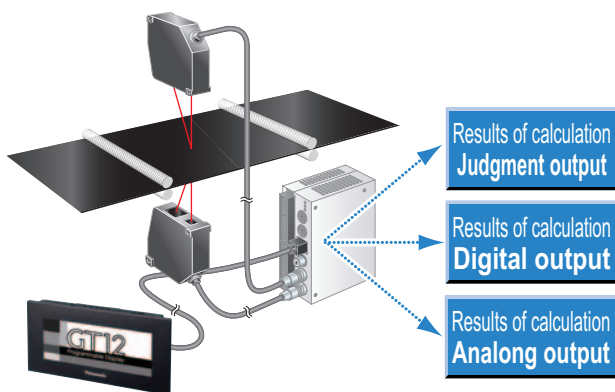

Compact controller and front connection reduce setup space

The ultra-compact controller **HL-C1C-M** with dimensions of W40 × H120 × D74 mm **W1.575 × H4.724 × D2.913 in** requires much less space for installation. Tight installation is also possible. Furthermore, the cables can be connected directly or to a removable terminal block, so that all connections come from the same direction in order to further save space.

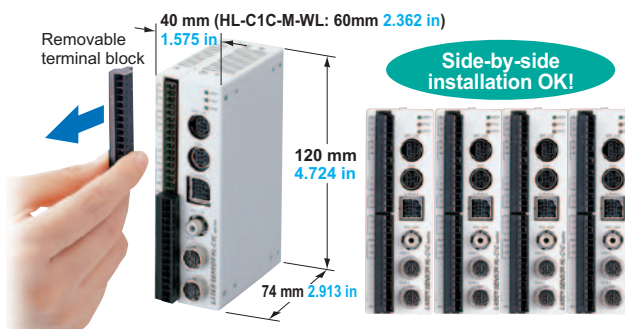

Enhanced functionality

The **HL-C1** series incorporates a great number of useful function, including hold function, calculation function, filter function and a hysteresis-setting function, which facilitate convenient usage in a variety of diverse applications.

Low-pass / High-pass filter functions

<Low-pass filter function>

For example, if the surface conditions of a metal object cause noise that interferes with accurate measurement, the use of the low-pass filter function will reduce the effects of noise and allow for the stable measurement of displacement.

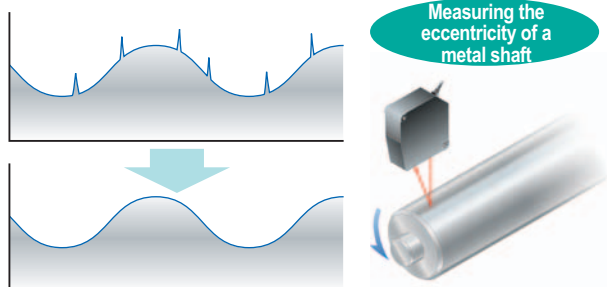

<High-pass filter function>

When measuring seams and gaps in objects that undergo large displacement changes due to vibration or tilting, such as measuring the eccentricity of a rotating object, this function will minimize the effects of these undulations and enable the accurate measurement of seams and gaps.

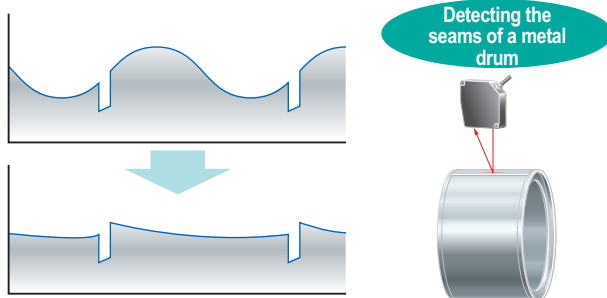

Analog output switching function during alarm output

During measurement, if the unit becomes incapable of performing measurements due to excessive or insufficient incident light intensity (during alarm output), this function allows the analog output to be switched to either hold the data obtained just previously, or to output a fixed value. If the fixed value is selected, one of two options can be chosen for the analog output during alarm output: the output of the maximum value (voltage output: +10.9 V, current output: 29.5 mA) or the output of the minimum value (voltage output: -10.9 V, current output: 0 mA).

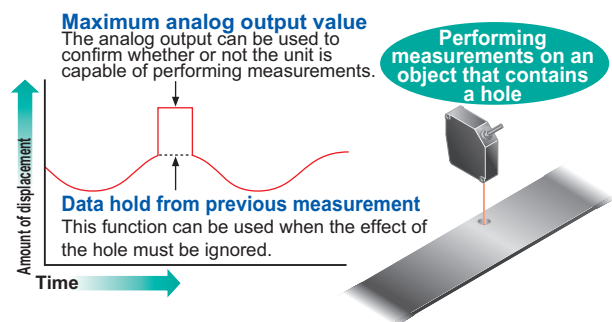

Hold functions

The **HL-C1** series incorporates 4 hold modes.

NORM (no hold)	This mode outputs the amount of displacement from the measurement center distance in real time. This mode is utilized for general-purpose operation.
P-P	This mode holds the output at the difference between the maximum and minimum measured values. This mode is utilized for vibration or eccentricity measurements.
PEAK	This mode holds the output at the maximum measured value.
VALLEY	This mode holds the output at the minimum measured value.

Data buffering function

It is possible to accumulate data up to 48,000 data into a controller temporarily in order to capture measurement data into a PC. All the accumulated data can be captured into the PC with **HL-C1AiM**. Used for reading and storing all data including the verification of measurement data when introduced as well as all post-measurement data.

- FIBER SENSORS
- LASER SENSORS
- PHOTOELECTRIC SENSORS
- MICRO PHOTOELECTRIC SENSORS
- AREA SENSORS
- LIGHT CURTAINS / SAFETY COMPONENTS
- PRESSURE / FLOW SENSORS
- INDUCTIVE PROXIMITY SENSORS
- PARTICULAR USE SENSORS
- SENSOR OPTIONS
- SIMPLE WIRE-SAVING UNITS
- WIRE-SAVING SYSTEMS

- MEASUREMENT SENSORS
- STATIC ELECTRICITY PREVENTION DEVICES
- LASER MARKERS
- PLC
- HUMAN MACHINE INTERFACES
- ENERGY CONSUMPTION VISUALIZATION COMPONENTS
- FA COMPONENTS
- MACHINE VISION SYSTEMS
- UV CURING SYSTEMS





- Selection Guide
- Laser Displacement
- Magnetic Displacement
- Collimated Beam
- Digital Panel Controller
- Metal-sheet Double-feed Detection

- HL-G1
- HL-C2
- HL-C1

FIBER SENSORS
LASER SENSORS
PHOTO-ELECTRIC SENSORS
MICRO PHOTO-ELECTRIC SENSORS
AREA SENSORS
LIGHT CURTAINS / SAFETY COMPONENTS
PRESSURE / FLOW SENSORS
INDUCTIVE PROXIMITY SENSORS
PARTICULAR USE SENSORS
SENSOR OPTIONS
SIMPLE WIRE-SAVING UNITS
WIRE-SAVING SYSTEMS
MEASURE-HEAT SENSORS
STATIC ELECTRICITY PREVENTION DEVICES
LASER MARKERS
PLC
HUMAN MACHINE INTERFACES
ENERGY CONSUMPTION VISUALIZATION COMPONENTS
FA COMPONENTS
MACHINE VISION SYSTEMS
UV CURING SYSTEMS
Selection Guide
Laser Displacement
Magnetic Displacement
Collimated Beam
Digital Panel Controller
Metal-sheet Double-feed Detection

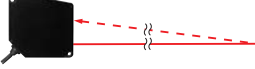
ORDER GUIDE



Sensor heads

Type	Appearance	Measurement center distance	Resolution (Note 1, 2)	Beam diameter	Model No.	Applicable controller	Conforming standards / regulations
Diffuse reflective type	Wide range	 350 mm 13.780 in (Measuring range ±200 mm 7.874 in)	10 μm 0.394 mil	400 × 200 μm 15.748 × 7.874 mil approx.	HL-C135C-BK10	HL-C1C-M-WL	IEC / JIS / FDA
	General purpose	 85 mm 3.346 in (Measuring range ±20 mm 0.787 in)	2 μm 0.079 mil	100 × 140 μm 3.937 × 5.512 mil approx.	HL-C108B-BK HL-C108F-BK		IEC / JIS FDA / IEC / JIS
High precision		 50 mm 1.969 in (Measuring range ±5 mm 0.197 in)	1 μm 0.039 mil	70 × 120 μm 2.756 × 4.724 mil approx.	HL-C105B-BK HL-C105F-BK	IEC / JIS FDA / IEC / JIS	
	Specular reflective type	General purpose	 81.4 mm 3.205 in (Measuring range ±16 mm 0.630 in)	2 μm 0.079 mil	100 × 140 μm 3.937 × 5.512 mil approx.	HL-C108B HL-C108F	HL-C1C-M
High precision		 46 mm 1.811 in (Measuring range ±4 mm 0.157 in)	1 μm 0.039 mil	70 × 120 μm 2.756 × 4.724 mil approx.	HL-C105B HL-C105F	IEC / JIS FDA / IEC / JIS	

Notes: 1) These values were obtained by converting P-P values into a distance. The P-P values indicate the distribution of measured values throughout the measurement center distance.



2) These values were obtained with an average number of samples: 256 (HL-C135C-BK10: 512), when using an object made of our company's standard white ceramic for measurement (an aluminum vapor deposition surface reflection mirror was used with specular reflective types).

Controllers

Type	Appearance	Model No.	Judgment outputs
Standard		HL-C1C-M	Photo-MOS relay
For HL-C135C-BK10		HL-C1C-M-WL	

Programmable display

It is possible to use the programmable display as an exclusive console which enables waveform display and condition setting by installing it in the screen data (free of charge) for HL-C1.

Designation	Appearance	Model No.	LCD	Power supply	Communication port	Color of front panel	SD memory card slot
GT12M		AIG12MQ02D	STN monochrome LCD (white / pink / red backlight)	24 V DC	RS-232C	Pure black	—
		AIG12MQ12D					○
		AIG12MQ03D				Hairline silver	—
		AIG12MQ13D					○
GT12G		AIG12GQ02D	STN monochrome (green / pink / red backlight)	24 V DC	RS-232C	Pure black	—
		AIG12GQ12D					○
		AIG12GQ03D				Hairline silver	—
		AIG12GQ13D					○

Notes: 1) The screen data differs depending on the language. Please download as necessary.



2) To install the screen data in the display, prepare a PC and a USB cable (A ⇄ mini-B connector type) separately.

3) The provided console screen data has no function to write the data into / download the data from SD memory card.

4) Please refer to our website for more details about programmable display **GT12**.

HL-G1
HL-C2
HL-C1

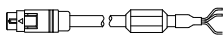
ORDER GUIDE**Options**

Designation	Appearance	Model No.	Description	
Sensor head extension cable		HL-C1CCJ2	Length: 2 m 6.562 ft , Net weight: 160 g approx.	Cabletyre cable with connector on both ends Cable outer diameter: \varnothing 7 mm \varnothing0.276 in Connector outer diameter: \varnothing 14.7 mm \varnothing0.579 in max.
		HL-C1CCJ5	Length: 5 m 16.404 ft , Net weight: 350 g approx.	
		HL-C1CCJ10	Length: 10 m 32.808 ft , Net weight: 700 g approx.	
		HL-C1CCJ20	Length: 20 m 65.617 ft , Net weight: 1,400 g approx.	
		HL-C1CCJ30	Length: 30 m 98.425 ft , Net weight: 2,000 g approx.	
GT series connector cable for HL-C1		HL-C1GT-C2	Length: 2 m 6.562 ft	Cable to connect the GT12 and HL-C1 series controller.
Intelligent monitor		HL-C1AIM	Enables the waveform display of each measurement condition setting and of measurement values as well as monitoring of measurement data and received light intensity data. 1pc. of COM port connection cable is attached.	

FIBER
SENSORSLASER
SENSORSPHOTO-
ELECTRIC
SENSORSMICRO
PHOTO-
ELECTRIC
SENSORSAREA
SENSORSLIGHT
CURTAINS /
SAFETY
COMPONENTSPRESSURE /
FLOW
SENSORSINDUCTIVE
PROXIMITY
SENSORSPARTICULAR
USE
SENSORSSENSOR
OPTIONSSIMPLE
WIRE-SAVING
UNITSWIRE-SAVING
SYSTEMSMEASURE-
MENT
SENSORSSTATIC
ELECTRICITY
PREVENTION
DEVICESLASER
MARKERS

PLC

HUMAN
MACHINE
INTERFACESENERGY
CONSUMPTION
VISUALIZATION
COMPONENTSFA
COMPONENTSMACHINE
VISION
SYSTEMSUV
CURING
SYSTEMSSelection
GuideLaser
DisplacementMagnetic
DisplacementCollimated
BeamDigital Panel
ControllerMetal-sheet
Double-feed
Detection**HL-G1****HL-C2****HL-C1**

SPECIFICATIONS

Sensor heads

Type	Diffuse reflective type		
	Wide range	General purpose	High precision
Item	Model No.	IEC / JIS standards conforming type	FDA regulations conforming type
		HL-C135C-BK10	HL-C108B-BK HL-C108F-BK
Measurement center distance	350 mm 13.780 in	85 mm 3.346 in	50 mm 1.969 in
Measuring range	±200 mm 7.874 in	±20 mm ±0.787 in	±5 mm ±0.197 in
Resolution (Note 2, 3)	10 μm 0.394 mil	2 μm 0.079 mil	1 μm 0.039 mil
Linearity (Note 4)	±0.1 % F.S.		
Temperature characteristics	0.02 % F.S./°C		
Laser emission indicator	Green LED (lights up during laser emission or immediately before laser emission)		
Measuring range indicator	Yellow LED (blinks within the measuring range and lights up when near the measurement center distance)		
Environmental resistance	Pollution degree	3 (Industrial environment)	
	Protection	IP67 (IEC)(excluding the connector)	
	Ambient temperature	0 to +45 °C +32 to +113 °F (No dew condensation), Storage: -20 to +70 °C -4 to +158 °F	
	Ambient humidity	35 to 85 % RH, Storage: 35 to 85 % RH	
	Ambient illuminance	Incandescent light: 3,000 lx at the light-receiving face	
	Vibration resistance	10 to 55 Hz (period: 1 min.) frequency, 1.5 mm 0.059 in amplitude in X, Y and Z directions for two hours each	
	Shock resistance	196 m/s ² acceleration (20 G approx.) in X, Y and Z directions for three times each	
Emitting element	Red semiconductor laser, Class 3B (Class IIIb for FDA regulations) (Max. output: 10 mW, Peak emission wavelength: 658 nm 0.026 mil)	Red semiconductor laser, Class 2 (Class II for FDA regulations) (IEC / JIS standards conforming type: IEC / JIS, FDA regulations conforming type: FDA / IEC / JIS) (Max. output: 1 mW, Peak emission wavelength: 658 nm 0.026 mil)	
Beam diameter (Note 5)	400 × 200 μm 15.748 × 7.874 mil approx.	100 × 140 μm 3.937 × 5.512 mil approx.	70 × 120 μm 2.756 × 4.724 mil approx.
Receiving element	Linear image sensor		
Enclosure earthing	Floating		
Material	Enclosure: Die-cast aluminum, Case cover: Die-cast aluminum, Front cover: Glass		
Cable	Cabletyre cable, 0.5 m 1.640 ft long with connector		
Cable extension	Extension up to total 30 m 98.425 ft is possible, with optional cable.		
Weight	Net weight: 300 g approx.		
Accessory	Warning label • JIS (written in Japanese): 1 set (for FDA conforming type only) • IEC (written in English) / GB (written in Chinese): 1 set each		

- Notes: 1) Where measurement conditions have not been specified precisely, the conditions used were as follows: supply voltage 24 V DC, ambient temperature +20 °C **+68 °F**, sampling rate 100 μs, average number of samples: 256 (**HL-C135C-BK10**: 512), object measured at measurement center distance is made of white ceramic (an aluminum vapor deposition surface reflection mirror was used with specular reflective type). Linearity also depends upon the characteristics of the object being measured.
- 2) These values were obtained by converting P-P values into a distance. The P-P values indicate the distribution of measured values throughout the measurement center distance.
- 3) These values were obtained with an average number of samples: 256 (**HL-C135C-BK10**: 512), when using an object made of our company's standard white ceramic for measurement (an aluminum vapor deposition surface reflection mirror was used with specular reflective types).
- 4) This value indicates the range of errors for an ideal linear displacement output, when using an object made of our company's standard white ceramic for measurement (an aluminum vapor deposition surface reflection mirror was used with specular reflective types). This value may fluctuate depending on the characteristics of the object measured.
- 5) These values were defined by using $1/e^2$ (13.5 %) of the center light intensity. If there is a slight leakage of light outside the normal spot diameter and if the periphery surrounding the sensing point has a higher reflectivity than the sensing point itself, then the results may be affected.

Selection Guide

Laser Displacement

Magnetic Displacement

Collimated Beam

Digital Panel Controller

Metal-sheet Double-feed Detection

HL-G1

HL-C2

HL-C1

SPECIFICATIONS**Sensor heads**

Item	Model No.	Type	Specular reflective type	
			General purpose	High precision
			IEC / JIS standards conforming type	FDA regulations conforming type
			HL-C108B	HL-C105B
			HL-C108F	HL-C105F
Measurement center distance			81.4 mm 3.205 in	46 mm 1.811 in
Measuring range			±16 mm ±0.630 in	±4 mm ±0.157 in
Resolution (Note 2, 3)			2 μm 0.079 mil	1 μm 0.039 mil
Linearity (Note 4)			±0.1 % F.S.	
Temperature characteristics			0.02 % F.S./°C	
Laser emission indicator			Green LED (lights up during laser emission or immediately before laser emission)	
Measuring range indicator			Yellow LED (blinks within the measuring range and lights up when near the measurement center distance)	
Environmental resistance	Pollution degree		3 (Industrial environment)	
	Protection		IP67 (IEC) (excluding the connector)	
	Ambient temperature		0 to +45 °C +32 to +113 °F (No dew condensation), Storage: -20 to +70 °C -4 to +158 °F	
	Ambient humidity		35 to 85 % RH, Storage: 35 to 85 % RH	
	Ambient illuminance		Incandescent light: 3,000 lx at the light-receiving face	
	Vibration resistance		10 to 55 Hz (period: 1 min.) frequency, 1.5 mm 0.059 in amplitude in X,Y and Z directions for two hours each	
	Shock resistance		196 m/s ² acceleration (20 G approx.) in X,Y and Z directions for three times each	
Emitting element			Red semiconductor laser, Class 2 (Class II for FDA regulations) (IEC / JIS standards conforming type: IEC / JIS, FDA regulations conforming type: FDA / IEC / JIS) (Max. output: 1 mW, Peak emission wavelength: 658 nm 0.026 mil)	
Beam diameter (Note 5)			100 × 140 μm 3.937 × 5.512 mil approx.	70 × 120 μm 2.756 × 4.724 mil approx.
Receiving element			Linear image sensor	
Enclosure earthing			Floating	
Material			Enclosure: Die-cast aluminum, Case cover: Die-cast aluminum, Front cover: Glass	
Cable			Cabletyre cable, 0.5 m 1.640 ft long with connector	
Cable extension			Extension up to total 30 m 98.425 ft is possible, with optional cable.	
Weight			Net weight: 300 g approx.	
Accessory			Warning label • JIS (written in Japanese): 1 set (for FDA conforming type only) • IEC (written in English) / GB (written in Chinese): 1 set each	

Notes: 1) Where measurement conditions have not been specified precisely, the conditions used were as follows: supply voltage 24 V DC, ambient temperature +20 °C **+68 °F**, sampling rate 100 μs, average number of samples: 256, object measured at measurement center distance is made of white ceramic (an aluminum vapor deposition surface reflection mirror was used with specular reflective type). Linearity also depends upon the characteristics of the object being measured.

- These values were obtained by converting P-P values into a distance. The P-P values indicate the distribution of measured values throughout the measurement center distance.
- These values were obtained with an average number of samples: 256, when using an object made of our company's standard white ceramic for measurement (an aluminum vapor deposition surface reflection mirror was used with specular reflective types).
- This value indicates the range of errors for an ideal linear displacement output, when using an object made of our company's standard white ceramic for measurement (an aluminum vapor deposition surface reflection mirror was used with specular reflective types). This value may fluctuate depending on the characteristics of the object measured.
- These values were defined by using 1/e² (13.5 %) of the center light intensity. If there is a slight leakage of light outside the normal spot diameter and if the periphery surrounding the sensing point has a higher reflectivity than the sensing point itself, then the results may be affected.

FIBER SENSORS

LASER SENSORS

PHOTO-ELECTRIC SENSORS

MICRO PHOTO-ELECTRIC SENSORS

AREA SENSORS

LIGHT CURTAINS / SAFETY COMPONENTS

PRESSURE / FLOW SENSORS

INDUCTIVE PROXIMITY SENSORS

PARTICULAR USE SENSORS

SENSOR OPTIONS

SIMPLE WIRE-SAVING UNITS

WIRE-SAVING SYSTEMS

MEASUREMENT SENSORS

STATIC ELECTRICITY PREVENTION DEVICES

LASER MARKERS

PLC

HUMAN MACHINE INTERFACES

ENERGY CONSUMPTION VISUALIZATION COMPONENTS

FA COMPONENTS

MACHINE VISION SYSTEMS

UV CURING SYSTEMS

Selection Guide

Laser Displacement

Magnetic Displacement

Collimated Beam

Digital Panel Controller

Metal-sheet Double-feed Detection

HL-G1**HL-C2****HL-C1**

SPECIFICATIONS

Controllers

Item	Model No.	Photo-MOS relay output	
		Standard	For HL-C135C-BK10
		HL-C1C-M	HL-C1C-M-WL
Connection sensor heads		Maximum 2 sensor heads	
Supply voltage		24 V DC $\pm 10\%$ including ripple 0.5 V (P-P)	
Current consumption		When 1 sensor is connected: 430 mA approx., When 2 sensors are connected: 550 mA approx.	
Sampling rate		Selectable from 100 μ s / 144 μ s / 200 μ s / 255 μ s / 332 μ s / 498 μ s / 1,000 μ s	
Temperature characteristics		$\pm 0.01\%$ F.S./ $^{\circ}$ C	
Analog output	Voltage	Output voltage: ± 5 V/F.S. [default setting when diffuse reflective mode is selected (Note 2)] Output range: -10.9 to $+10.9$ V Output current: Max. 2 mA, Output impedance: 50 Ω	
	Current (Note 3)	Output current: 4 to 20 mA/F.S. [default setting when diffuse reflective mode is selected (Note 4)] Output range: 0 to 29.5 mA (maximum of 25 mA at max. load impedance) Load impedance: 250 Ω or less	
Alarm output		Photo-MOS relay • Maximum load current: 50 mA • Applied voltage: 30 V DC or less (between alarm output and COM) • ON impedance: 35 Ω or less • Operation time: Max. 2 ms	
Output operation		Opened when the amount of light is excessive or insufficient.	
Short-circuit protection		Incorporated	
Judgment outputs (O1, O2)		Photo-MOS relay • Maximum load current: 50 mA • Applied voltage: 30 V DC or less (between judgment output and COM) • ON impedance: 35 Ω or less • Operation time: Max. 2 ms	
Utilization category		DC-12 or DC-13	
Output operation		Opened or closed when the threshold value is reached. Determined based on judgment output mode selection. (The threshold value varies with the hysteresis setting.)	
Short-circuit protection		Incorporated	
Serial input / output		RS-232C	
Timing input (Laser emission)		Laser emission stops or continues when voltage (using input voltage: 12 to 24 V DC, maximum input voltage: 30 V DC) is input or there is an open circuit: determined based on input mode selection.	
Remote interlock input		Laser emission stop when open circuit	
Zero set ON input		Zero set: ON when voltage (using input voltage: 12 to 24 V DC, maximum input voltage: 30 V DC) is input	
Zero set OFF input		Zero set: OFF when voltage (using input voltage: 12 to 24 V DC, maximum input voltage: 30 V DC) is input	
Indicators	Laser emission	Green LED (lights up during laser emission from sensor head 1 or sensor head 2, or immediately before laser emission)	
	BRIGHT	Red LED (lights up upon disabled measurement due to excessive light at sensor head 1 or 2)	
	DARK	Red LED (lights up upon disabled measurement due to insufficient light at sensor head 1 or 2)	
Setting / Data display		Compact console (optional)	
Calibration (Note 5)	Shift	± 20.0000 mm ± 0.787 in	± 200.0000 mm ± 7.874 in
	Span	0.9000 to 1.1000	
Average number of samples (Note 5)		OFF, 2 to 32,768 times (16 steps)	
Digital filters (Note 5)		High pass: OFF, 10 to 2,000 Hz (9 steps), Low pass: OFF, 10 to 2,000 Hz (9 steps)	
Calculation functions (Note 5)		L \pm KA, L \pm KB, L \pm K (A \pm B) A, B: Sensor head 1, Sensor head 2 measurement values, L = ± 999.9999 , K = 0.0001 to 99.9999	
Hold functions (Note 5)		Selectable from NORMAL / P-P / PEAK / VALLEY	
Environmental resistance	Pollution degree	3 (Industrial environment)	
	Ambient temperature	0 to $+50$ $^{\circ}$ C $+32$ to $+122$ $^{\circ}$ F (No dew condensation), Storage: -20 to $+70$ $^{\circ}$ C -4 to $+158$ $^{\circ}$ F	
	Ambient humidity	35 to 85 % RH, Storage: 35 to 85 % RH	
	Vibration resistance	10 to 55 Hz frequency (period: 1 min.) 0.75 mm 0.030 in amplitude in X, Y and Z directions for 30 min. each	
	Shock resistance	196 m/s ² (20 G approx.) in X, Y and Z directions for 3 times each	
Cable length		Power line: Less than 10 m 32.808 ft, Signal line: Less than 30 m 98.425 ft	
Weight		Net weight: 300 g approx.	
Accessory		Key: 2 pcs.	

- Notes: 1) Where measurement conditions have not been specified precisely, the conditions used were as follows: supply voltage 24 V DC, ambient temperature $+20$ $^{\circ}$ C $+68$ $^{\circ}$ F, sampling rate 100 μ s, average number of samples: 256 (HL-C1C-M-WL: 512), and measurement center distance.
 2) If specular reflective mode is selected, then the default setting is ± 4 V/F.S.
 3) The maximum analog output current will vary with load impedance.
 4) If specular reflective mode is selected, then the default setting is 5.6 to 18.4 mA/F.S.
 5) These values can be set using the command input from external equipment via the compact console and RS-232C interface.

I/O CIRCUIT AND WIRING DIAGRAMS

HL-C1C-M(-WL) Controller

Input circuit diagram

Connection example 1 (NPN)

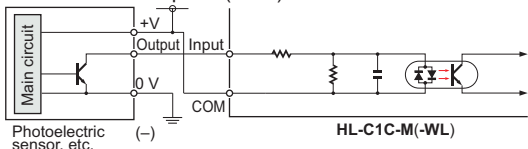

Connection example 2 (PNP)

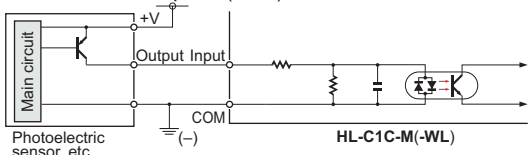

Output circuit diagram

Alarm output, Judgment output

Connection example 1 (NPN)

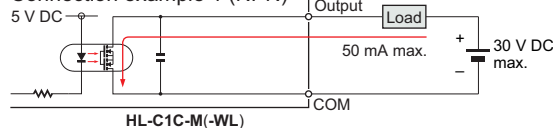

Connection example 2 (PNP)

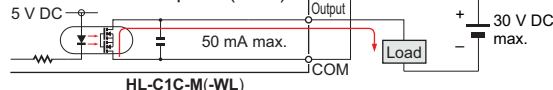

Analog output diagram

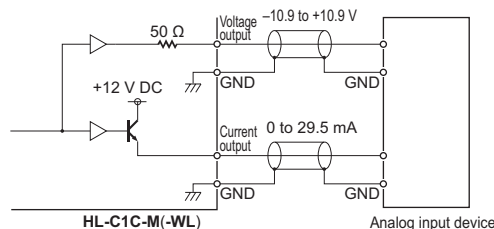

Notes: 1) Do not short-circuit analog output terminals or apply voltage to them.
2) Use shielded wires for analog outputs.

Terminal arrangement

Input terminals

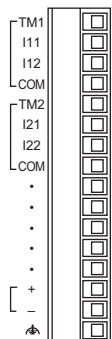

Symbol	Description
TM1 (Note 1)	Timing input (sensor head 1) (Note 1)
I11	Zero set ON input (sensor head 1)
I12	Zero set OFF input (sensor head 1)
COM	Input common
TM2 (Note 2)	Timing input (sensor head 2) (Note 2)
I21	Zero set ON input (sensor head 2)
I22	Zero set OFF input (sensor head 2)
COM	Input common
•	Not used
•	Not used
•	Not used
•	Not used
+	24 V DC input for power supply
-	Power supply ground
⏏	Function ground

Output terminals

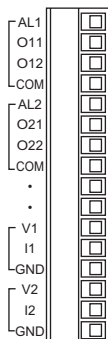

Symbol	Description
AL1	Alarm output (sensor head 1)
O11	Judgment output 1 (sensor head 1)
O12	Judgment output 2 (sensor head 1)
COM	Output common
AL2	Alarm output (sensor head 2)
O21	Judgment output 1 (sensor head 2)
O22	Judgment output 2 (sensor head 2)
COM	Output common
•	Not used
•	Not used
V1	Analog voltage output (sensor head 1)
I1	Analog current output (sensor head 1)
GND	Analog output ground
V2	Analog voltage output (sensor head 2)
I2	Analog current output (sensor head 2)
GND	Analog output ground

Notes: 1) In the case of **HL-C1C-M-WL**, "IL1: Remote interlock input (sensor head 1)"
2) In the case of **HL-C1C-M-WL**, "IL2: Remote interlock input (sensor head 2)"
3) Terminals marked with "•" are not used. Some are connected to internal circuitry and cannot be used as relay terminals in wiring, etc.

SENSING CHARACTERISTICS (TYPICAL)

HL-C135C-BK10 Diffuse reflective type

Correlation between measuring distance and error characteristics

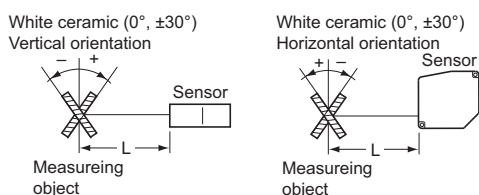

Vertical positioning

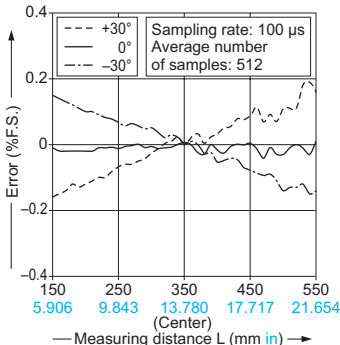

Horizontal positioning

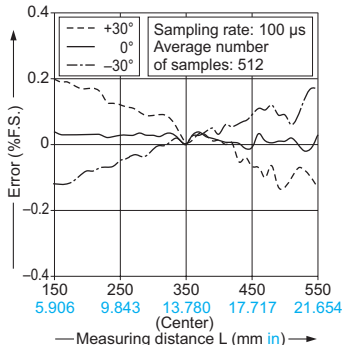

FIBER SENSORS
LASER SENSORS
PHOTO-ELECTRIC SENSORS
MICRO PHOTO-ELECTRIC SENSORS
AREA SENSORS
LIGHT CURTAINS / SAFETY COMPONENTS
PRESSURE / FLOW SENSORS
INDUCTIVE PROXIMITY SENSORS
PARTICULAR USE SENSORS
SENSOR OPTIONS
SIMPLE WIRE-SAVING UNITS
WIRE-SAVING SYSTEMS
MEASURE-MENT SENSORS
STATIC ELECTRICITY PREVENTION DEVICES
LASER MARKERS
PLC
HUMAN MACHINE INTERFACES
ENERGY CONSUMPTION VISUALIZATION COMPONENTS
FA COMPONENTS
MACHINE VISION SYSTEMS
UV CURING SYSTEMS
Selection Guide
Laser Displacement
Magnetic Displacement
Collimated Beam
Digital Panel Controller
Metal-sheet Double-feed Detection

HL-G1

HL-C2

HL-C1

SENSING CHARACTERISTICS (TYPICAL)

FIBER SENSORS
LASER SENSORS
PHOTO-ELECTRIC SENSORS
MICRO PHOTO-ELECTRIC SENSORS
AREA SENSORS
LIGHT CURTAINS / SAFETY COMPONENTS
PRESSURE / FLOW SENSORS
INDUCTIVE PROXIMITY SENSORS
PARTICULAR USE SENSORS
SENSOR OPTIONS
SIMPLE WIRE-SAVING UNITS
WIRE-SAVING SYSTEMS
MEASURE-HEAT SENSORS
STATIC ELECTRICITY PREVENTION DEVICES
LASER MARKERS
PLC
HUMAN MACHINE INTERFACES
ENERGY CONSUMPTION VISUALIZATION COMPONENTS
FA COMPONENTS
MACHINE VISION SYSTEMS
UV CURING SYSTEMS
Selection Guide
Laser Displacement
Magnetic Displacement
Collimated Beam
Digital Panel Controller
Metal-sheet Double-feed Detection

HL-C108□-BK

Diffuse reflective type

Correlation between measuring distance and error characteristics

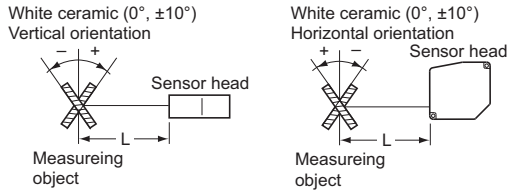

Vertical positioning

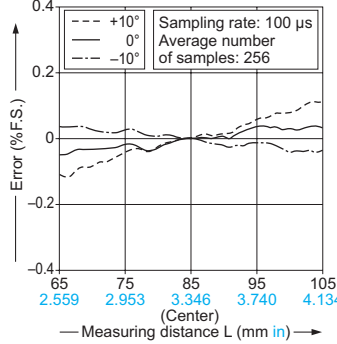

Horizontal positioning

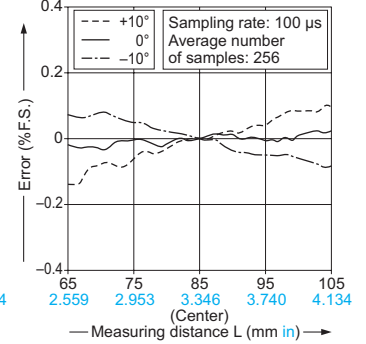

HL-C105□-BK

Diffuse reflective type

Correlation between measuring distance and error characteristics

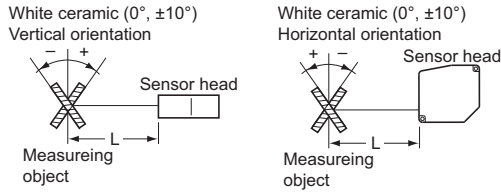

Vertical positioning

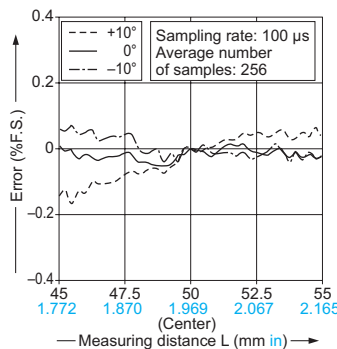

Horizontal positioning

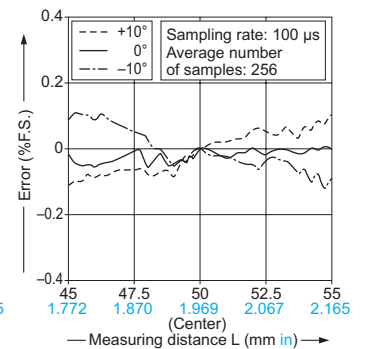

HL-C108B HL-C108F

Specular reflective type

Correlation between measuring distance and error characteristics

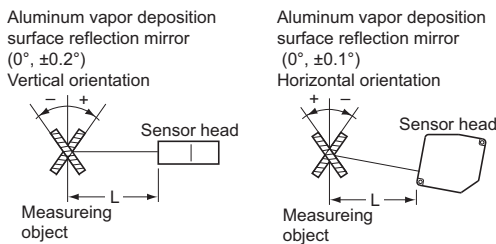

Vertical positioning

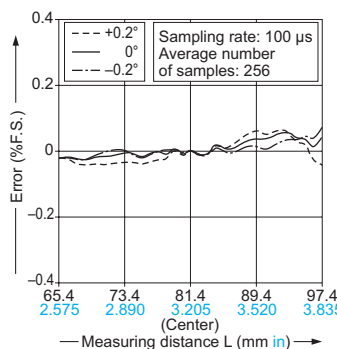

Horizontal positioning

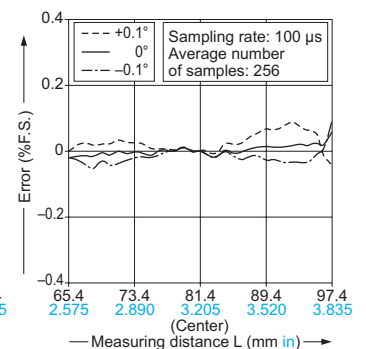

HL-C105B HL-C105F

Specular reflective type

Correlation between measuring distance and error characteristics

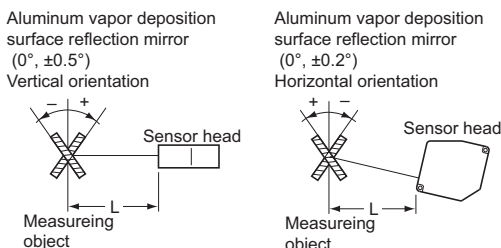

Vertical positioning

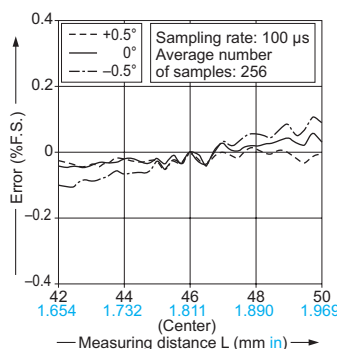

Horizontal positioning

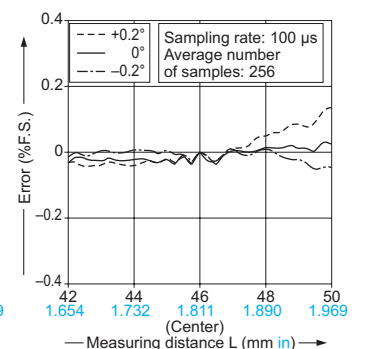

HL-G1

HL-C2

HL-C1

PRECAUTIONS FOR PROPER USE

Refer to p.1501 for general precautions and p.1499~ for information about laser beam.

- This catalog is a guide to select a suitable product. Be sure to read instruction manual attached to the product prior to its use.



- Never use this product as a sensing device for personnel protection.
- In case of using sensing devices for personnel protection, use products which meet laws and standards, such as OSHA, ANSI or IEC etc., for personnel protection applicable in each region or country.

HL-C108 □
HL-C105 □

- This product is classified as a Class 2 Laser Product in IEC / JIS standards and a Class II Laser Product in FDA regulations 21 CFR 1040.10. Do not look at the laser beam directly or through optical system such as a lens.
- The following label is attached to the product. Handle the product according to the instruction given on the warning label.

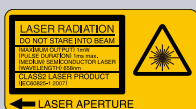

(The English warning label based on FDA regulations is pasted on the FDA regulations conforming type.)

HL-C135C-BK10

- This product is classified as a Class 3B Laser Product in IEC / JIS standards and a Class IIIb Laser Product in FDA regulations 21 CFR 1040.10. Never look at or touch the direct laser beam and its reflection.
- The following label is attached to the product. Handle the product according to the instruction given on the warning label.



(The English warning label based on FDA regulations is pasted on the FDA regulations conforming type.)

To comply with the European EMC Directive (HL-C1C-M-WL)

- To comply with the European EMC Directive, install a ferrite core on wires to the terminal block as shown below.

Recommended ferrite core:
E04RC281613 manufactured by Seiwa Electric Mfg. Co., Ltd. or equivalent
TFT-152613N manufactured by Takeuchi Industry Co.,Ltd. or equivalent

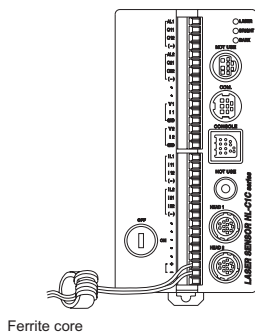

Ferrite core

Sensor head mounting direction

- To obtain the greatest precision, the sensor head should be oriented facing the direction of movement of the object's surface, as shown in the figure below.

Rotating object

<Correct>

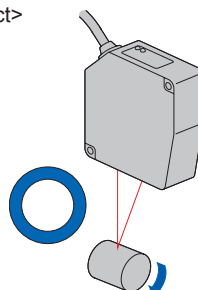

<Incorrect>

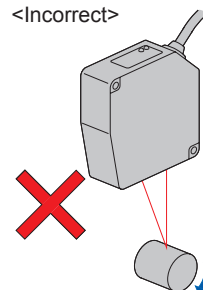
**Object that has large differences in gaps, grooves and colors**

<Correct>

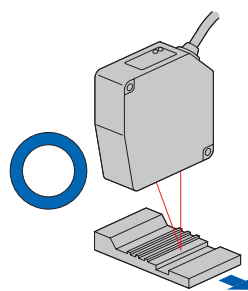

<Incorrect>

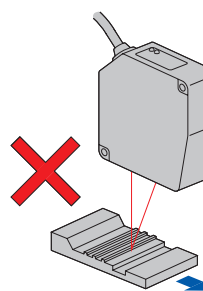
**Safety standards for laser beam products**

- A laser beam can harm human being's eyes, skin, etc., because of its high energy density. IEC and JIS have classified laser products according to the degree of hazard and the stipulated safety requirements.
HL-C108 □ and **HL-C105** □: Classified as Class 2 laser products
HL-C135C-BK10: Classified as a Class 3B laser products
(Refer to p.1499~ for information about laser beam.)

Safe use of laser products

- For the purpose of preventing users from suffering injuries by laser products, IEC 60825-1(Safety of laser products). Kindly check the standards before use.
(Refer to p.1499~ for information about laser beam.)

FIBER

SENSORS

LASER

SENSORS

PHOTO-

ELECTRIC

SENSORS

MICRO

PHOTO-

ELECTRIC

SENSORS

AREA

SENSORS

LIGHT

CURTAINS /

SAFETY

COMPONENTS

PRESSURE /

FLOW

SENSORS

INDUCTIVE

PROXIMITY

SENSORS

PARTICULAR

USE

SENSORS

SENSOR

OPTIONS

SIMPLE

WIRE-SAVING

UNITS

WIRE-SAVING

SYSTEMS

MEASURE-

MENT

SENSORS

STATIC

ELECTRICITY

PREVENTION

DEVICES

LASER

MARKERS

PLC

HUMAN

MACHINE

INTERFACES

ENERGY

CONSUMPTION

VISUALIZATION

COMPONENTS

FA

COMPONENTS

MACHINE

VISION

SYSTEMS

UV

CURING

SYSTEMS

Selection

Guide

Laser

Displacement

Magnetic

Displacement

Collimated

Beam

Digital Panel

Controller

Metal-sheet

Double-feed

Detection

HL-G1**HL-C2****HL-C1**

PRECAUTIONS FOR PROPER USE

Refer to p.1501 for general precautions and p.1499~ for information about laser beam.

Mutual interference

- When installing 2 or more sensor heads side by side, mutual interference will not occur if the laser spots from other sensor heads do not fall within the shaded areas of the sensor head in the figure below. Multiple sensor heads must be installed in a manner such that laser spots from other sensor heads will be prevented from falling within these shaded areas. When two sensor heads are connected to a controller and used, the measures described below are not required since the mutual interference prevention function can be used.

HL-C108

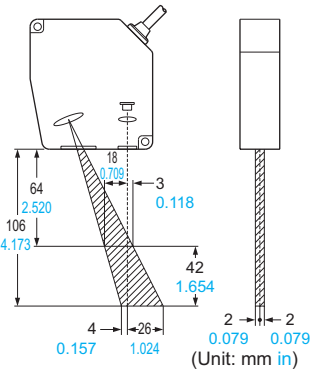

HL-C105

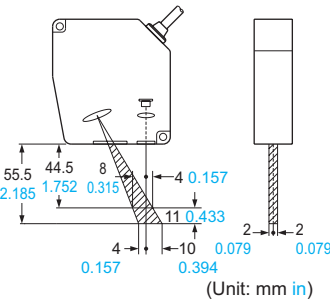

HL-C135C-BK10

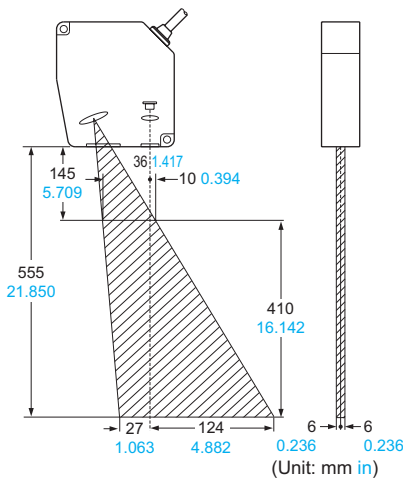

DIMENSIONS (Unit: mm in)

The CAD data in the dimensions can be downloaded from our website.

HL-C108-BK

Sensor head

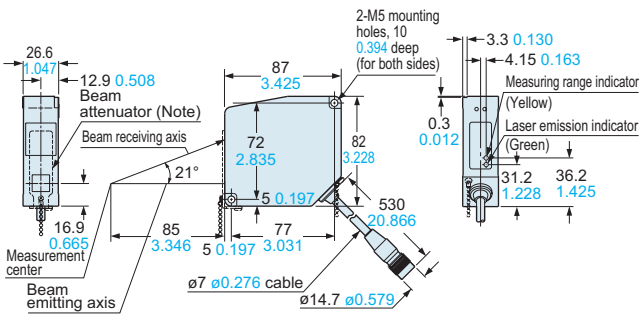

Note: There is not beam attenuator on IEC / JIS standards conforming type.

HL-C108B HL-C108F

Sensor head

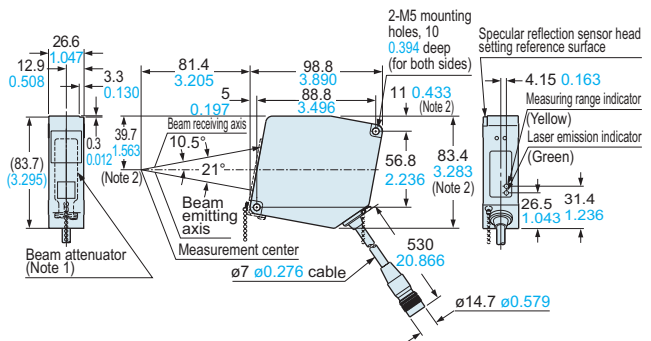

Notes: 1) There is not beam attenuator on IEC / JIS standards conforming type.
2) Figure shows standard installation level dimensions.

HL-C105-BK

Sensor head

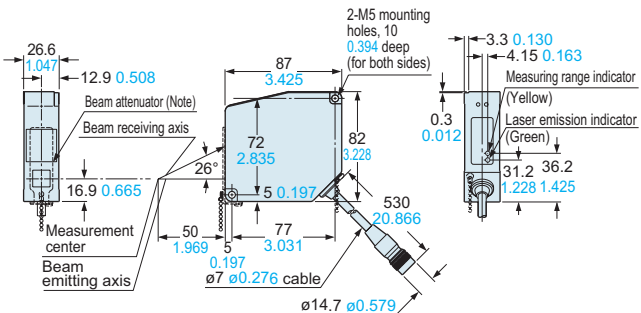

Note: There is not beam attenuator on IEC / JIS standards conforming type.

HL-C105B HL-C105F

Sensor head

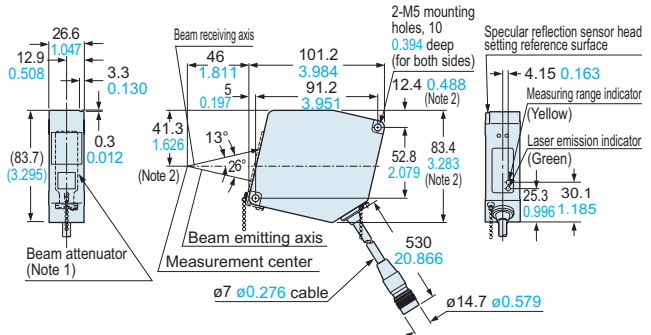

Notes: 1) There is not beam attenuator on IEC / JIS standards conforming type.
2) Figure shows standard installation level dimensions.

HL-G1

HL-C2

HL-C1

Selection Guide
Laser Displacement
Magnetic Displacement
Collimated Beam
Digital Panel Controller
Metal-sheet Double-feed Detection

FA COMPONENTS
MACHINE VISION SYSTEMS
UV CURING SYSTEMS

HUMAN MACHINE INTERFACES
ENERGY CONSUMPTION VISUALIZATION COMPONENTS

LASER MARKERS

MEASURE-MENT SENSORS

WIRE-SAVING SYSTEMS

SIMPLE WIRE-SAVING UNITS

SENSOR OPTIONS

PARTICULAR USE SENSORS

INDUCTIVE PROXIMITY SENSORS

PRESSURE / FLOW SENSORS

PHOTO-ELECTRIC SENSORS

AREA SENSORS

MICRO PHOTO-ELECTRIC SENSORS

PHOTO-ELECTRIC SENSORS

LASER SENSORS

FIBER SENSORS

DIMENSIONS (Unit: mm in)

The CAD data in the dimensions can be downloaded from our website.

HL-C135C-BK10 Sensor head

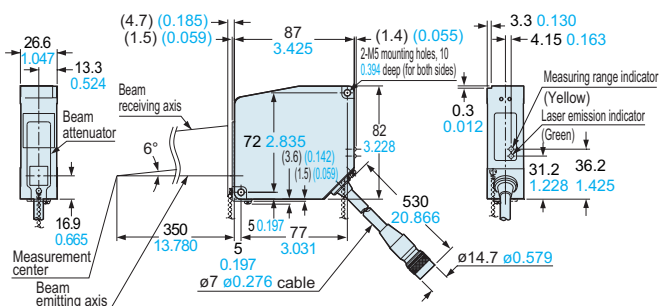

HL-C1C-M Controller

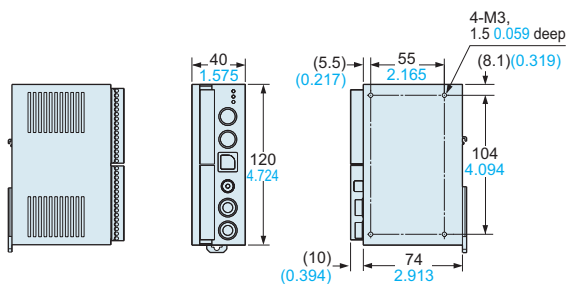

HL-C1C-M-WL Controller

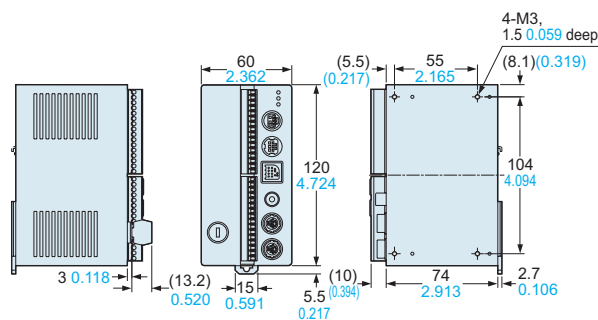

HL-C1CCJ□ Extension cable

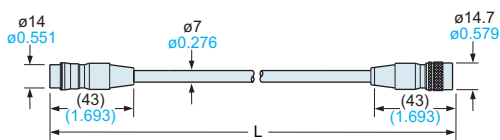

• Length L

Model No.	Length L
HL-C1CCJ2	2,000 78.740
HL-C1CCJ5	5,000 196.850
HL-C1CCJ10	10,000 393.700
HL-C1CCJ20	20,000 787.400
HL-C1CCJ30	30,000 1181.100

FIBER SENSORS

LASER SENSORS

PHOTO-ELECTRIC SENSORS

MICRO PHOTO-ELECTRIC SENSORS

AREA SENSORS

LIGHT CURTAINS / SAFETY COMPONENTS

PRESSURE / FLOW SENSORS

INDUCTIVE PROXIMITY SENSORS

PARTICULAR USE SENSORS

SENSOR OPTIONS

SIMPLE WIRE-SAVING UNITS

WIRE-SAVING SYSTEMS

MEASUREMENT SENSORS

STATIC ELECTRICITY PREVENTION DEVICES

LASER MARKERS

PLC

HUMAN MACHINE INTERFACES

ENERGY CONSUMPTION VISUALIZATION COMPONENTS

FA COMPONENTS

MACHINE VISION SYSTEMS

UV CURING SYSTEMS

Selection Guide

Laser Displacement

Magnetic Displacement

Collimated Beam

Digital Panel Controller

Metal-sheet Double-feed Detection

HL-G1

HL-C2

HL-C1