



Chipsmall Limited consists of a professional team with an average of over 10 year of expertise in the distribution of electronic components. Based in Hongkong, we have already established firm and mutual-benefit business relationships with customers from,Europe,America and south Asia,supplying obsolete and hard-to-find components to meet their specific needs.

With the principle of “Quality Parts,Customers Priority,Honest Operation,and Considerate Service”,our business mainly focus on the distribution of electronic components. Line cards we deal with include Microchip,ALPS,ROHM,Xilinx,Pulse,ON,Everlight and Freescale. Main products comprise IC,Modules,Potentiometer,IC Socket,Relay,Connector.Our parts cover such applications as commercial,industrial, and automotives areas.

We are looking forward to setting up business relationship with you and hope to provide you with the best service and solution. Let us make a better world for our industry!



Contact us

Tel: +86-755-8981 8866 Fax: +86-755-8427 6832

Email & Skype: info@chipsmall.com Web: www.chipsmall.com

Address: A1208, Overseas Decoration Building, #122 Zhenhua RD., Futian, Shenzhen, China



DIALIGHT PART NUMBER	OPERATING CHARACTERISTICS @ T _A = 25°C								
	COLOR	VIEWING ANGLE	FORWARD VOLTAGE (V)		REVERSE VOLTAGE	PEAK WAVELENGTH (nm)	LUMINOUS INTENSITY (mcd)		TEST CONDITIONS
			TYP	MAX		TYP	MIN	TYP	
HLMP-K101-104	AlGaAs RED	60°	1.8	2.2	5 V @ I _R = 100 μA	645	22	45	I _F = 20 mA
HLMP-K150-104	AlGaAs RED		1.6	1.8			1.3	2.0	I _F = 1 mA

REV.	ECN NO.	REVISIONS	DRN.	CKD.	APP.	DATE
A	—	NEW RELEASE	M.C.			

MAXIMUM RATINGS		
	HLMP-K101-104	HLMP-K150-104
D.C. FORWARD CURRENT	30 mA	30 mA
OPERATING TEMPERATURE	-20°C TO +100°C	-20°C TO +100°C
STORAGE TEMPERATURE	-55°C TO +100°C	-55°C TO +100°C
LEAD SOLDERING TEMPERATURE	260°C FOR 5 SEC.	260°C FOR 5 SEC.

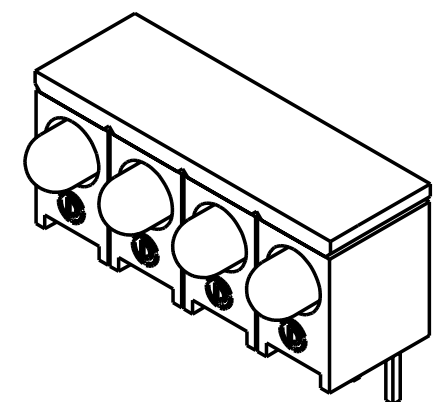
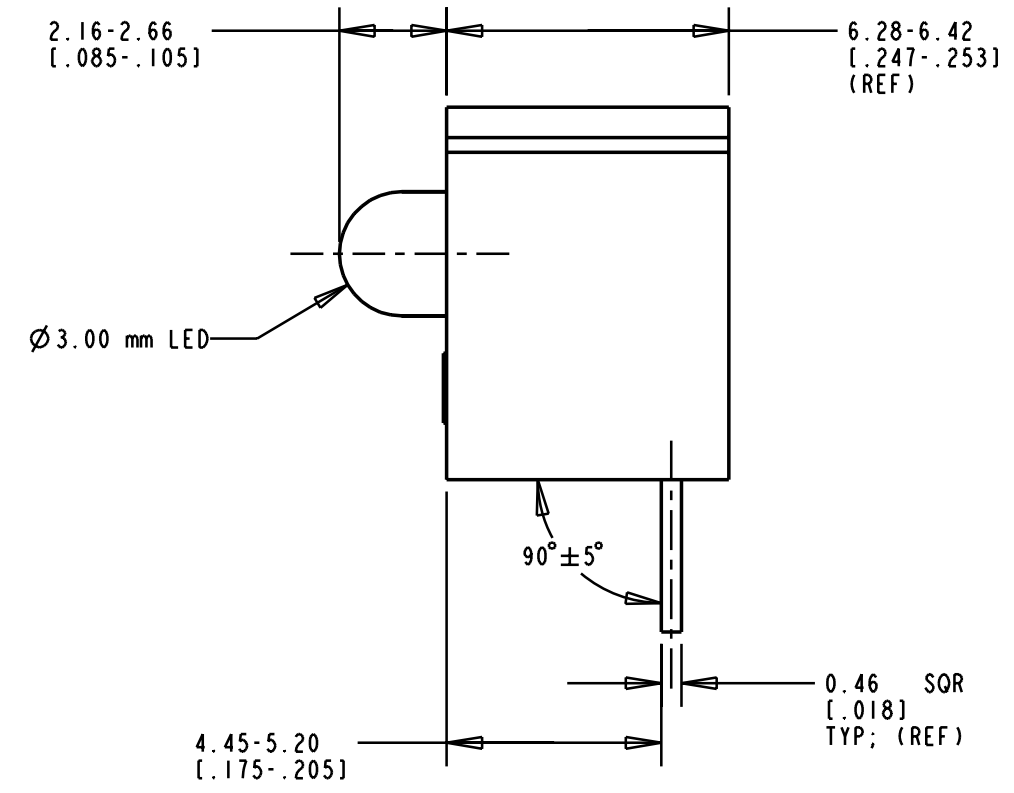
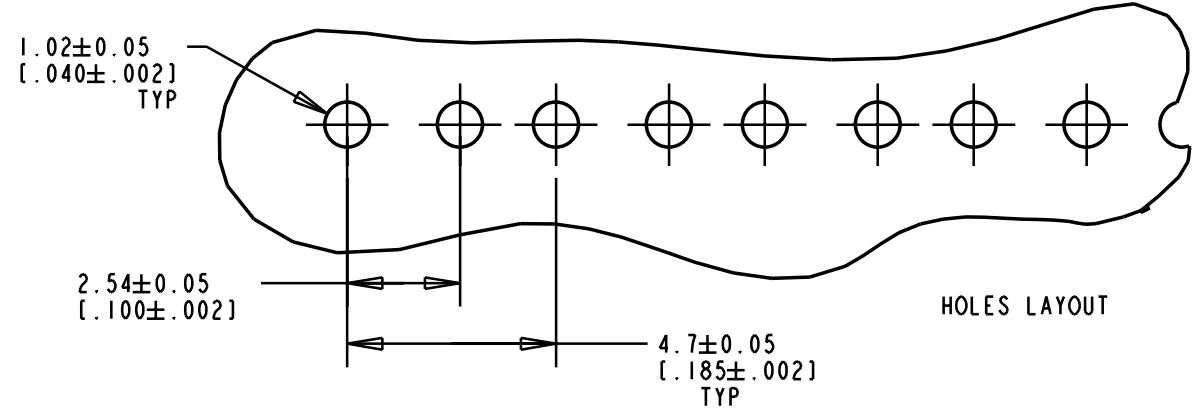
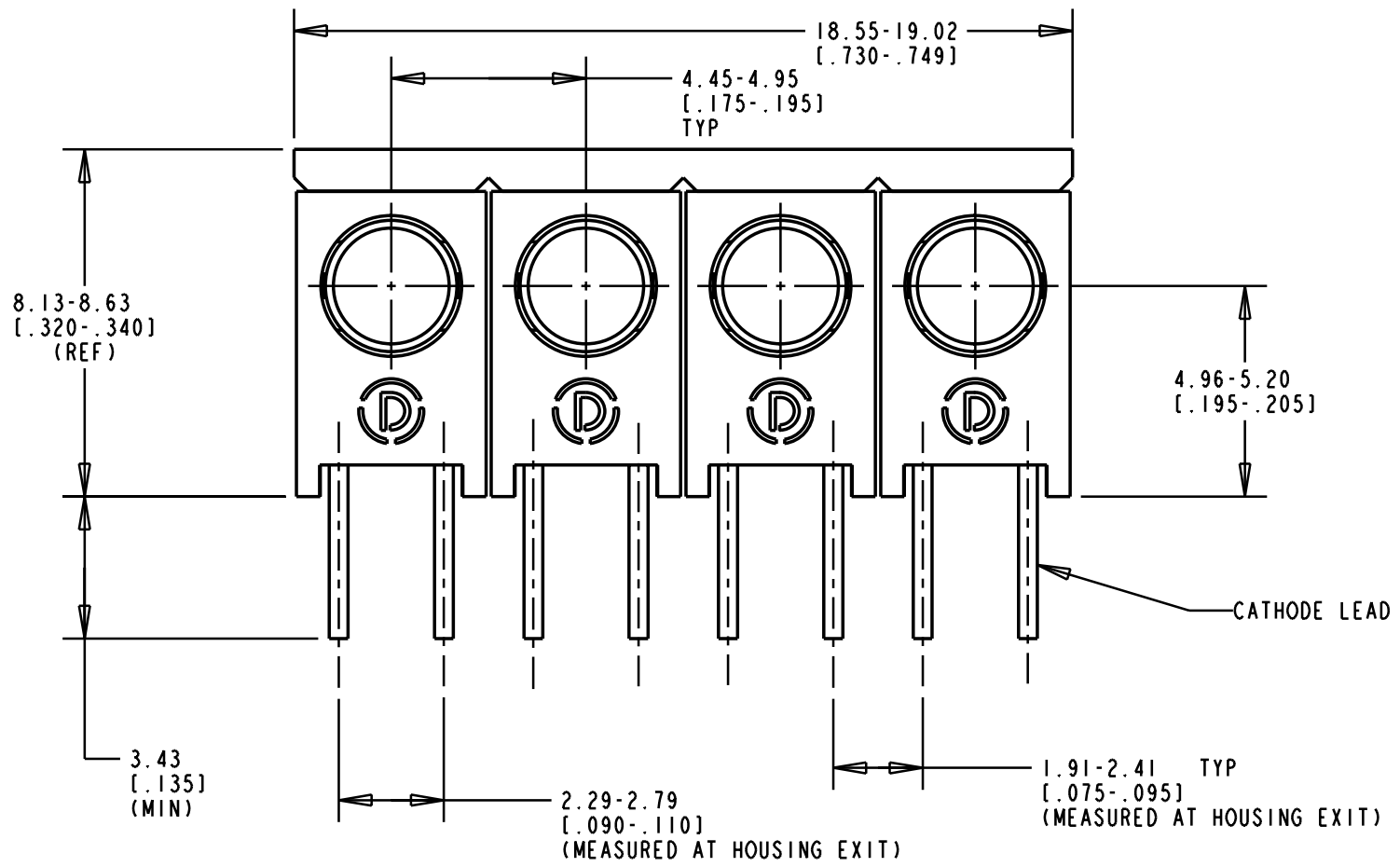

SCALE 3.000

THIS DRAWING AND THE CONTENTS HEREIN ARE CONFIDENTIAL AND THE SOLE PROPERTY OF DIALIGHT. REPRODUCTION OF THIS DRAWING OR CONSTRUCTION OF ANY PARTS WITHIN THIS DRAWING ARE FORBIDDEN WITHOUT THE WRITTEN CONSENT OF DIALIGHT.		
SCALE X:X	DRAWING NUMBER	REV
ALL DIM'S IN: INCHES	C-16483	A
TOLERANCES: UNLESS OTHERWISE SPECIFIED	TITLE	
FRACTIONS: ±1/64	Ø 3.00 mm CBI ARRAY, RED	
DECIMALS (.XX): ±.01	MATERIAL	
DECIMALS (.XXX): ±.005	Dialight	
DECIMALS (.XXXX): ±.0005	1913 ATLANTIC AVE.	
ANGLES: ±1°	MANASQUAN, N.J. 08736	
FINISH:	FSCM 83330	SHEET OF FAMILY TABLE: