



Chipsmall Limited consists of a professional team with an average of over 10 year of expertise in the distribution of electronic components. Based in Hongkong, we have already established firm and mutual-benefit business relationships with customers from,Europe,America and south Asia,supplying obsolete and hard-to-find components to meet their specific needs.

With the principle of “Quality Parts,Customers Priority,Honest Operation,and Considerate Service”,our business mainly focus on the distribution of electronic components. Line cards we deal with include Microchip,ALPS,ROHM,Xilinx,Pulse,ON,Everlight and Freescale. Main products comprise IC,Modules,Potentiometer,IC Socket,Relay,Connector.Our parts cover such applications as commercial,industrial, and automotives areas.

We are looking forward to setting up business relationship with you and hope to provide you with the best service and solution. Let us make a better world for our industry!



Contact us

Tel: +86-755-8981 8866 Fax: +86-755-8427 6832

Email & Skype: info@chipsmall.com Web: www.chipsmall.com

Address: A1208, Overseas Decoration Building, #122 Zhenhua RD., Futian, Shenzhen, China



Coaxial Line Stretchers

HLS Series

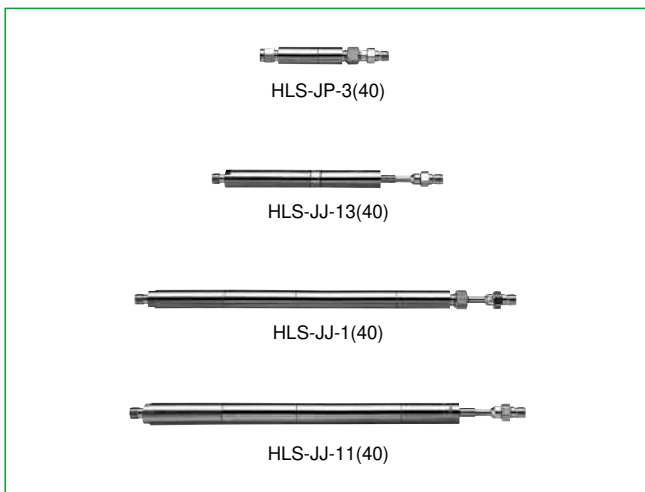

These coaxial line stretchers maintain an impedance of 50Ω while changing the length of the coaxial tube and adjusting the phase. One type is locked after the adjustment and another type can be used in mechanical drive applications.

These line stretchers are well suited for use in phase adjustment, impedance matching, and signal combining.

■ Features

1. Three Types of Adjustable Lengths

Adjustable lengths are available in these three types: 10 mm, 37.5 mm, and 75 mm.

2. High Reliability

Stainless steel is used for the connector portion and the gold plating high reliability.

■ Product Specifications

Ratings	Frequency range (Note) Characteristic impedance Maximum Input Power	DC to 10.0 GHz 50 ohms 50 W	Operating temperature range Operating relative humidity	-10°C to +65°C 95% Max.
---------	---	-----------------------------------	--	----------------------------

NOTE: The frequency range will depend on the model.

Item	Standard	Conditions
1. Vibration	No electrical discontinuity of 1 μs or more No damage, cracks, or parts dislocation	Frequency of 10 to 55 Hz, overall amplitude of 1.5 mm for 2 hours in each of 3 directions
2. Shock		Acceleration of 98 m/s ² , sine half-wave waveform, 3 cycles in each of the 3 axis
3. Temperature cycle	No damage, cracks, or parts dislocation	Temperature: -30°C→+15°C to +35°C→+70°C→+15°C to +35°C Time: 30→15 max.→30→15 max. (Minutes) 5 cycles

● The test method conforms to MIL-STD-202.

■ Materials

Part	Material	Finish
Body	Stainless steel	Gold plating
Connector Body	Brass	Gold plating
Coupling	Stainless steel	Gold plating
Female contact	Beryllium copper	Gold plating
Male contact	Brass	Gold plating
Insulator	PTFE	—
Coaxial tube	UT-141A semi-rigid cable	Gold plating
Lock nut	Brass	Gold plating

■ Ordering Information

HLS - JJ - 1 (40)

① ② ③ ④

① Series Name: HLS
② Connector Coupling Portion JP: Jack/Plug JJ: Jack/Jack
③ Suffix
④ (40): RoHS Compliant

■ Specifications

Part Number	Frequency Range (GHz)	V.S.W.R. (Max)	Length of Travel (mm)	Power (W)	Weight (g)	RoHS
HLS-JP-3(40)	DC~4 4~8	1.20 1.25	※10	50	29	YES
HLS-JJ-1(40)	DC~4 4~8	1.20 1.25	※75	50	91	
HLS-JJ-11(40)	DC~4 4~10	1.20 1.35	※75	50	91	
HLS-JJ-13(40)	DC~4 4~10	1.20 1.35	※37.5	50	46	

※With an air transmission path

External Dimensions

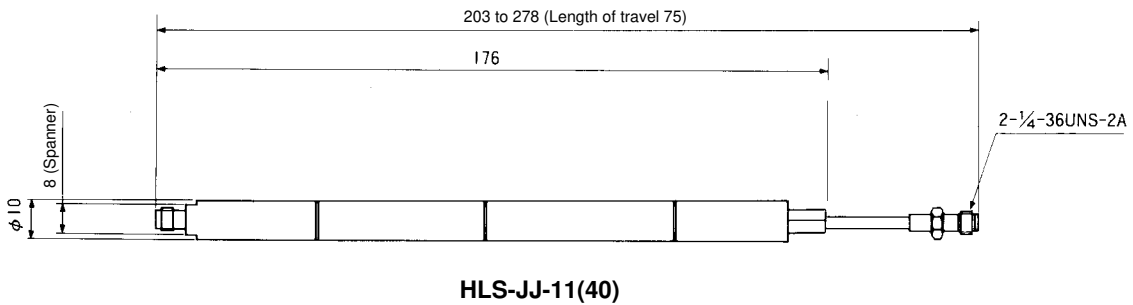
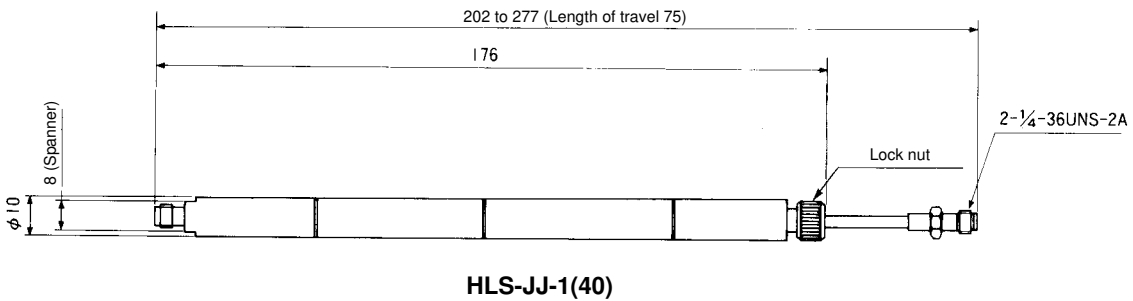
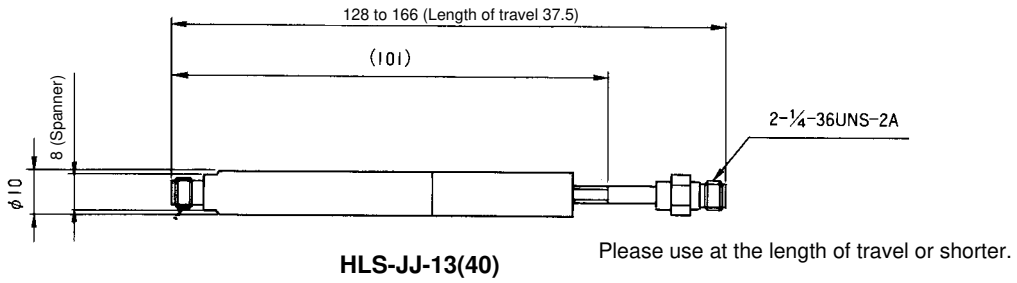
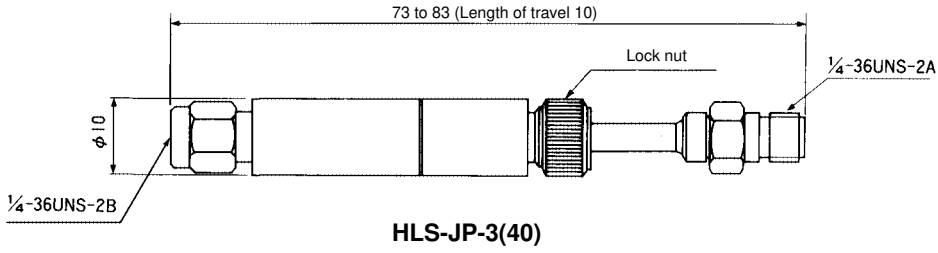

Typical Data

HLS-JJ-11

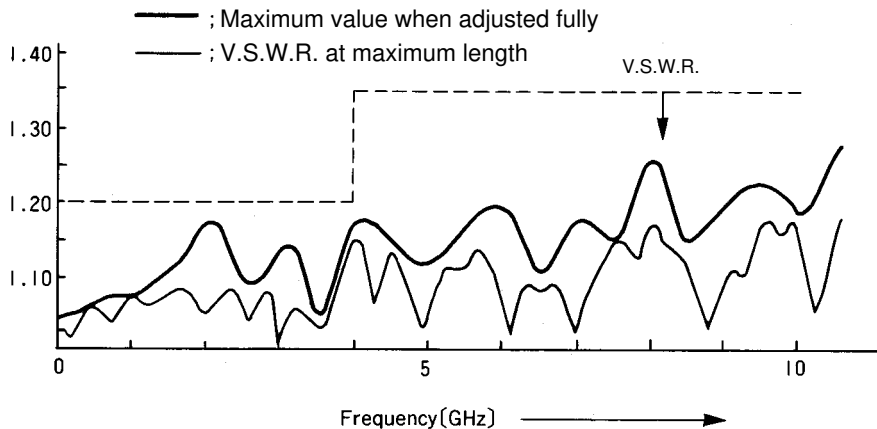

Coaxial Variable Phase Shifters

HLS Series

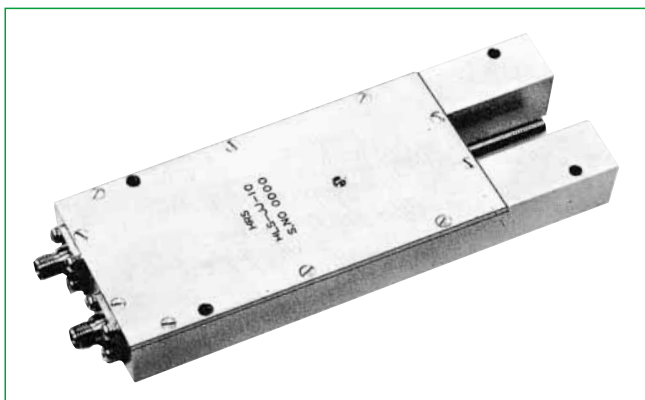

Features

1. Adjustment Screw Variation Method

These coaxial phase shifters use a method in which the adjustment screw is varied to adjust the phase. Phase adjustments are thereby permitted without adjusting the overall length. The adjustment screw is of the lock type and once locked there will be no shift of phase.

2.48 mm Adjustable Length

The length of travel is 48 mm.

Product Specifications

Ratings	Frequency range Characteristic impedance Maximum Input Power	DC to 4.0 GHz 50 ohms 50 W	Operating temperature range Operating relative humidity	-10°C to +65°C 95% Max.
---------	--	----------------------------------	--	----------------------------

Item	Standard	Conditions
1. Insulation	1,000 M ohms min.	500 V DC
2. Vibration	No electrical discontinuity of 1 μs or more	Frequency of 10 to 55 Hz, overall amplitude of 1.5 mm for 2 hours in each of 3 directions
3. Shock	No damage, cracks, or parts dislocation	Acceleration of 98 m/s ² , sine half-wave waveform, 3 cycles in each of the 3 axis
4. Temperature resistance cycle	No damage, cracks, or parts dislocation	Temperature: -30°C→+15°C to +35°C→+70°C→+15°C to +35°C Time: 30→15 max.→30→15 max. (Minutes) 5 cycles

● The test method conforms to MIL-STD-202.

Materials

Part	Materials	Finish
Connector Body	Stainless steel	Passivated
Body	Aluminum	—
Female contact	Beryllium copper	Gold plating
Male contact	Beryllium copper	Gold plating
Insulator	PTFE	—
Adjustment screw	Brass	Nickel plating

Ordering Information

HLS - JJ - 10 (40)

① ② ③ ④

① Series Name: HLS	
② Connector Coupling Portion	JJ: Jack/Jack
③ Suffix	
④ (40): RoHS Compliant	

Specifications

Part Number	Frequency Range (GHz)	V.S.W.R.(Max)	Insertion Loss (dB Max)	Length of travel (mm)	Power (W)	Weight (g)	RoHS
HLS-JJ-10	DC~1	1.2	0.3	With an air transmission path 48	50	192	YES
	1~2	1.3	0.4				
	2~4	1.5	0.5				

External Dimensions

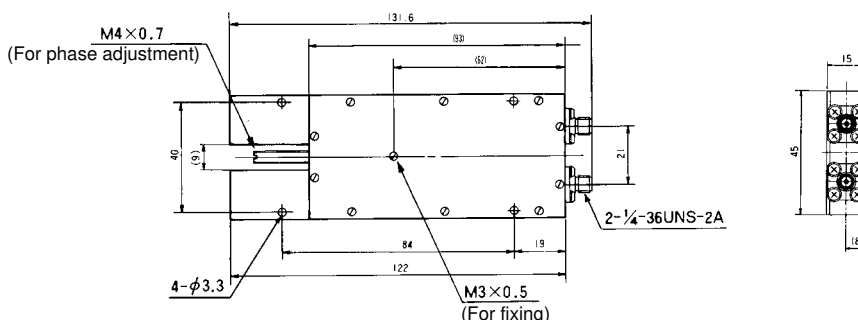

Coaxial Variable Phase Shifters

HLS Series

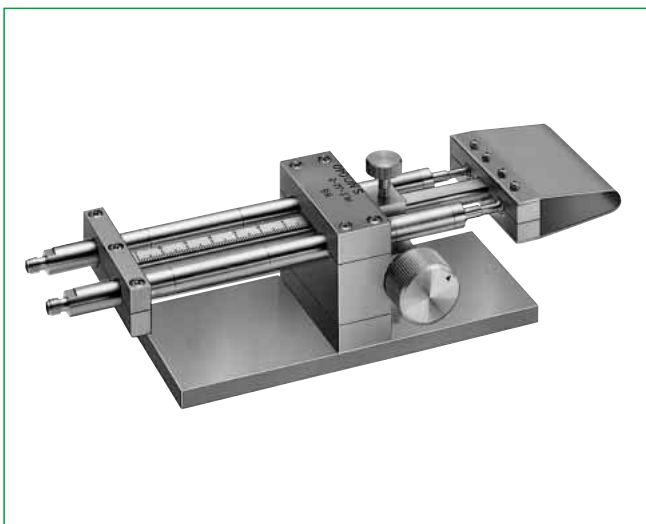

■Features

1.Adjustment Screw Variation Method

These coaxial phase shifters are adjusted by turning an adjustment screw which permits adjustment of the phase while maintaining an impedance of 50Ω.

The adjustment screw is of the lock type and once locked there will be no shift of phase.

2.140 mm Adjustable Length

The length of travel is 140 mm.

3.High Reliability

Stainless steel is used in the connector portion and the gold plating guarantees high reliability.

■Product Specifications

Ratings	Frequency range Characteristic impedance Maximum Input Power	DC to 4.0 GHz 50 ohms 50W	Operating temperature range Operating relative humidity	-10°C to +65°C 95% Max.
---------	--	---------------------------------	--	----------------------------

Item	Standard	Conditions
1.Insulation	1000 M ohms min.	50 V DC
2.Vibration	No electrical discontinuity of 1 μs or more No damage, cracks, or parts dislocation	Frequency of 10 to 55 Hz, overall amplitude of 1.5 mm for 2 hours in each of 3 directions
3.Shock		Acceleration of 98 m/s ² , sine half-wave waveform, 3 cycles in each of the 3 axis
4.Temperature resistance cycle	No damage, cracks, or parts dislocation	Temperature: -30°C→+15°C to +35°C→+70°C→+15°C to +35°C Time: 30→15 max.→30→15 max. (Minutes) 5 cycles

●The test method conforms to MIL-STD-202.

■Materials

Part	Material	Finish
Connector Body	Stainless steel	Gold plating
Body	Brass	Nickel plating
Female contact	Beryllium copper	Gold plating
Insulator	PTFE	—

■Ordering Information

HLS - JJ - 2 (40)
 ① ② ③ ④

① Series Name: HLS
② Connector Coupling Portion JJ: Jack/Jack
③ Suffix
④ (40): RoHS Compliant

■Specifications

Part Number	Frequency Range (GHz)	V.S.W.R. (Max)	Length of Travel (mm)	Power (W)	Weight (g)	RoHS
HLS-JJ-2	DC~4	1.3	With an air transmission path 140	50	2	YES

External Dimensions

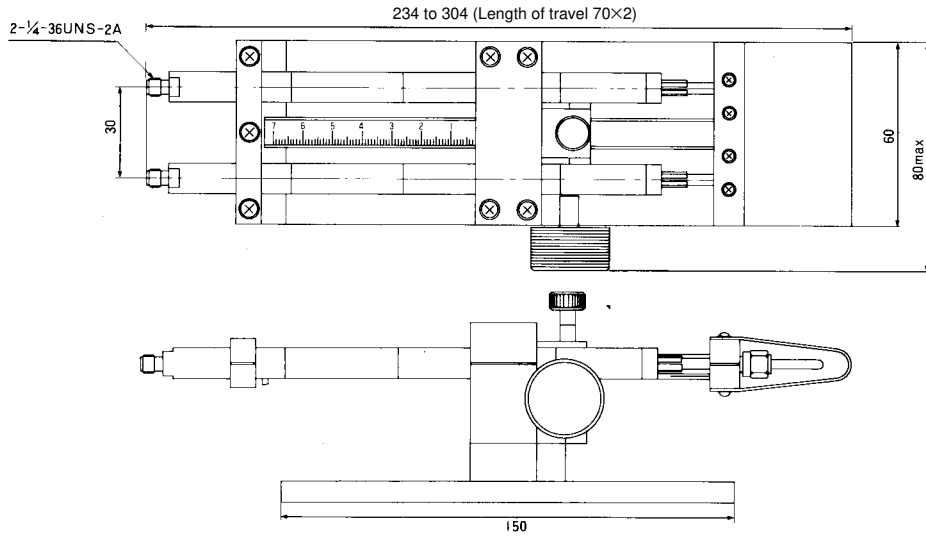

Relationship Between Shift Length, Delay Time, and Phase Angle

Shift Length L (mm), Delay Time T (ns), Frequency F (GHz), Phase Shift θ (deg)

$$T = \frac{L}{300}$$

$$\theta = 1.2 \times L \times F$$

