



Chipsmall Limited consists of a professional team with an average of over 10 year of expertise in the distribution of electronic components. Based in Hongkong, we have already established firm and mutual-benefit business relationships with customers from,Europe,America and south Asia,supplying obsolete and hard-to-find components to meet their specific needs.

With the principle of "Quality Parts,Customers Priority,Honest Operation,and Considerate Service",our business mainly focus on the distribution of electronic components. Line cards we deal with include Microchip,ALPS,ROHM,Xilinx,Pulse,ON,Everlight and Freescale. Main products comprise IC,Modules,Potentiometer,IC Socket,Relay,Connector.Our parts cover such applications as commercial,industrial, and automotives areas.

We are looking forward to setting up business relationship with you and hope to provide you with the best service and solution. Let us make a better world for our industry!



## Contact us

Tel: +86-755-8981 8866 Fax: +86-755-8427 6832

Email & Skype: info@chipsmall.com Web: www.chipsmall.com

Address: A1208, Overseas Decoration Building, #122 Zhenhua RD., Futian, Shenzhen, China



GEN. ST.	01	02	03	04	05	06	07	08	0D	50	60	70	80	90															
INT. ST.	10	11	12	13	14	18	20	31	32	33	34	38	39	40	42	43	44	45	46	48	56	70	72	73	76	81	83	84	88

REV.	DATE	DESCRIPTION	BY	C'K'D'
A	2001-09-14	CONVERSION REVISION 03	KN	
B	2005-10-26	105-0205	ALEX B	BKP
C	2006-08-08	106-0144	ALEX B	BKP

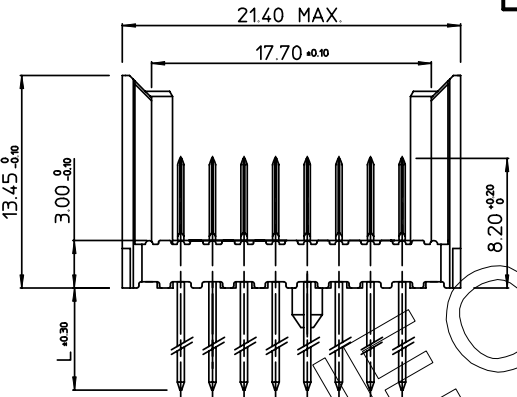
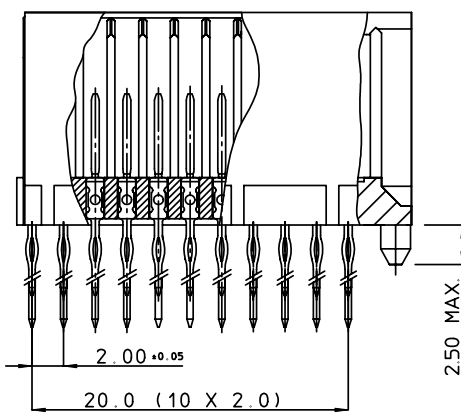

**PERFORMANCE CHARACTERISTICS**

CURRENT RATING : 1.5 A AT 20°C ( FULLY LOADED )  
 1 A AT 70°C ( FULLY LOADED )

RATED VOLTAGE : 500 V AC (CONT / CONT )

OPERATING TEMPERATURE : -55°C TO 125°C

CONTACT RESISTANCE : 20 mΩ MAX

INSERTION FORCE : 0.60 N MAX / CONT

EXTRACTION FORCE : 0.15 N MIN / CONT

INSULATION RESISTANCE : 10<sup>4</sup> MΩ MIN

CAT. NR.	L ±0.3	DESCRIPTION
HM2P89PD8110----	3.7	SHORT PRESS-FIT
HM2P89PC8110----	4.5	SHORT PRESS-FIT
HM2P89PK8110----	13	REAR PLUG-UP: LEVEL 1
HM2P89PM8110----	14.5	REAR PLUG-UP: LEVEL 2
HM2P89PN8110----	16	REAR PLUG-UP: LEVEL 3
HM2P89PT8110----	13	WIRE WRAP

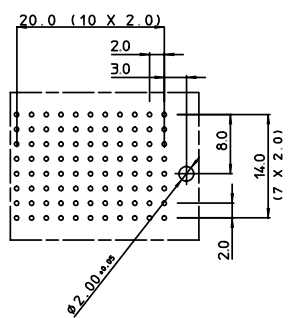
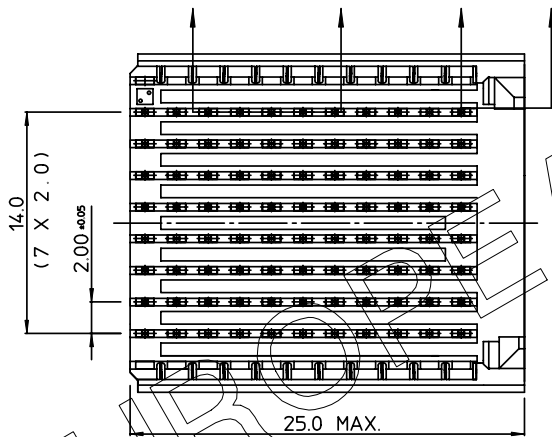

LAY-OUT  
P.C.B. - HOLE

**NOTES**

1. \*HM2P89P#8110<sup>C</sup>\*  
 PERFORMANCE LEVEL INDICATOR  
 (REFER DWG No. BS.C , 201844, 003)  
 LEAD FREE INDICATOR : LF-LEAD FREE  
 (DIGIT 15&16)
2. THIS PRODUCT IS CSA APPROVED.  
 THIS PRODUCT IS UL RECOGNIZED.
3. FOR RECOMMENDED PTH DIMENSIONS REFER DRAWING : BS.A , 201572, 001
4. THE PRODUCT (LF) MEETS EUROPEAN UNION DIRECTIVES AND OTHER COUNTRY REGULATIONS AS DESCRIBED IN GS-22-008

**MALE SIGNAL STRAIGHT PRESS-FIT-TO-BOARD CONNECTOR  
EXTENSION MODULE (WIDE BODY)**

1DEC ±0.2 2DEC ±0.1 ANGLES ±1°	<b>APPR.</b>	<b>DATE</b>	<b>SIGN.</b>	MILLIPACS 2 / TYPE F (8 ROW) / NO SHIELDING
	DRAFT	1996-04-30	W. Panie	<b>CAT. No.</b> HM2P89P#8110----
	CHECKED			
WE RESERVE THE RIGHT TO CHANGE DIMENSIONS OR REQUIREMENTS WITHOUT PRIOR NOTICE.	PROD. MGR.			<b>SCALE</b>
	PR. ENG. MGR.			3/1
	PR. MGT. MGR.			

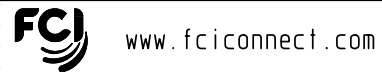

ALL DIMENSIONS IN MM

**REFERENCES**

BS.C , 202259, 003 C

**PDM: Rev:C** STATUS: **Released** DRAWING No. 3 CUSTOMER DRAWING REVISION 2

Printed: Dec 02, 2007

THIS IS OUR EXCLUSIVE PROPERTY. IT IS NOT TO BE COPIED, REPRINTED OR DISCLOSED TO A THIRD PARTY. NOR USED FOR MANUFACTURING WITHOUT OUR WRITTEN CONSENT, AND HAS TO BE RETURNED TO US IN CASE OF NO USAGE

DIT IS ONZE EIGENDOM EN MAG NOCH NAGEMAAKT. HERDRUKT, OVERGEMAAKT AAN DERDEN, NOCH VOOR FABRIKATIE GEBRUIKT WORDEN, ZONDER ONZE SCHRIFTELIJKE TOELATING. BIJ NIET GEBRUIK IS TERUGZENDING VERPLICHT.