



Chipsmall Limited consists of a professional team with an average of over 10 year of expertise in the distribution of electronic components. Based in Hongkong, we have already established firm and mutual-benefit business relationships with customers from,Europe,America and south Asia,supplying obsolete and hard-to-find components to meet their specific needs.

With the principle of “Quality Parts,Customers Priority,Honest Operation,and Considerate Service”,our business mainly focus on the distribution of electronic components. Line cards we deal with include Microchip,ALPS,ROHM,Xilinx,Pulse,ON,Everlight and Freescale. Main products comprise IC,Modules,Potentiometer,IC Socket,Relay,Connector.Our parts cover such applications as commercial,industrial, and automotives areas.

We are looking forward to setting up business relationship with you and hope to provide you with the best service and solution. Let us make a better world for our industry!



Contact us

Tel: +86-755-8981 8866 Fax: +86-755-8427 6832

Email & Skype: info@chipsmall.com Web: www.chipsmall.com

Address: A1208, Overseas Decoration Building, #122 Zhenhua RD., Futian, Shenzhen, China



Tous droits strictement reserves. Reproduction ou communication a des tiers interdite sous quelque forme que ce soit sans autorisation ecrite du propriétaire. Propriete de c FCI. Droits de reproduction FCI.



All rights strictly reserved. Reproduction or issue to third parties in any form whatever is not permitted without written authority from the proprietor. Property of FCI. Copyright FCI.

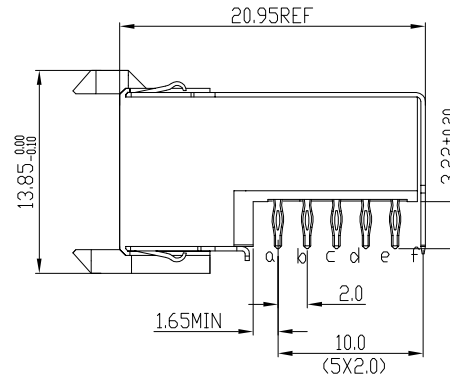
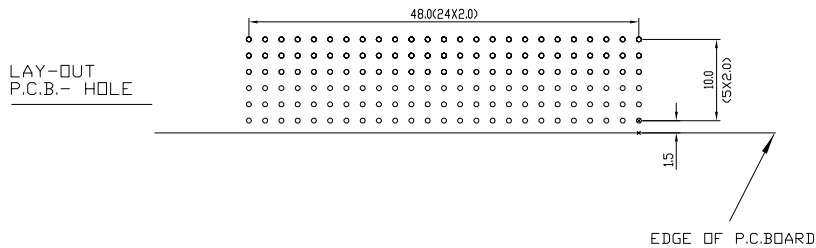
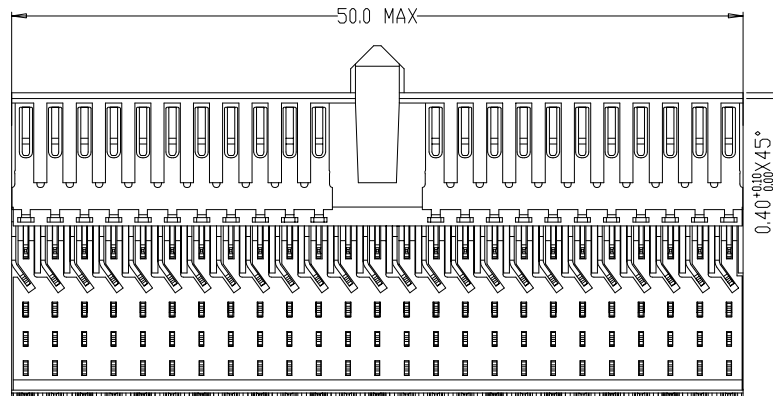
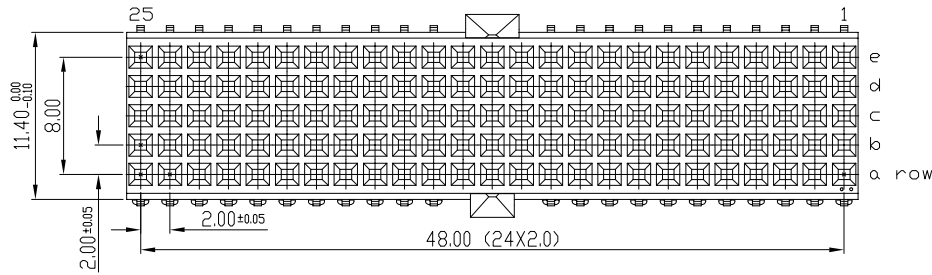

PERFORMANCE CHARACTERISTICS

CURRENT RATING: 1.5 A AT 20°C (FULLY LOADED)
 1 A AT 70°C (FULLY LOADED)
 RATED VOLTAGE: 500 V AC (CONT /CONT)
 OPERATING TEMPERATURE : -55°C TO 125°C
 CONTACT RESISTANCE : 20 mΩ MAX
 INSERTION FORCE: 0.75N MAX/CONT
 EXTRACTION FORCE : 0.15N MIN /CONT
 INSULATION RESISTANCE: 10⁴ MΩ MIN

NOTES

- LEAD FREE INDICATOR :LF=LEAD FREE
- PERFORMANCE LEVEL INDICATOR (REF DWG NO.BS.C.201844.003)
- THIS PRODUCT IS CSA APPROVED. THIS PRODUCT IS UL RECOGNIZED.
- FOR RECOMMENDED PTH DIMENSIONS REFER DRAWING :BSA.201572.001
- THIS PRODUCT (LF) MEETS EUROPEAN UNION DIRECTIVES AND OTHER COUNTRY REGULATIONS AS DESCRIBED IN GS-22-008

rev	ecn no	dr	date
A	conversion version 03	KN	14-09-01
B	DG05-0278	Koson	02-08-05
C	DG07-0362	Koson	05-09-07
D	DG10-0110	NZ	05-30-10

Material		Spec ref		
Mat code		✓	tolerance	projection
Heat treat			1DEC+02 1DEC 2DEC ± 0.1 2DEC ANGLES+1+0EKEN	
Plating/Finish		size		MM
Dr	N.OTTO	06-05-99	A4	Scale 1.500
Eng			Product family MILLIPICS	
Chr			Model Name	
Appr			Model Revision	
			REL Level	
		title	Rev. D	
Pro/E file		catalog no	dwg no	
		HM2R65PA5101----	BS,C ,201444,039	
			CUSTOMER	sheet 1 of 1