



Chipsmall Limited consists of a professional team with an average of over 10 year of expertise in the distribution of electronic components. Based in Hongkong, we have already established firm and mutual-benefit business relationships with customers from,Europe,America and south Asia,supplying obsolete and hard-to-find components to meet their specific needs.

With the principle of “Quality Parts,Customers Priority,Honest Operation,and Considerate Service”,our business mainly focus on the distribution of electronic components. Line cards we deal with include Microchip,ALPS,ROHM,Xilinx,Pulse,ON,Everlight and Freescale. Main products comprise IC,Modules,Potentiometer,IC Socket,Relay,Connector.Our parts cover such applications as commercial,industrial, and automotives areas.

We are looking forward to setting up business relationship with you and hope to provide you with the best service and solution. Let us make a better world for our industry!



Contact us

Tel: +86-755-8981 8866 Fax: +86-755-8427 6832

Email & Skype: info@chipsmall.com Web: www.chipsmall.com

Address: A1208, Overseas Decoration Building, #122 Zhenhua RD., Futian, Shenzhen, China



Three-Axis Magnetic Sensor HMC1043L

The Honeywell HMC1043L is a miniature three-axis surface mount sensor array designed for low field magnetic sensing. By adding the HMC1043L with supporting signal processing, a cost effective and space-efficient three-axis magnetometer or compassing solution is enabled. This ultra-compact, low cost solution is easy to assemble for high volume OEM designs. Applications for the HMC1043L include Compassing, Navigation Systems, Magnetometry, and Current Sensing.

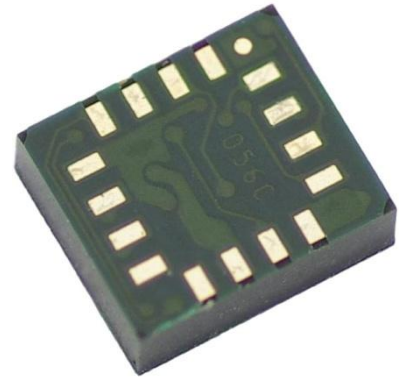

The HMC1043L utilizes Honeywell's Anisotropic Magnetoresistive (AMR) technology that provides advantages over coil based magnetic sensors. They are extremely sensitive, low field, solid-state magnetic sensors designed to measure direction and magnitude of Earth's magnetic fields. Honeywell's Magnetic Sensors are among the most sensitive and reliable low-field sensors in the industry.

Honeywell continues to maintain product excellence and performance by introducing innovative solid-state magnetic sensor solutions. These are highly reliable, top performance products that are delivered when promised. Honeywell's magnetic sensor solutions provide real solutions you can count on.

FEATURES

- ▶ Low Noise and Highly Linear
- ▶ Low Height Magnetic Sensors (1.2mm)
- ▶ Surface Mount Three-Axis Sensors
- ▶ Low Voltage Operations (2.0V)
- ▶ Available in Tape & Reel Packaging
- ▶ 4-Element Wheatstone Bridges
- ▶ Wide Magnetic Field Range (+/-6 Oe)
- ▶ Patented Offset and Set/Reset Straps
- ▶ Lead Free Package Construction

BENEFITS

- ▶ Supports the Creation of High Accuracy Compasses and Ferrous Anomaly Detection including Vehicle Detection Systems
- ▶ Narrow Dimensions and Small Size for Low Profile Vertical Sensing Applications and Mounting, No Layout Constraints
- ▶ Easy to Assemble & Compatible with High Speed SMT Assembly
- ▶ Compatible for Battery Powered Applications
- ▶ High Volume OEM Assembly
- ▶ Low Noise Passive Element Design
- ▶ Sensor Can Be Used in Strong Magnetic Field Environments
- ▶ Stray Magnetic Field Compensation
- ▶ RoHS Compliance

SPECIFICATIONS – PRELIMINARY DOCUMENT. SUBJECT TO CHANGE.

Characteristics	Conditions	Min	Typ	Max	Units
Bridge Elements					
Supply ⁽¹⁾	VB referenced to VSS	1.8	3.0	10	Volts
Resistance ⁽²⁾	Bridge current = 10mA Resistance per bridge Resistance measured VB to VSS	800 265	1000 333	1500 500	ohms ohms
Operating Temperature ⁽³⁾		-40		125	°C
Storage Temperature ⁽³⁾	Unbiased	-55		150	°C
Field Range ⁽³⁾	Full scale (FS) – total applied field	-6		+6	gauss
Linearity Error ⁽³⁾	Best fit straight line ± 1 gauss ± 3 gauss ± 6 gauss		0.1 0.4 1.4		%FS
Hysteresis Error ⁽³⁾	3 sweeps across ±3 gauss		0.06		%FS
Repeatability Error ⁽³⁾	3 sweeps across ±3 gauss		0.1		%FS
Bridge Offset ⁽²⁾	Offset = (OUT+) – (OUT-) Field = 0 gauss, After Set pulse	-1.25	±0.5	+1.25	mV/V
Sensitivity ⁽²⁾	Set/Reset Current = 0.5A per strap	0.8	1.0	1.2	mV/V/gauss
Noise Density ⁽³⁾	@ 1 Hz, VB=5V		50		nV/sqrt Hz
Resolution ⁽³⁾	50Hz Bandwidth, VB=5V		120		μgauss
Bandwidth ⁽³⁾	Magnetic signal (lower limit = DC)		5		MHz
Disturbing Field ⁽³⁾	Sensitivity starts to degrade. Use S/R pulse to restore sensitivity.	20			gauss
Sensitivity Tempco ⁽³⁾	T _A = -40 to 125°C, VB=5V	-3700	-3400	-3100	ppm/°C
Bridge Offset Tempco ⁽³⁾	T _A = -40 to 125°C, No Set/Reset, ±1 gauss T _A = -40 to 125°C, With Set/Reset		±700 ±10		ppm/°C
Bridge Ohmic Tempco ⁽³⁾	VB=5V, T _A = -40 to 125°C	2100	2400	2700	ppm/°C
Cross-Axis Effect ⁽³⁾	Cross field = 1 gauss, Happlied = ±1 gauss		±0.3		%FS
X,Y,Z Sensor Alignment ⁽¹⁾	Sensor alignment to package edge		±2.0		degrees
X to Y orthogonality ⁽³⁾	Angle between X and Y sensitive axes		87.5		degrees

Set/Reset Straps

Resistance ⁽²⁾	Measured from S/R+ to S/R-	1.5	2.5	3.3	ohms
Current ⁽³⁾	0.1% duty cycle, or less, 2μsec current pulse	1.2	1.5	2	Amp
Resistance Tempco ⁽³⁾	T _A = -40 to 125°C	3300	3700	4100	ppm/°C

Offset Straps

Resistance ⁽²⁾	Measured from OFF+ to OFF-	10	13	19	ohms
Offset Constant ⁽³⁾	DC Current Field applied in sensitive direction		10		mA/gauss
Resistance Tempco ⁽³⁾	T _A = -40 to 125°C	3500	3900	4300	ppm/°C

(1) By Design

(2) Tested at 25°C except stated otherwise.

(3) Characterized

SCHEMATIC DIAGRAM

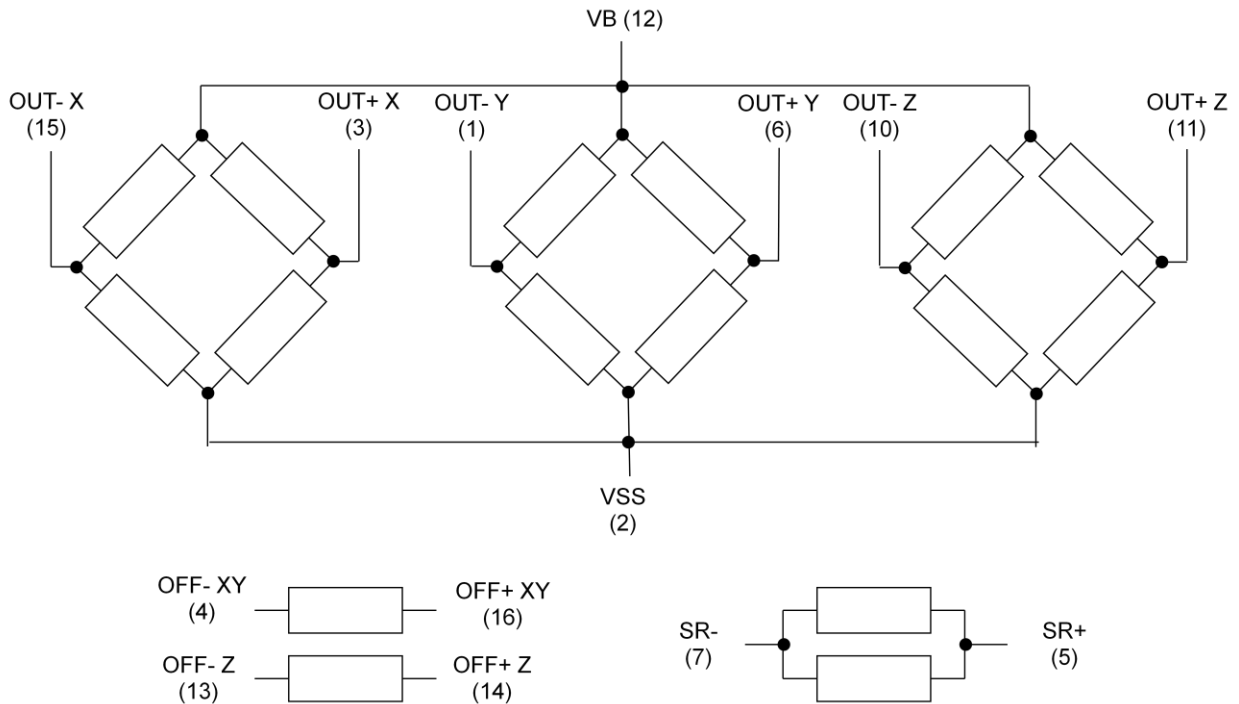

PIN CONFIGURATIONS

(Arrow indicates direction of applied field that generates a positive output voltage after a SET pulse.)

Pin Number	Function	Pin Number	Function
1	OUT- Y	9	NC
2	VSS	10	OUT- Z
3	OUT+ X	11	OUT+ Z
4	OFF- XY	12	VB
5	SR+	13	OFF- Z
6	OUT+ Y	14	OFF+ Z
7	SR-	15	OUT-X
8	NC	16	OFF+ XY

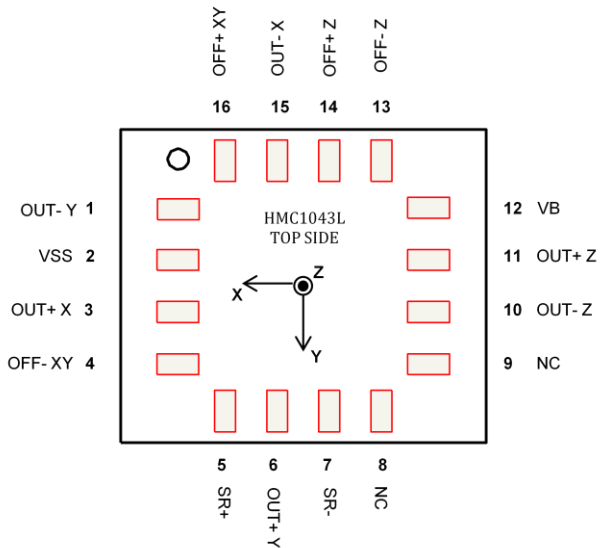

Externally applied magnetic fields
(Top View)

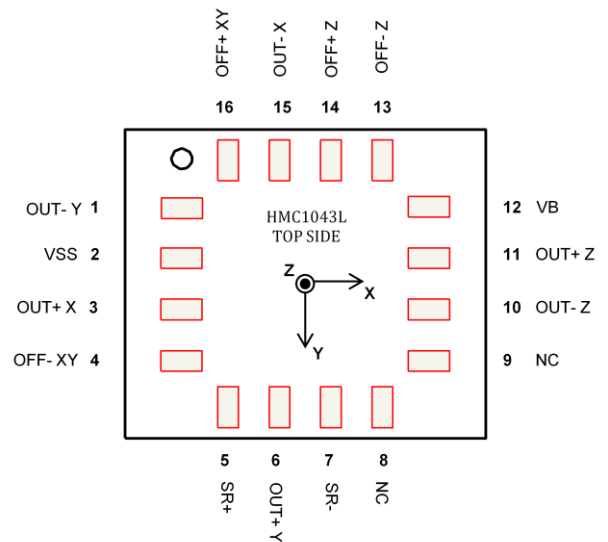

Internally applied magnetic fields - Offset Straps
(Top View)

PACKAGE OUTLINE HMC1043L

PACKAGE DRAWING HMC1043L (16-PIN LPCC)

*Weight = 25.6 milli-grams

DIMENSIONS									
Ref.	Databook (mm)			Drawing (mm)			Drawing (inches)		
	Min.	Typ.	Max.	Min.	Typ.	Max.	Min.	Typ.	Max.
E1	3.350	3.500	3.650	3.450	3.500	3.550	0.1358	0.1378	0.1398
D1	2.850	3.000	3.150	2.950	3.000	3.050	0.1161	0.1181	0.1201
A1	1.100	1.200	1.300	1.150	1.200	1.250	0.0453	0.0472	0.0492
L1	1.450	1.500	1.550	1.460	1.500	1.540	0.0575	0.0591	0.0606
N1	0.700	0.750	0.800	1.710	0.750	0.790	0.0673	0.0295	0.0311
N2	0.450	0.500	0.550	0.460	0.500	0.540	0.0181	0.0197	0.0213
P1	1.150	1.200	1.250	1.160	1.200	1.240	0.0457	0.0472	0.0488
P2	1.150	1.200	1.250	1.160	1.200	1.240	0.0457	0.0472	0.0488
T1	0.350	0.400	0.450	0.360	0.400	0.440	0.0142	0.0157	0.0173
T2	0.150	0.200	0.250	0.160	0.200	0.240	0.0063	0.0079	0.0094
d	0.150	0.200	0.250	0.160	0.200	0.240	0.0063	0.0079	0.0094
K		0.050			0.050			0.0020	
M1		0.100		0.060	0.100	0.140	0.0024	0.0039	0.0055
M2		0.350		0.310	0.350	0.390	0.0112	0.0137	0.0153

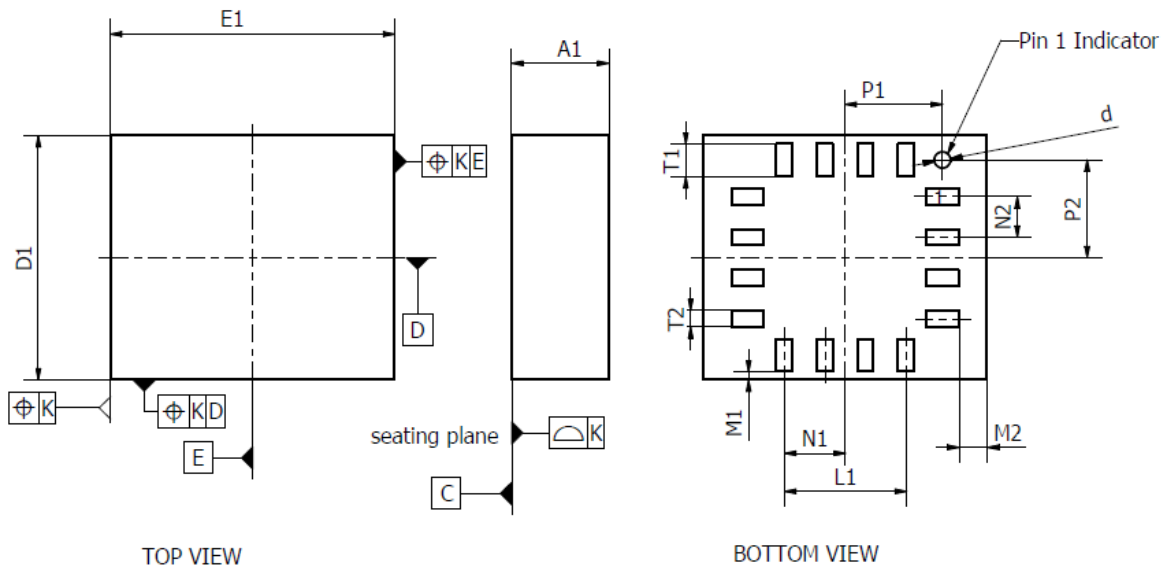

MOUNTING CONSIDERATIONS

The following is the recommend printed circuit board (PCB) footprint for the HMC1043L.

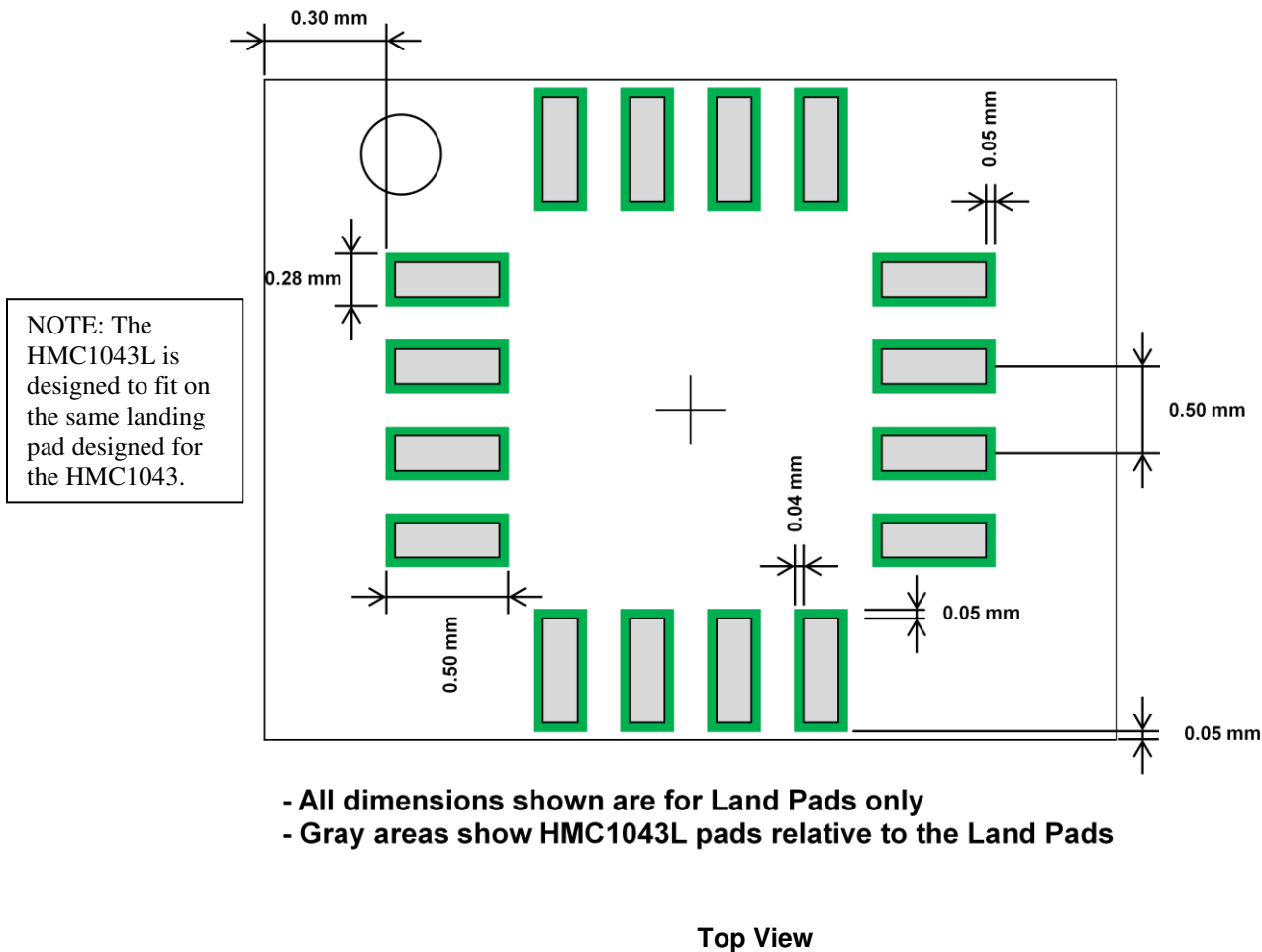

Pad Layout

Each of the sixteen pads on the HMC1043L is spaced on 0.5mm centers with 4 pads per side. Each pad is nominally 0.20mm by 0.40mm with a gold finish.

Reflow and Rework

This device has been tested to MSL 3 with 260 °C peak reflow temperature. A baking process (125 °C, 24 hrs) is required if device is not kept continuously in a dry (< 10% RH) environment before assembly. No special reflow profile is required for HMC1043L which is compatible with lead eutectic and lead-free solder paste reflow profiles. Honeywell recommends the adherence to solder paste manufacturer's guidelines.

BASIC DEVICE OPERATION

The Honeywell HMC1043L magnetoresistive sensors are Wheatstone bridges to measure magnetic fields. With power supply applied to the bridges, the sensors convert any incident magnetic field in the sensitive axis directions to a differential voltage outputs. In addition to the bridge circuits, each sensor has two on-chip magnetically coupled straps; the offset strap and the set/reset strap. These straps are Honeywell patented features for incident field adjustment and magnetic domain alignment; and eliminate the need for external coils positioned around the sensors.

The magnetoresistive sensors are made of a nickel-iron (Permalloy) thin-film deposited on a silicon wafer and patterned as a resistive strip element. In the presence of a magnetic field, a change in the bridge resistive elements causes a corresponding change in voltage across the bridge outputs.

These resistive elements are aligned together to have a common sensitive axis (indicated by arrows on the pinouts) that will provide positive voltage change with magnetic fields increasing in the sensitive direction. Because the output only is in proportion to the one-dimensional axis (the principle of anisotropy) and its magnitude, additional sensor bridges placed at orthogonal directions permit accurate measurement of arbitrary field direction. The combination of sensor bridges in two and three orthogonal axis permit applications such as compassing and magnetometry.

The offset straps allow for auto-calibration of bridge gain.

The set/reset strap can be pulsed with high currents for the following benefits: 1) Enable the sensor to perform high sensitivity measurements, 2) Flip the polarity of the bridge output voltage, and 3) Periodically used to improve linearity, lower cross-axis effects, and temperature effects.

Offset Straps

The offset strap is a spiral of metallization that couples in the sensor element's sensitive axis. The straps will easily handle currents to buck or boost fields through the ± 6 gauss linear measurement range, but designers should note the extreme thermal heating on the die when doing so.

With most applications, the offset strap is not utilized and can be ignored. Designers can leave one or both strap connections (Off- and Off+) open circuited, or ground one connection node. Do not tie both strap connections together to avoid shorted turn magnetic circuits.

Set/Reset Straps

The set/reset strap is another spiral of metallization that couples to the sensor elements easy axis (perpendicular to the sensitive axis on the sensor die. With rare exception, the set/reset strap must be used to periodically condition the magnetic domains of the magneto-resistive elements for best and reliable performance.

A set pulse is defined as a positive pulse current entering the S/R+ strap connection. The successful result would be the magnetic domains aligned in a forward easy-axis direction so that the sensor bridge's polarity is a positive slope with positive fields on the sensitive axis result in positive voltages across the bridge output connections.

A reset pulse is defined as a negative pulse current entering the S/R+ strap connection. The successful result would be the magnetic domains aligned in a reverse easy-axis direction so that sensor bridge's polarity is a negative slope with positive fields on the sensitive axis result in negative voltages across the bridge output connections.

Typically a reset pulse is sent first, followed by a set pulse a few milliseconds later. By shoving the magnetic domains in completely opposite directions, any prior magnetic disturbances will be completely erased by the duet of pulses. For simpler circuits with less critical requirements for noise and accuracy, a single polarity pulse circuit may be employed (all sets or all resets). With these uni-polar pulses, several pulses together become close in performance to a set/reset pulse circuit. Figure 1 shows an H-Bridge Set/Reset circuit that will generate both set and reset pulses to the set/reset strap. Additional information and examples on set/reset pulse circuits can be found in our application notes AN201 and AN213.

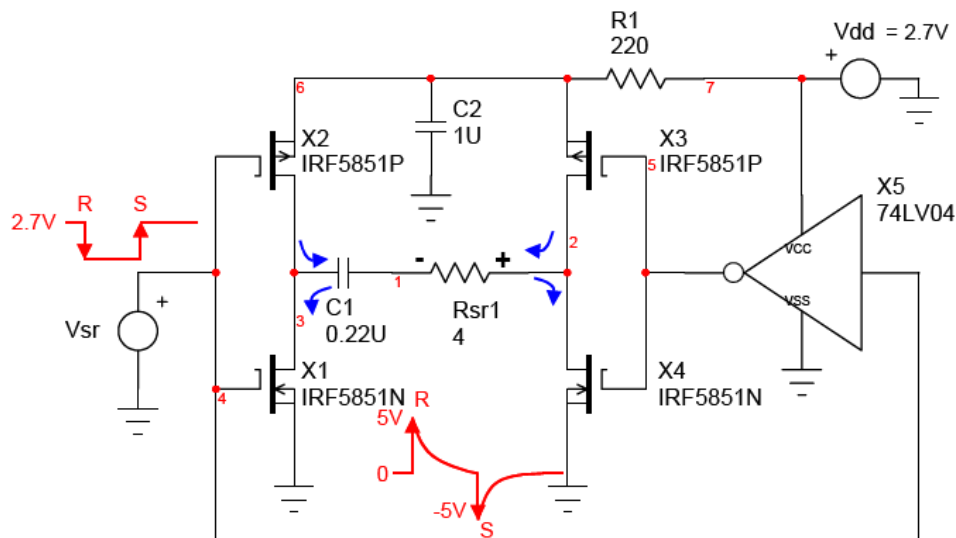
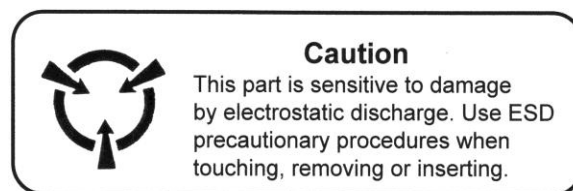

Figure 1: Example H-Bridge Set/Reset Pulse Circuit From AN213

ORDERING INFORMATION

Ordering Number	Product
HMC1043L HMC1043L-TR	Cut Tape Tape and Reel with 1k units/reel



CAUTION: ESDS CAT. 1B

FIND OUT MORE

For more information on Honeywell's Magnetic Sensors visit us online at www.magneticsensors.com or contact us at 1-800-323-8295.

The application circuits herein constitute typical usage and interface of Honeywell product. Honeywell does not warranty or assume liability of customer-designed circuits derived from this description or depiction.

Honeywell reserves the right to make changes to improve reliability, function or design. Honeywell does not assume any liability arising out of the application or use of any product or circuit described herein; neither does it convey any license under its patent rights nor the rights of others.

U.S. Patents 4,441,072, 4,533,872, 4,569,742, 4,681,812, 4,847,584 6,529,114 and 7,095,226 apply to the technology described