



Chipsmall Limited consists of a professional team with an average of over 10 year of expertise in the distribution of electronic components. Based in Hongkong, we have already established firm and mutual-benefit business relationships with customers from,Europe,America and south Asia,supplying obsolete and hard-to-find components to meet their specific needs.

With the principle of “Quality Parts,Customers Priority,Honest Operation,and Considerate Service”,our business mainly focus on the distribution of electronic components. Line cards we deal with include Microchip,ALPS,ROHM,Xilinx,Pulse,ON,Everlight and Freescale. Main products comprise IC,Modules,Potentiometer,IC Socket,Relay,Connector.Our parts cover such applications as commercial,industrial, and automotives areas.

We are looking forward to setting up business relationship with you and hope to provide you with the best service and solution. Let us make a better world for our industry!



Contact us

Tel: +86-755-8981 8866 Fax: +86-755-8427 6832

Email & Skype: info@chipsmall.com Web: www.chipsmall.com

Address: A1208, Overseas Decoration Building, #122 Zhenhua RD., Futian, Shenzhen, China



GaAs pHEMT SPDT NON-REFLECTIVE SWITCH, 0.1 - 20 GHz

Typical Applications

This switch is suitable for 0.1 - 20 GHz applications:

- Fiber Optics
- Microwave Radio
- Military
- Space
- VSAT

Features

- High Isolation: 45 dB @ 20 GHz
- Low Insertion Loss: 1.7 dB @ 20 GHz
- Non-Reflective Design
- Small Size: 1.3 x 0.85 x 0.1 mm

Functional Diagram

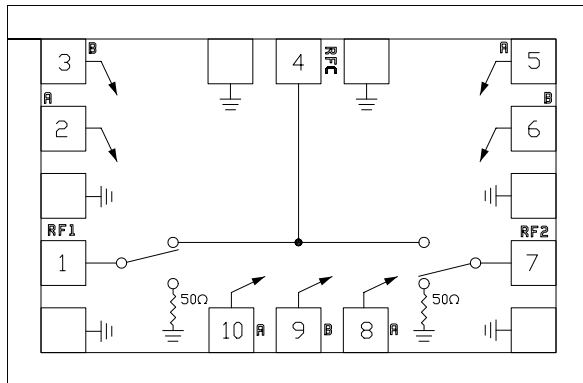

General Description

The HMC347B is a broadband non-reflective GaAs pHEMT SPDT MMIC chip. Covering 0.1 to 20 GHz, the switch offers high isolation and low insertion loss. The switch features over 52 dB isolation at lower frequencies and over 45 dB at higher frequencies due to the implementation of on-chip via hole structures. The switch operates using two negative control voltage logic lines of -5/0V, requires no Vee and has no current consumption. The switch operates down to 0.1 GHz. The chip features coplanar I/Os that allow 100% RF testing prior to delivery to the customer.

Electrical Specifications, $T_A = +25^\circ\text{C}$, With 0/-5V Control, 50 Ohm System

Parameter	Frequency	Min.	Typ.	Max.	Units
Insertion Loss	0.1 - 10.0 GHz		1.6		dB
	0.1 - 20.0 GHz		1.7	2.2	dB
Isolation	0.1 - 10.0 GHz		52		dB
	0.1 - 20.0 GHz	40	45		dB
Return Loss	"On State"		12		dB
Return Loss RF1, RF2	"Off State"		18		dB
Input Power for 1 dB Compression	0.5 - 20.0 GHz	23	25		dBm
Input Third Order Intercept Two-tone Input Power = +10dBm/tone	0.5 - 20.0 GHz		41		dBm
Switching Characteristics	0.1 - 20.0 GHz		3		ns
		tRISE, tFALL (10/90% RF) tON, tOFF (50% CTL to 10/90% RF)		10	

GaAs pHEMT SPDT NON-REFLECTIVE SWITCH, 0.1 - 20 GHz

Insertion Loss

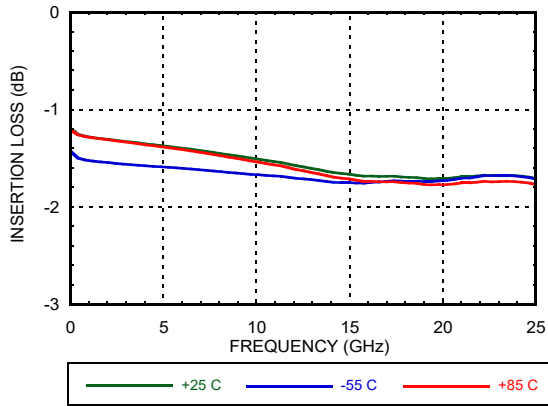

Isolation

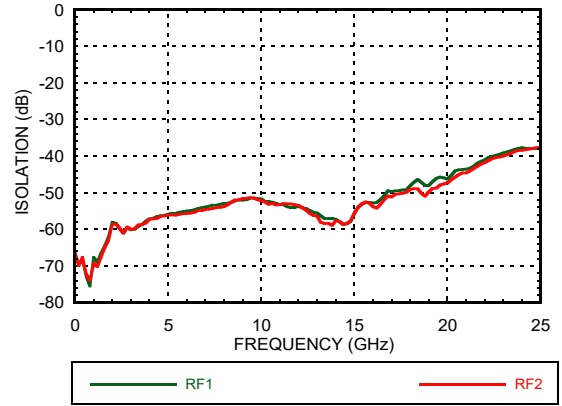

Return Loss

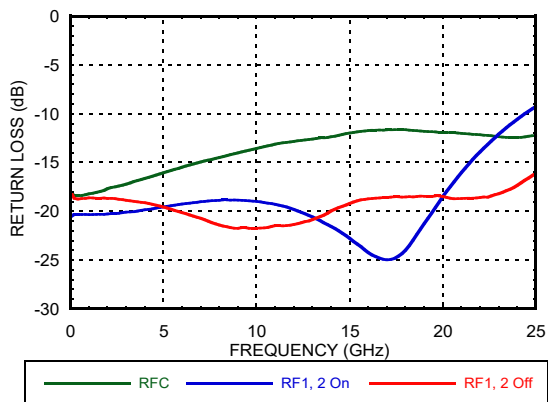

0.1 and 1 dB Input Compression Point

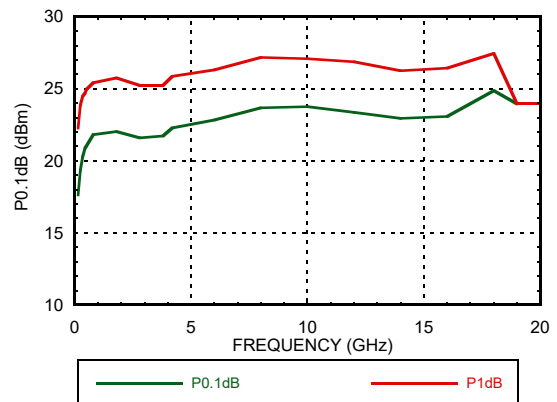

Input Third Order Intercept Point

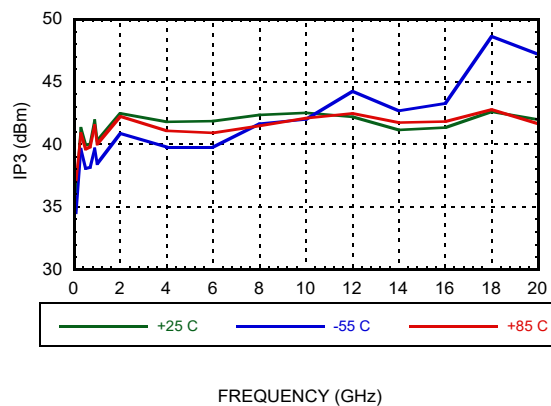

GaAs pHEMT SPDT NON-REFLECTIVE SWITCH, 0.1 - 20 GHz

Absolute Maximum Ratings

RF Input Power (Vctl = -5V)	+27 dBm
Control Voltage Range (A & B)	+0.5V to -7.5 Vdc
Channel Temperature	150 °C
Thermal Resistance (Insertion Loss Path)	118 °C/W
Thermal Resistance (Terminated Path)	200 °C/W
Storage Temperature	-65 to +150 °C
Operating Temperature	-55 to +85 °C
ESD Sensitivity (HBM)	Class 0 ; Passed 150 V

Control Voltages

State	Bias Condition
Low	0 to -0.2V @ 10 uA Max.
High	-5V@3uA Typ.to -7V@40uA Max.(+/-0.5Vdc)

Truth Table

Control Input		Signal Path State	
A	B	RFC to RF1	RFC to RF2
High	Low	ON	OFF
Low	High	OFF	ON



ELECTROSTATIC SENSITIVE DEVICE
OBSERVE HANDLING PRECAUTIONS

2

SWITCHES - CHIP

Outline Drawing

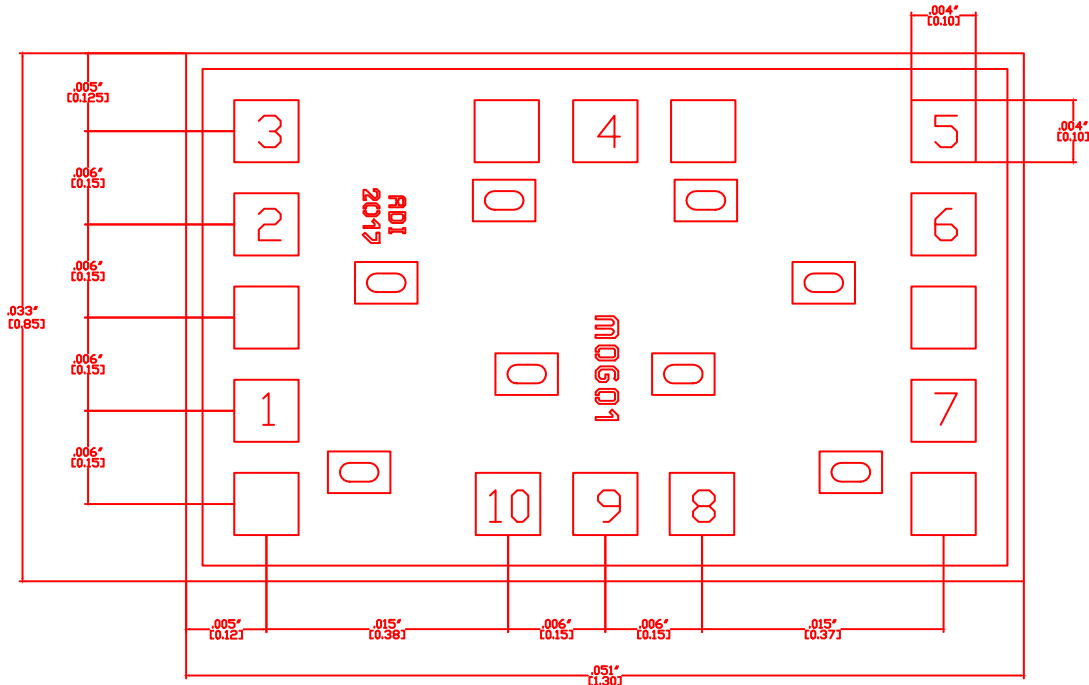

Die Packaging Information [1]

Standard	Alternate
WP-8 (Waffle Pack)	[2]

[1] Refer to the "Packaging Information" section for die packaging dimensions.

[2] For alternate packaging information contact Analog Devices Inc.

GaAs pHEMT SPDT NON-REFLECTIVE SWITCH, 0.1 - 20 GHz

Suggested Driver Circuit

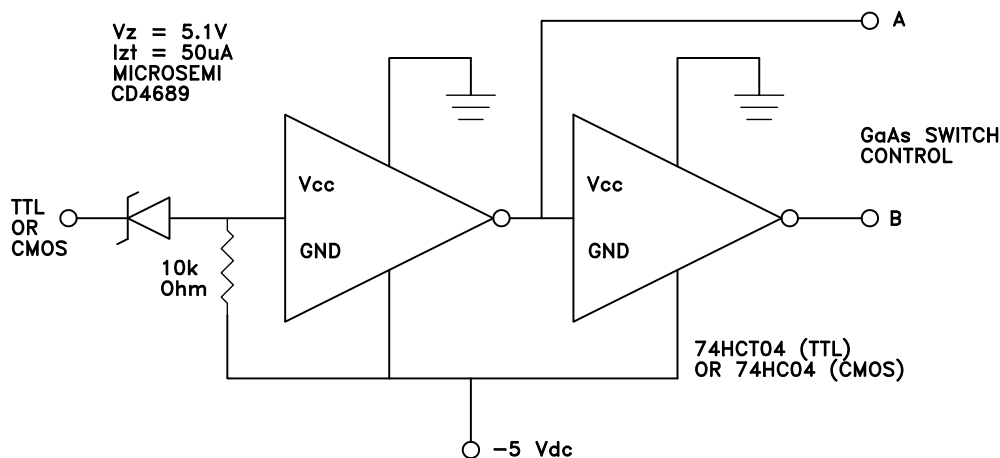

Pad Descriptions

Pad Number	Function	Description	Interface Schematic
1, 4, 7	RF1, RFC, RF2	This pad is DC coupled and matched to 50 Ohm. Blocking capacitors are required if the RF line potential is not equal to 0V.	
2, 5, 8, 10	CTRLA	See truth table and control voltage table.	
3, 6, 9	CTRLB	See truth table and control voltage table.	
	GND	Die bottom must be connected to RF ground.	

**GaAs pHEMT SPDT NON-REFLECTIVE
SWITCH, 0.1 - 20 GHz**

Assembly Diagram

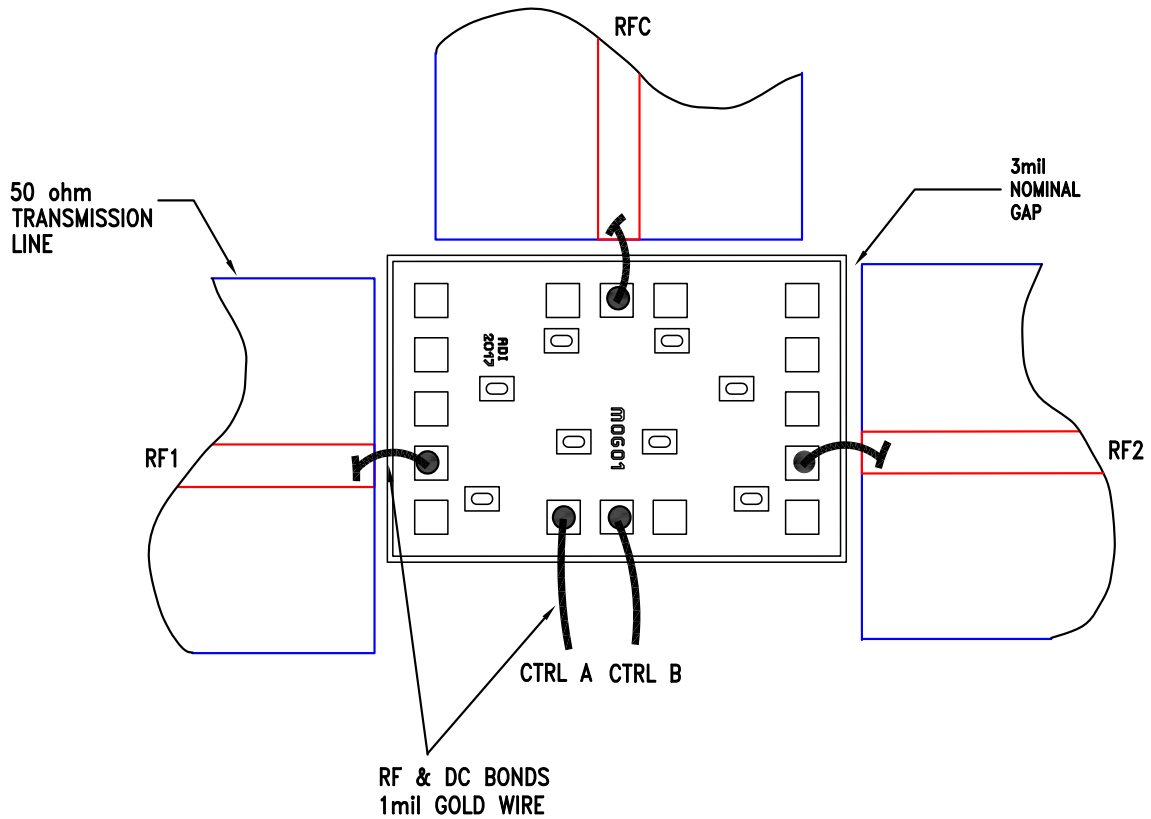

GaAs pHEMT SPDT NON-REFLECTIVE SWITCH, 0.1 - 20 GHz

Mounting & Bonding Techniques for Millimeterwave GaAs MMICs

The die should be attached directly to the ground plane eutectically or with conductive epoxy (see HMC general Handling, Mounting, Bonding Note).

50 Ohm Microstrip transmission lines on 0.127mm (5 mil) thick alumina thin film substrates are recommended for bringing RF to and from the chip (Figure 1). If 0.254mm (10 mil) thick alumina thin film substrates must be used, the die should be raised 0.150mm (6 mils) so that the surface of the die is coplanar with the surface of the substrate. One way to accomplish this is to attach the 0.102mm (4 mil) thick die to a 0.150mm (6 mil) thick molybdenum heat spreader (moly-tab) which is then attached to the ground plane (Figure 2).

Microstrip substrates should be brought as close to the die as possible in order to minimize bond wire length. Typical die-to-substrate spacing is 0.076mm (3 mils).

Handling Precautions

Follow these precautions to avoid permanent damage.

Storage: All bare die are placed in either Waffle or Gel based ESD protective containers, and then sealed in an ESD protective bag for shipment. Once the sealed ESD protective bag has been opened, all die should be stored in a dry nitrogen environment.

Cleanliness: Handle the chips in a clean environment. DO NOT attempt to clean the chip using liquid cleaning systems.

Static Sensitivity: Follow ESD precautions to protect against ESD strikes.

Transients: Suppress instrument and bias supply transients while bias is applied. Use shielded signal and bias cables to minimize inductive pick-up.

General Handling: Handle the chip along the edges with a vacuum collet or with a sharp pair of bent tweezers. The surface of the chip has fragile air bridges and should not be touched with vacuum collet, tweezers, or fingers.

Mounting

The chip is back-metallized and can be die mounted with AuSn eutectic preforms or with electrically conductive epoxy. The mounting surface should be clean and flat.

Eutectic Die Attach: A 80/20 gold tin preform is recommended with a work surface temperature of 255 deg. C and a tool temperature of 265 deg. C. When hot 90/10 nitrogen/hydrogen gas is applied, tool tip temperature should be 290 deg. C. DO NOT expose the chip to a temperature greater than 320 deg. C for more than 20 seconds. No more than 3 seconds of scrubbing should be required for attachment.

Epoxy Die Attach: Apply a minimum amount of epoxy to the mounting surface so that a thin epoxy fillet is observed around the perimeter of the chip once it is placed into position. Cure epoxy per the manufacturer's schedule.

Wire Bonding

Ball or wedge bond with 0.025 mm (1 mil) diameter pure gold wire (DC bias, IF1 and IF2) or Ribbon Bond (RF and LO ports) 0.076 mm x 0.013 mm (3 mil x 0.5 mil) size is recommended. Thermosonic wirebonding with a nominal stage temperature of 150 °C and a ball bonding force of 40 to 50 grams or wedge bonding force of 18 to 22 grams is recommended. Use the minimum level of ultrasonic energy to achieve reliable wirebonds. Wirebonds should be started on the chip and terminated on the package or substrate. All bonds should be as short as possible <0.31 mm (12 mils).

