



Chipsmall Limited consists of a professional team with an average of over 10 year of expertise in the distribution of electronic components. Based in Hongkong, we have already established firm and mutual-benefit business relationships with customers from,Europe,America and south Asia,supplying obsolete and hard-to-find components to meet their specific needs.

With the principle of “Quality Parts,Customers Priority,Honest Operation,and Considerate Service”,our business mainly focus on the distribution of electronic components. Line cards we deal with include Microchip,ALPS,ROHM,Xilinx,Pulse,ON,Everlight and Freescale. Main products comprise IC,Modules,Potentiometer,IC Socket,Relay,Connector.Our parts cover such applications as commercial,industrial, and automotives areas.

We are looking forward to setting up business relationship with you and hope to provide you with the best service and solution. Let us make a better world for our industry!



Contact us

Tel: +86-755-8981 8866 Fax: +86-755-8427 6832

Email & Skype: info@chipsmall.com Web: www.chipsmall.com

Address: A1208, Overseas Decoration Building, #122 Zhenhua RD., Futian, Shenzhen, China



HMC7150LP3DE

28 Gbps EML Driver

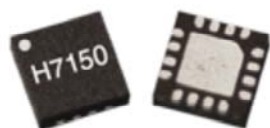

Data Rate (Gbps)	Function	Gain (dB)	Group Delay Variation (ps)	Additive Jitter (ps)	Output Voltage Max. (Vp-p)	Package
28.3	28 Gbps EML Driver	13	± 7	0.27	2.2	LP3D

Features

- Operation up to 28.3 Gbps
- Low DC Power Dissipation, 0.12W for 1.5Vpp swing @ 3.3V supply 0.50W for 2.3Vpp swing @ 6V supply
- Adjustable Output Amplitude from 1.2Vpp to 2.3Vp
- 16 Lead 3x3mm SMT Package: 9 mm²

Typical Applications

- 100Gb Ethernet ER4/ LR4 systems
- CFP/CFP2/CFP4 or similar form factor modules
- Optical transceivers and pluggable modules
- Broadband gain stages and pre-amplifiers
- Broadband Test & Measurement Equipment

Functional Diagram

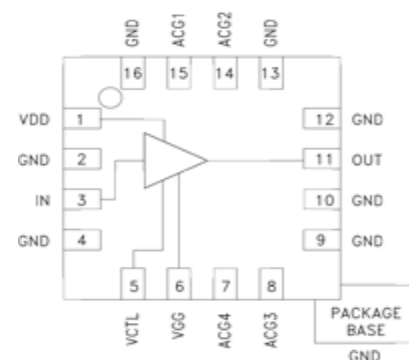

General Description

The HMC7150LP3DE is a broadband driver amplifier for electro-absorption modulated lasers (EML) and supports data-rates up to 28.3Gbps to meet the 100Gb Ethernet system requirements. The part provides the module designers scalable power dissipation for varying drive voltage characteristics of different modulators and the power consumption of the module can be set as low as 0.12W to 0.5W at 1.5Vpp and 2.3Vpp outputs amplitudes, respectively. The HMC7150LP3DE supports wide range of supply voltages from 3.3V to 6V and delivering excellent time domain performance. The output amplitude and cross-point can be adjusted via control pins. The input and output are 50 Ohms matched and used AC coupled. The HMC7150LP3DE is in compact leadless 3x3mm surface mountable package.