



Chipsmall Limited consists of a professional team with an average of over 10 year of expertise in the distribution of electronic components. Based in Hongkong, we have already established firm and mutual-benefit business relationships with customers from,Europe,America and south Asia,supplying obsolete and hard-to-find components to meet their specific needs.

With the principle of “Quality Parts,Customers Priority,Honest Operation,and Considerate Service”,our business mainly focus on the distribution of electronic components. Line cards we deal with include Microchip,ALPS,ROHM,Xilinx,Pulse,ON,Everlight and Freescale. Main products comprise IC,Modules,Potentiometer,IC Socket,Relay,Connector.Our parts cover such applications as commercial,industrial, and automotives areas.

We are looking forward to setting up business relationship with you and hope to provide you with the best service and solution. Let us make a better world for our industry!



Contact us

Tel: +86-755-8981 8866 Fax: +86-755-8427 6832

Email & Skype: info@chipsmall.com Web: www.chipsmall.com

Address: A1208, Overseas Decoration Building, #122 Zhenhua RD., Futian, Shenzhen, China



PRODUCT SELECTION GUIDE

Analog, Digital & Mixed-Signal ICs, Modules,
Subsystems & Instrumentation, DC - 110 GHz



Automotive

Telematics & Sensors

Broadband

Cable Modem, CATV, DBS & VoIP
WiMAX, WiBro, WLAN & UWB

Cellular Infrastructure

GSM, GPRS, CDMA, TD-SCDMA,
WCDMA, UMTS & 4G /LTE

Fiber Optics & Networking

OC-48 to 400G

Microwave & mmWave Communications

Backhaul Radio Links
Multi-Pt Radios & VSAT

Military

C³I, ECM & EW

Space

Payload Electronics

Test & Measurement

Commercial & Industrial Sensors
Test Equipment



Hittite Microwave Corporation is pleased to introduce our May 2013 Product Selection Guide summarizing over 1095 products including 22 new products. This selection guide organizes Hittite's portfolio by product line. Full specifications for each product are available at www.hittite.com. Click on "My Subscription" to receive the latest product releases.

General Information Page

Customer Support	3
Sales Contact Information	56

New Products

New & Expanded Product Lines

GaN Power Amplifiers	5, 7
GaAs MMIC SP4T Reflective Switch	5
I/Q Downconverter	6
Sub-Harmonic Mixers	6
28 Gbps EML Driver	26
Optical Modulator Drivers	26
Frequency Dividers	37

RF & Microwave ICs

Amplifiers	7
Attenuators	11
Automatic Gain Control	12
DC Power Conditioning	12
Filters - Tunable	12
IF / Baseband Processing	13
I/Q Mixers / IRMs	13
I/Q Downconverter / Receivers	14
I/Q Upconverter / Transmitters	14
Mixers	14
Modulators/Demodulators	17
Passives	18
Phase Shifters	18
Power Detectors	18
SDLVAs	18
Switches	18
Transceivers	19
Variable Gain Amplifiers	20

Analog & Mixed-Signal ICs

Broadband Time Delays	26
Comparators	27
Crosspoint Switch	27
Data Converters	27
DC Power Conditioning	28
DC Power Management	28
High Speed Digital Logic	29
IF / Baseband Processing	30
Interface	30
Limiting Amplifiers	30
Mux & Demux	30
Optical Modulator Drivers	30
Signal Conditioners	31
Transimpedance Amplifiers	31

Clock & Timing ICs Page

Clock Distribution	34
Clock Generators	34

LO Frequency Generation ICs

DC Power Conditioning	38
Filters - Tunable	38
Frequency Dividers & Detectors	38
Frequency Multipliers	38
Phase Locked Loop	39
PLL with Integrated VCOs	39
VCOs	40
PLOs	41

Connectorized Modules

Amplifiers	43
Attenuators	43
Dielectric Resonator Oscillators (DROs)	43
Frequency Dividers & Detectors	44
Frequency Multipliers	44
High Speed Digital Logic	44
I/Q Mixers	44
Mixers	44
Phase Shifters	44
SDLVAs	44
Switches	45
Synthesizer Module, MicroSynth®	45
VCOs	45

Instrumentation

Signal Generators	47
-------------------------	----

Market & Application Solutions

Automotive	21
Broadband	22
Cellular Infrastructure	22
Microwave & mmWave Communications, Test & Measurement & Sensors	25
Fiber Optics & Networking	32
Clock Generators for DC Clocking	34
Clock & Timing	35
LO Generation Applications	37

Military & Space Screening

Designer's Kits

Package Information

Part Number Index

How to Buy:

Hittite Microwave Corporation offers many convenient ways to order products and/or receive pricing and delivery information. Our order entry/MRP system assures customer sample requests and orders will be entered quickly, tracked easily, and completed accurately on-time.

Direct Sales

HMC Field Sales Offices:

You may contact our corporate or field sales offices listed on the back cover for assistance in purchasing Hittite products.

Purchase On-line: www.hittite.com

With Hittite Microwave's E-Commerce capability customers can enjoy the convenience of on-line ordering via a secure shopping cart interface. Products can be purchased using either a MasterCard, Visa, American Express or JCB card. Orders are confirmed within one business day with delivery information. Orders ship within 2 business days of confirmation, based on availability.

Purchase Orders via HMC Corporate Sales:

You may contact Hittite Microwave directly at (978) 250-3343. Purchase orders can be faxed to (978) 250-3373 or sent via email to sales@hittite.com. There is a minimum purchase order value of \$500.00 (U.S. Dollars).

Distributors

Digi-Key:

Tel: 1-800-344-4539, Email: www.digikey.com/ContactUs SalesInquiry or Web: www.digikey.com

Future Electronics:

Tel: 1-800-675-1619, Email: www.futureelectronics.com/ContactUs or Web: www.futureelectronics.com

Worldwide Network of Sales Representatives

You may purchase our products through our network of manufacturer representatives listed on the back cover.

• **European customers may also purchase products in Euros (€) directly from Hittite Microwave Deutschland GmbH (germany@hittite.com).**

• **Japanese customers may also purchase products in Yen (¥) directly from Hittite KK - Japan (japan@hittite.com).**

OUR QUALITY POLICY:

Hittite Microwave Corporation is Committed to:

- Being a supplier of products of the highest quality.
- Advancing state-of-the-art technology to support our products.
- Enhancing our competitive position with superior products.

Hittite's Quality Policy Recognizes

Responsibilities for Every Individual to:

- Take the initiative to promote quality.
- Create an environment where the highest quality standards are maintained.
- Participate in continuous improvement practices.

QUALITY & PRODUCT SUPPORT:

The Quality & Product Support Section of Our Web Site Includes:

- Quality Assurance - Product manufacturing, qualification & screening flows
- Product Reliability
- Qualification Test Reports

Product Application Support

- Application Engineering Support
- Application Notes
- Mixer Spur Chart Calculator, Parametric Search & PLL Phase Noise Calculator
- Product Cross Reference
- Package & Layout Drawings - Product outline, PCB land pattern and tape & reel drawings
- Published Papers
- S-Parameter Files

Data Sheets

- Complete product data sheets can be found on our web site.

HMC is ISO 9001:2008, AS9100-2009 and ANS/ESD S20.20-2007 certified. Every component is backed by every Hittite employee and subcontractor's commitment to total quality, thus providing our customers with products that meet or exceed all requirements, are delivered on-time and function reliability throughout their useful life.

WHAT WE DO

Hittite Microwave Corporation is an innovative designer and manufacturer of high performance integrated circuits (ICs), modules, subsystems and instrumentation for technically demanding digital, RF, microwave and millimeterwave applications covering DC to 110 GHz. The Company's standard and custom products apply analog, digital and mixed-signal semiconductor technologies, which are used in a wide variety of wireless / wired communication and sensor applications for Automotive, Broadband, Cellular Infrastructure, Fiber Optics & Networking, Microwave & Millimeterwave Communications, Military, Test & Measurement and Space markets. We offer over 1095 products across 36 product lines.

RF & Microwave ICs

Amplifiers
 Attenuators
 Automatic Gain Control
 DC Power Conditioning
 Filters - Tunable
 IF / Baseband Processing
 I/Q Mixers/IRMs
 I/Q Downconverter/Receivers
 I/Q Upconverters/Transmitters
 Mixers
 Modulators/Demodulators
 Passives
 Phase Shifters
 Power Detectors
 SDLVAs
 Switches
 Transceivers
 Variable Gain Amplifiers

Analog & Mixed-Signal ICs

Broadband Time Delays
 Comparators
 Crosspoint Switches
 Data Converters
 DC Power Conditioning
 DC Power Management
 High Speed Digital Logic
 IF/Baseband Processing
 Interface
 Limiting Amplifiers
 Mux & Demux

Optical Modulator Drivers
 Signal Conditioners
 Transimpedance Amplifiers

Clock & Timing ICs

Clock Distribution
 Clock Generators

LO Freq. Generation ICs

DC Power Conditioning
 Filters - Tunable
 Freq. Dividers & Detectors
 Freq. Multipliers
 Phase Locked Loop
 PLL with Integrated VCOs
 VCOs + PLOs

Connectorized Modules

Amplifiers
 Attenuators
 DROs
 Freq. Dividers & Detectors
 Freq. Multipliers
 High Speed Digital Logic
 I/Q Mixers
 Mixers
 Phase Shifters
 SDLVAs
 Switches
 Synthesizer Module, MicroSynth®
 VCOs

Instrumentation

Signal Generators to 70 GHz

We design and supply custom analog and digital ICs, modules, subsystems and instrumentation, combining multiple functions for specific requirements. We select the most appropriate semiconductor and package technologies, uniquely balancing digital and analog integration techniques.

Our custom and standard products support a wide range of wireless / wired communications & radar applications for the following markets:



Automotive
 Telematics & Sensors



Broadband
 CATV, DBS, WiBro, WiMAX,
 WLAN, Fixed Wireless & UW



Cellular Infrastructure
 GSM, GPRS, CDMA, WCDMA,
 UMTS, TD-SCDMA & 4G/LTE



Fiber Optic & Networking
 OC-48 to 400G



Microwave & mmWave Communications
 Backhaul Radio Links
 Multi-PT Radios & VSAT



Military
 C-I, ECM & EW



Space
 Payload Electronics



Test & Measurement
 Commercial / Industrial
 Sensors & Test Equipment

AMPLIFIERS

GaN Power Amplifiers

Frequency (GHz)	Function	Gain (dB)	OIP3 (dBm)	Psat (dB)	Power Gain @ Psat (dB)	Bias Supply	Package	ECCN Code	Part Number
2 - 6	GaN MMIC Power Amplifier, 25W	22	+48	44.5	14	+28V @ 1100 mA	Chip	ITAR	HMC1086
2 - 6	GaN MMIC Flange Mount Power Amplifier, 25W	23	+46	44.5	11	+28V @ 1100 mA	F10	ITAR	HMC1086F10
2 - 20	GaN MMIC Power Amplifier, 8W	11	+45	39	5.5	+28V @ 850 mA	Chip	ITAR	HMC1087
2 - 20	GaN MMIC Flange Mount Power Amplifier, 8W	11	+43.5	38.5	6.5	+28V @ 850 mA	F10	ITAR	HMC1087F10

Linear & Power Amplifiers

Frequency (GHz)	Function	Gain (dB)	OIP3 (dBm)	NF (dB)	P1dB (dBm)	Bias Supply	Package	ECCN Code	Part Number
6 - 18	Medium Power Amplifier, 0.5 Watt	22	+35	-	25	+5V @ 220mA	LP4	EAR99	HMC1082LP4E
15 - 20	Power Amplifier, 2 Watt	26	+43.5	-	33.5	+6V @ 1100mA	LS6	3A001.b.2.c	HMC6981LS6
37 - 40	Power Amplifier, 1 Watt	22	+38	-	30	+6V @ 960mA	LS6	3A001.b.2.d	HMC7229LS6

DATA CONVERTERS

Low Power Analog-to-Digital Converters

Sample Rate (MSPS)	Function / Mode	Resolution (bits)	# of Channels	Power Dissipation	SNR (dBFS)	SFDR (dBc)	Package	ECCN Code	Part Number
80 / 105 / 125	Quad Channel	14	4	490 / 605 / 765 mW	74	85	LP7DE	3A991.c.3	HMCAD1062
80 / 105 / 125	Dual Channel	14	2	300 / 380 / 460 mW	74	85	LP7DE	3A991.c.3	HMCAD1062B
400	Dual Channel	14	2	750 mW / Channel	72	85	LG9E / LP9E	3A001.a.5.a.4	HMCAD1063
400	Dual Channel	16	2	1100 mW / Channel	76	90	LG9E	3A001.a.5.a.5	HMCAD1073

Track-and-Hold Amplifier

Input Frequency (GHz)	Function	Single Tone THD/SFDR (dB)	Maximum Clock Rate (GSPS)	Output Noise (mV RMS)	Hold Mode Feedthrough Rejection (dB)	Package	ECCN Code	Part Number
18	Dual Rank Track-and-Hold	55 / 56	4	1.4	>65	LC5	3A001.a.11.b	HMC1061LC5

FREQUENCY DIVIDERS (PRESCALERS) & DETECTORS

Input Frequency (GHz)	Function	Input Power (dBm)	Output Level (dBm)	Floor FOM (dBc/Hz)	Bias Supply	Package	ECCN Code	Part Number
0.01 - 3	Integer-N (2 - 32) PLL	-10 to +5	2 Vp-p	-155 (@ Fref = 100 MHz)	+5V @ 290mA	LP4	3A001.a.11.b	HMC873LP4E
0.01 - 3	Phase Frequency Detector w/ Lock Det. & Invert Function	-10 to +5	2 Vp-p	-155 (@ Fref = 100 MHz)	+5V @ 120mA	LP4	3A001.a.11.b	HMC872LP4E
0.01 - 3	6-Bit Counter (N = 2 - 64)	-10 to +5	2 dBm	-160 (@ Fin = 100 MHz, N = 2)	+5V @ 200mA	LP4	3A001.a.11.b	HMC879LP4E

I/Q MIXERS / IRMS - I/Q Downconverter / Receiver

RF Frequency (GHz)	Function	IF Frequency (GHz)	Conversion Gain (dB)	Noise Figure (dB)	Image Rejection (dBc)	IIP3 (dBm)	Package	ECCN Code	Part Number
27 - 34	I/Q Downconverter / Receiver	DC - 4	12	3	17	2	LP4	EAR99	HMC1065LP4E

MIXERS

Single, Double & Triple Balanced

RF Frequency (GHz)	Function	IF Frequency (GHz)	Conversion Gain (dB)	LO / RF Isolation (dB)	IIP3 (dBm)	Package	ECCN Code	Part Number
50 - 75	Double Balanced Mixer	DC - 26	-7.5	30	16	Chip	EAR99	HMC1081

Sub-Harmonic Mixer

RF Frequency (GHz)	Function	IF Frequency (GHz)	Conversion Gain (dB)	LO / RF Isolation (dB)	IIP3 (dBm)	Package	ECCN Code	Part Number
71 - 86	Sub-Harmonic	DC - 12	-11	28	6	Chip	EAR99	HMC1058

OPTICAL MODULATOR DRIVERS

Data Rate Max. (Gbps)	Function	Gain (dB)	Group Delay Variation (ps)	Additive Jitter (ps)	Output Voltage Max. (Vp-p)	Package	ECCN Code	Part Number
28.3	EML Driver	11	±7	0.27	2.2	LP3D	EAR99	HMC7150LP3DE
32	Optical Modulator Driver, Pre-Stage	15	±5	0.3	3	Chip	EAR99	HMC1068
32	Optical Modulator Driver	15	±5	0.3	7.5	Chip	EAR99	HMC1069

SWITCHES

Frequency (GHz)	Function	Insertion Loss (dB)	Isolation (dB)	Input P1dB (dBm)	Control Input (Vdc)	Package	ECCN Code	Part Number
28 - 30	SP4T	2.8	26	-	0 / -3V	LC4	EAR99	HMC1084LC4

GaN 25W Power Amplifier 2 to 6 GHz

NEW!



HMC1086



HMC1086F10

Features

- ◆ High Output Power: +45 dBm
- ◆ High Output IP3: +48 dBm
- ◆ Small Signal Gain: 22 dB
- ◆ +28V @ 1.1 A

GaN 8W Power Amplifier 2 to 20 GHz

NEW!



HMC1087

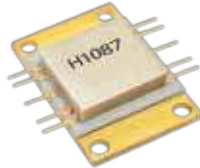

HMC1087F10

Features

- ◆ High Output Power: +39 dBm
- ◆ High Output IP3: +45 dBm
- ◆ Small Signal Gain: 11 dB
- ◆ +28V @ 850 mA

GaN Power Amplifiers for General Communications, Test Instrumentation, and Radar Applications.

HMC1084LC4 - GaAs MMIC SP4T Reflective Switch, 23 - 30 GHz

NEW!

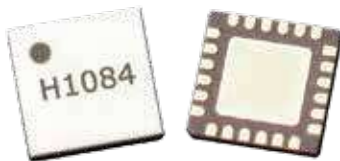

Features

- ◆ Broadband Performance: 23 - 30 GHz
- ◆ High Isolation: 26 dB
- ◆ Insertion Loss: 2.8 dB
- ◆ High Power Handling: >27 dBm
- ◆ 24 Lead 4x4mm SMT Package: 16mm²

Insertion Loss RFIN to RF1 vs. Temperature

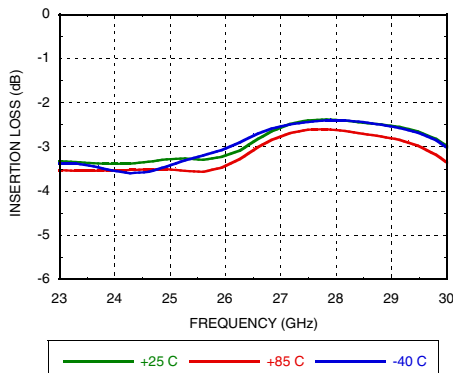

Input IP3 vs. Temperature @ 10 dBm/tone

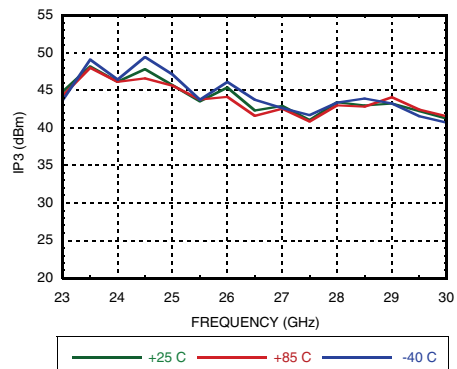

Ideal for Microwave Radio, Satcom, & Sensor Applications.

New & Expanded Product Lines

HMC1065LP4E - I/Q Downconverter, 27 - 34 GHz

NEW!



24 Lead 4 x 4 SMT Package

Conversion Gain vs. Temperature, USB

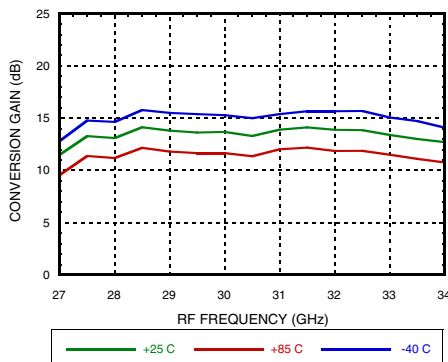

Features

- ◆ High Conversion Gain: 13 dB
- ◆ Excellent Image Rejection: 17 dBc
- ◆ High Input IP3: +2 dBm
- ◆ High 2LO/RF Isolation: 45 dB

2LO Isolation

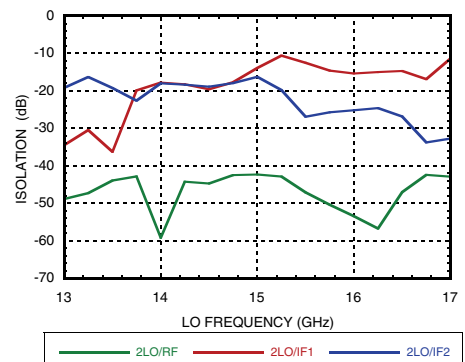

Ideal for Point-to-Point and Point-to-Multi-Point Radio.

HMC1057 & HMC1058 - Sub-Harmonic MMIC Mixers, 71 - 86 GHz

NEW!

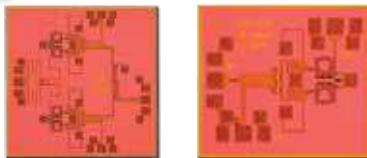

HMC1057

HMC1058

**Conversion Gain, USB vs. Temperature
LO = 4 GHz, USB**

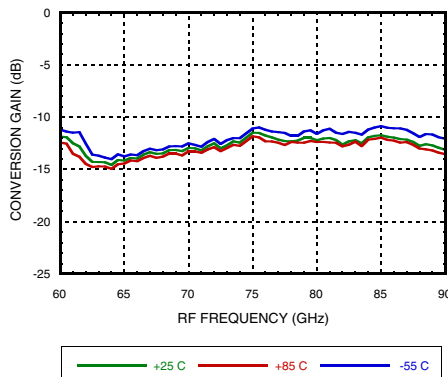

Features

- ◆ Passive: No DC Bias Required
- ◆ Wide IF Bandwidth: DC to 12 GHz
- ◆ High LO/RF Isolation: up to 30 dB
- ◆ High 2LO/RF Isolation: up to 50 dB
- ◆ Upconversion & Downconversion Applications

Image Rejection, USB vs. LO Power

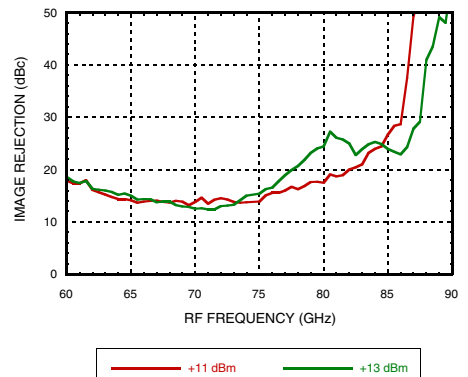

Amplifier & Mixer Solutions for Backhaul Radios to 90 GHz.

AMPLIFIERS

Frequency (GHz)	Function	Gain (dB)	OIP3 (dBm)	Psat (dB)	Power Gain @ Psat (dB)	Bias Supply	Package	ECCN Code	Part Number
GaN Power Amplifiers									
0.01 - 10	GaN MMIC Power Amplifier, 10W	11	+47	40	+5.5	+48V @ 1100 mA	Chip	3A001.b.2.b	HMC999
NEW! 2 - 6	GaN MMIC Power Amplifier, 25W	22	+48	44.5	14	+28V @ 1100 mA	Chip	ITAR	HMC1086
NEW! 2 - 6	GaN MMIC Flange Mount Power Amplifier, 25W	23	+46	44.5	11	+28V @ 1100 mA	F10	ITAR	HMC1086F10
NEW! 2 - 20	GaN MMIC Power Amplifier, 8W	11	+45	39	5.5	+28V @ 850 mA	Chip	ITAR	HMC1087
NEW! 2 - 20	GaN MMIC Flange Mount Power Amplifier, 8W	11	+43.5	38.5	6.5	+28V @ 850 mA	F10	ITAR	HMC1087F10

AMPLIFIERS

Frequency (GHz)	Function	Gain (dB)	OIP3 (dBm)	NF (dB)	P1dB (dBm)	Bias Supply	Package	ECCN Code	Part Number
Low Noise Amplifiers									
0.175 - 0.66	Low Noise	24	37	0.5	19	+5V @ 90 mA	LP3	EAR99	HMC616LP3E
0.23 - 0.66	Low Noise, Dual Channel	22	37	0.5	19	+5V @ 97 mA	LP4	EAR99	HMC816LP4E
0.3 - 3.0	Low Noise, High IP3	15	37	1.5	22	+5V @ 90 mA	SOT26	EAR99	HMC374E
0.3 - 3.0	Low Noise Amplifier	15	35	1.6	17	+3.3V @ 75 mA	SC70	EAR99	HMC374SC70E
0.55 - 1.2	Low Noise	16	37	0.5	21	+5V @ 88 mA	LP5	EAR99	HMC617LP3E
0.55 - 1.2	Low Noise, Dual Channel	16	37	0.5	20.5	+5V @ 95 mA	LP4	EAR99	HMC817LP4E
0.6 - 1.4	Low Noise	32	40	0.9	21.5	+5V @ 254 mA	LP4	EAR99	HMC718LP4E
0.7 - 1.2	Low Noise with Failsafe Bypass	16	33	0.9	13	+5V @ 57 mA	LP3	EAR99	HMC668LP3E
0.7 - 2.2	Low Noise	22	36	1.7	24	+5V @ 227 mA	LP3	EAR99	HMC758LP3E
1 - 11	Low Noise	17	30	1.5	18	+5V @ 55 mA	LP4	EAR99	HMC753LP4E [1]
1 - 12	Low Noise	17	28	1.5	19	+5V @ 55 mA	Chip	EAR99	HMC-ALH444 [1]
1.2 - 3.0	Low Noise	26	21	1.3	11.5	+5V @ 21 mA	LP3	EAR99	HMC548LP3E
1.3 - 2.9	Low Noise	34	39	1	21.5	+5V @ 272 mA	LP4	EAR99	HMC719LP4E
1.7 - 2.2	Low Noise	19	36	0.75	20	+5V @ 117 mA	LP3	EAR99	HMC618LP3E
1.7 - 2.2	Low Noise with Failsafe Bypass	17	29	1.4	12	+5V @ 86 mA	LP3	EAR99	HMC669LP3E
1.7 - 2.2	Low Noise, Dual Channel	20.5	35	0.85	21	+5V @ 112 mA	LP4	EAR99	HMC818LP4E
2 - 12	Low Noise	15	25	1.8	13	+4V @ 45 mA	LC4	EAR99	HMC772LC4 [1]
2.1 - 2.9	Low Noise	19	33	0.9	19	+5V @ 95 mA	LP3	EAR99	HMC715LP3E
2.3 - 2.5	Low Noise	19	12	1.7	6	+3V @ 8.5 mA	SOT26	EAR99	HMC286E
2.3 - 2.7	Low Noise	19	29.5	0.75	16.5	+5V @ 59 mA	LP2	EAR99	HMC667LP2E
2.3 - 2.7	Low Noise with Bypass	20	31	1.1	17	+5V @ 74 mA	LP3	EAR99	HMC605LP3E
2.4 - 2.5	Transceiver, Front End	13	10	3	5	+3V @ 24 mA	MS8G	EAR99	HMC310MS8GE
3.1 - 3.9	Low Noise	18	33	1	19	+5V @ 65 mA	LP3	EAR99	HMC716LP3E
3.3 - 3.8	Low Noise with Bypass	19	29	1.2	16	+5V @ 40 mA	LP3	EAR99	HMC593LP3E
3.4 - 3.8	Low Noise with Bypass	16	18	2	7	+3V @ 9 mA	LP3	EAR99	HMC491LP3E
3.5 - 7.0	Low Noise	15.5	28	2.4	16	+5V @ 50 mA	Chip	EAR99	HMC392
3.5 - 7.0	Low Noise	16	30	2.5	16	+5V @ 55 mA	LC4	EAR99	HMC392LC4
3.5 - 7.0	Low Noise	15	28	3	16	+5V @ 65 mA	LH5	EAR99	HMC392LH5
4.8 - 6.0	Low Noise with Bypass	15	26	1.5	14	+5V @ 42 mA	LP3	EAR99	HMC604LP3E
4.8 - 6.0	Low Noise	16.5	31.5	1.1	18.5	+5V @ 73 mA	LP3	EAR99	HMC717LP3E
5 - 6	Low Noise	9	13	2.5	2	+3V @ 6 mA	MS8G	EAR99	HMC318MS8GE
5 - 6	Low Noise	12	10	2.5	9	+3V @ 25 mA	MS8G	EAR99	HMC320MS8GE
5 - 10	Low Noise	20	28	1.7	16	+3.5V @ 80 mA	Chip	EAR99	HMC902
5 - 10	Low Noise	19	28	1.8	16	+3.5V @ 80 mA	LP3	EAR99	HMC902LP3E
5 - 20	Low Noise	13	26	2.2	16	+5V @ 30 mA	Chip	EAR99	HMC-ALH435 [1]
6 - 17	Low Noise	18	25	1.7	14	+3.5V @ 80 mA	LP3	EAR99	HMC903LP3E
6 - 18	Low Noise	19	26	1.6	15	+3.5V @ 80 mA	Chip	EAR99	HMC903
6 - 20	Low Noise	22	20	2.3	10	+3V @ 53 mA	Chip	EAR99	HMC565
6 - 20	Low Noise	21	20	2.5	10	+3V @ 53 mA	LC5	EAR99	HMC565LC5
6 - 26.5	Low Noise	22	18	2.5	10	+3.5V @ 45 mA	LC4	EAR99	HMC963LC4
7 - 13.5	Low Noise	17	24	1.8	12	+3V @ 51 mA	Chip	EAR99	HMC564
7 - 14	Low Noise	17	25	1.8	13	+3V @ 51 mA	LC4	EAR99	HMC564LC4
7 - 17	Low Noise	21	20	1.8	15	+3V @ 65 mA	Chip	EAR99	HMC516
7.5 - 26.5	Low Noise	13	23	2.5	13	+3.5V @ 70 mA	LC4	EAR99	HMC962LC4
9 - 18	Low Noise	20	25	2	14	+3V @ 65 mA	LC5	EAR99	HMC516LC5
12 - 16	Medium Power LNA	23	34	2.5	25	+5V @ 200 mA	LP5	EAR99	HMC490LP5E [1]
12 - 17	Medium Power LNA	27	35	2	26	+5V @ 200 mA	Chip	EAR99	HMC490 [1]
13 - 25	Low Noise	21	13	3.5	5	+3V @ 41 mA	Chip	EAR99	HMC342
13 - 25	Low Noise	22	20	3.5	9	+3V @ 43 mA	LC4	EAR99	HMC342LC4
14 - 27	Low Noise	19.5	-	2.2	17	+4V @ 90 mA	LC4B	5A991.h	HMC504LC4B

[1] Amplifiers that benefit from Hittite Active Bias Controllers

SMT & Chip (Die) Products
AMPLIFIERS

Frequency (GHz)	Function	Gain (dB)	OIP3 (dBm)	NF (dB)	P1dB (dBm)	Bias Supply	Package	ECCN Code	Part Number
14 - 27	Low Noise	18	-	2.5	14	+4V @ 90 mA	Chip	5A991.h	HMC-ALH216 [1]
14 - 27	Low Noise	20	-	2	14	+4V @ 90 mA	Chip	5A991.h	HMC-ALH476 [1]
17 - 26	Low Noise	19	23	2.2	11	+3V @ 65 mA	Chip	EAR99	HMC517
17 - 26	Low Noise	19	23	2.5	13	+3V @ 67 mA	LC4	EAR99	HMC517LC4
17 - 27	Low Noise	25	25	2.2	13	+4V @ 73 mA	LC4	EAR99	HMC751LC4
18 - 31	Low Noise	15	23	3.5	11	+3V @ 75 mA	LC4	EAR99	HMC519LC4
18 - 32	Low Noise	15	23	2.8	12	+3V @ 65 mA	Chip	3A001.b.2.d	HMC519
18 - 40	Low Noise	10	-	3.9	12	+5V @ 45 mA	Chip	3A001.b.2.d	HMC-ALH445
20 - 32	Low Noise	15	23	3	12	+3V @ 65 mA	Chip	3A001.b.2.d	HMC518
21 - 29	Low Noise	13	19	2.5	8	+3V @ 35 mA	LC3B	EAR99	HMC341LC3B
22 - 26.5	Low Noise	25	-	3	12	+2.5V @ 52 mA	Chip	5A991.h	HMC-ALH311 [1]
24 - 28	Low Noise	25	26	2.5	13	+3V @ 70 mA	LC4	EAR99	HMC752LC4 [1]
24 - 30	Low Noise	13	16	2.5	6	+3V @ 30 mA	Chip	EAR99	HMC341
24 - 32	Low Noise	21	-	2	7	+5V @ 68 mA	Chip	3A001.b.2.d	HMC-ALH364
24 - 36	Low Noise	23	17	2	8	+3V @ 58 mA	Chip	3A001.b.2.d	HMC263
24 - 36	Low Noise	20	18	2.2	8	+3V @ 58 mA	LP4	3A001.b.2.d	HMC263LP4E
24 - 40	Low Noise	12	-	3.5	13	+4V @ 45 mA	Chip	3A001.b.2.d	HMC-ALH244
24 - 40	Low Noise	22	-	2	11	+5V @ 66 mA	Chip	3A001.b.2.d	HMC-ALH369
24 - 40	Low Noise	11.5	-	4	15	+4V @ 60 mA	Chip	3A001.b.2.d	HMC-ALH140 [1]
24 - 43.5	Low Noise	22	22	2.7	12	+2.5V @ 70 mA	LP3C	3A001.b.2.d	HMC1040LP3CE
27 - 33	Low Noise	20	-	3	12	+2.5V @ 52 mA	Chip	3A001.b.2.d	HMC-ALH313 [1]
28 - 36	Low Noise	21	24	2.8	12	+3V @ 82 mA	LP4	3A001.b.2.d	HMC566LP4E
29 - 36	Low Noise	20	23.5	2.8	12	+3V @ 80 mA	Chip	3A001.b.2.d	HMC566
35 - 45	Low Noise	16	-	2	6	+4V @ 87 mA	Chip	3A001.b.2.d	HMC-ALH376
37 - 42	Low Noise	22	-	3.5	12	+2.5V @ 52 mA	Chip	3A001.b.2.d	HMC-ALH310 [1]
57 - 65	Low Noise	21	-	4	12	+2.5V @ 64 mA	Chip	3A001.b.2.f	HMC-ALH382 [1]
71 - 86	Low Noise	13	-	5	7	+2.4V @ 30 mA	Chip	3A001.b.2.f	HMC-ALH508
71 - 86	Low Noise	14	-	5	7	+2V @ 50 mA	Chip	3A001.b.2.f	HMC-ALH509

Broadband Gain Blocks (Listed by P1dB Output Power)

DC - 6	SiGe Gain Block	15.5	22	3	8	+5V @ 25 mA	MP86	EAR99	HMC474MP86E
DC - 6	SiGe Gain Block	15	20	3	8	+3V @ 25 mA	SC70	EAR99	HMC474SC70E
DC - 6	SiGe Gain Block	20	25	2.5	12	+5V @ 35 mA	MP86	EAR99	HMC476MP86E
DC - 6	SiGe Gain Block	19	24	2.5	12	+5V @ 35 mA	SC70	EAR99	HMC476SC70E
DC - 10	HBT Gain Block	15	24	4.5	13	+5V @ 56 mA	Chip	EAR99	HMC397
DC - 10	HBT Gain Block	15	25	4	13	+5V @ 50 mA	Chip	EAR99	HMC405
DC - 6	HBT Gain Block	17	27	6.5	14	+5V @ 50 mA	SOT26	EAR99	HMC313E
DC - 8	HBT Gain Block	12	30	6	14	+5V @ 56 mA	Chip	EAR99	HMC396
DC - 4	HBT Gain Block	15	28	4.5	15	+5V @ 54 mA	Chip	EAR99	HMC395
DC - 8	HBT Gain Block	15	30	5	15	+5V @ 54 mA	SC70	EAR99	HMC311SC70E
DC - 6	HBT Gain Block	14.5	32	4.5	15.5	+5V @ 56 mA	LP3	EAR99	HMC311LP3E
DC - 6	HBT Gain Block	16	31.5	4.5	15.5	+5V @ 54 mA	ST89	EAR99	HMC311ST89E
DC - 4	SiGe Gain Block	24	31	2.5	17	+5V @ 62 mA	SC70	EAR99	HMC478SC70E
DC - 4	SiGe Gain Block	22	32	2	18	+5V @ 62 mA	MP86	EAR99	HMC478MP86E
DC - 4	SiGe Gain Block	22	33	3	18	+5V @ 62 mA	ST89	EAR99	HMC478ST89E
DC - 5	SiGe Gain Block	15	34	4	18	+8V @ 72 mA	MP86	EAR99	HMC479MP86E
DC - 5	SiGe Gain Block	15	34	4	18	+8V @ 75 mA	ST89	EAR99	HMC479ST89E
DC - 5	Dual SiGe Gain Block	15	34	4	18	+8V @ 75 mA	MS8G	EAR99	HMC469MS8GE
DC - 5	SiGe Gain Block	20	33	3.5	19	+8V @ 79 mA	ST89	EAR99	HMC481ST89E
DC - 10	pHEMT Gain Block	14	30	7	20	+5V @ 76 mA	LP2	EAR99	HMC788LP2E
DC - 5	SiGe Gain Block	19	34	2.9	20	+8V @ 82 mA	ST89	EAR99	HMC480ST89E
DC - 5	SiGe Gain Block	20	33	3.5	20	+8V @ 74 mA	MP86	EAR99	HMC481MP86E
DC - 5	Dual SiGe Gain Block	20	34	3.2	20	+8V @ 80 mA	MS8G	EAR99	HMC471MS8GE
DC - 4	HBT Gain Block	21	33	4	21	+5V @ 82 mA	ST89	EAR99	HMC589ST89E
0.2 - 4.0	Low Noise, High IP3, pHEMT Gain Block	13	38	2.3	22	+5V @ 110 mA	ST89	EAR99	HMC639ST89E
0.2 - 4.0	Low Noise, High IP3, pHEMT Gain Block	13	40	2.2	22	+5V @ 155 mA	ST89	EAR99	HMC636ST89E
DC - 1	HBT Gain Block	22	37	2.8	22	+5V @ 88 mA	ST89	EAR99	HMC580ST89E
DC - 4.5	HBT Gain Block	21	35	3.5	22	+8V @ 110 mA	ST89	EAR99	HMC475ST89E
DC - 5	SiGe Gain Block	19	36	4	22	+8V @ 110 mA	ST89	EAR99	HMC482ST89E
7 - 15	HBT Gain Block	15	28	4	15	+5V @ 44 mA	LP3B	EAR99	HMC3653LP3BE

[1] Amplifiers that benefit from Hittite Active Bias Controllers

AMPLIFIERS

Frequency (GHz)	Function	Gain (dB)	OIP3 (dBm)	NF (dB)	P1dB (dBm)	Bias Supply	Package	ECCN Code	Part Number
CATV Amplifiers									
0.04 - 0.96	Low Noise, Dual Output	5	27	3.5	12	+5V @ 120 mA	MS8G	EAR99	HMC549MS8GE
0.05 - 1.0	Low Noise, 75 Ohm	14	39	2.2	19	+5V @ 120 mA	ST89	EAR99	HMC599ST89E
0.04 - 1.0	50 / 75 Ohm Differential Gain Block	16	40	2.5	23.5	+5V @ 270 mA	LP4B	EAR99	HMC770LP4BE
0.05 - 3.0	HBT Gain Block	15	40	3.5	18	+5V @ 88 mA	ST89	EAR99	HMC740ST89E
0.05 - 3.0	HBT Gain Block	20	42	2.5	18.5	+5V @ 96 mA	ST89	EAR99	HMC741ST89E
DC - 1	HBT Gain Block, 75 Ohm	14	38	5.5	21	+5V @ 160 mA	S8G	EAR99	HMC754S8GE
Driver Amplifiers									
0.7 - 2.8	HBT Driver Amplifier	18	42	3.8	25	+5V @ 125 mA	ST89	EAR99	HMC789ST89E
0.8 - 3.8	Driver Amplifier	18	30	7.5	17	+5V @ 53 mA	SOT26	EAR99	HMC308E
3.0 - 4.5	HBT Driver Amplifier	21	36	5	23.5	+5V @ 130 mA	MS8G	EAR99	HMC326MS8GE
17.5 - 41	Driver Amplifier	21	27	-	20	+5V @ 295 mA	Chip	3A001.b.2.d	HMC-AUH256
Linear & Power Amplifiers									
0.4 - 2.5	High IP3 Amp, 1/2 Watt	12.5	42	6	27	+5V @ 150 mA	ST89	EAR99	HMC454ST89E
1.6 - 2.2	Medium Power Amplifier	22	40	5.5	27	+3.6V @ 270 mA	QS16G	EAR99	HMC413QS16GE
5 - 6	Medium Power Amplifier	17	38	6	26	+5V @ 300 mA	MS8G	EAR99	HMC406MS8GE
5 - 7	Medium Power Amplifier	15	40	5.5	25	+5V @ 230 mA	MS8G	EAR99	HMC407MS8GE
5 - 18	Medium Power Amplifier	18	28	7	19.5	+5V @ 120 mA	LP3	EAR99	HMC451LP3E
5 - 20	Medium Power Amplifier	22	30	6.5	20	+5V @ 127 mA	Chip	EAR99	HMC451
5 - 20	Medium Power Amplifier	19	30	7	19	+5V @ 114 mA	LC3	EAR99	HMC451LC3
6 - 18	Medium Power Amplifier	15.5	32	4.5	20	+5V @ 95 mA	Chip	EAR99	HMC441
6 - 18	Medium Power Amplifier	17	32	4.5	20	+5V @ 95 mA	LC3B	EAR99	HMC441LC3B
NEW! 6 - 18	Medium Power Amplifier, 0.5 Watt	22	+35	-	25	+5V @ 220 mA	LP4E	EAR99	HMC1082LP4E
6.5 - 13.5	Medium Power Amplifier	14	29	4.5	18	+5V @ 95 mA	LP3	EAR99	HMC441LP3E
7 - 15.5	Medium Power Amplifier	15	32	4.8	20	+5V @ 95 mA	LH5 Hermetic	EAR99	HMC441LH5
7 - 15.5	Medium Power Amplifier	16	30	4.5	19	+5V @ 90 mA	LM1	EAR99	HMC441LM1
9.5 - 11.5	Medium Power Amplifier	29.5	33	6	27	+5V @ 310 mA	LC4	EAR99	HMC608LC4
12 - 30	Medium Power Amplifier	16	25	7	16	+5V @ 101 mA	Chip	EAR99	HMC383
12 - 30	Medium Power Amplifier	15	25	7.5	16.5	+5V @ 100 mA	LC4	EAR99	HMC383LC4
16 - 33	Medium Power Amplifier	17	33	-	24	+5V @ 400 mA	Chip	5A991.h	HMC-APH596
17 - 24	Medium Power Amplifier	24	34	4	25	+5V @ 250 mA	Chip	EAR99	HMC498
17 - 24	Medium Power Amplifier	22	36	4	25	+5V @ 250 mA	LC4	EAR99	HMC498LC4
17 - 30	Medium Power Amplifier	20	31	-	22	+4.5V @ 400 mA	Chip	5A991.h	HMC-APH196
17.5 - 24	Medium Power Amplifier	14	28	6.5	21.5	+5V @ 85 mA	LM1	EAR99	HMC442LM1
17.5 - 25.5	Medium Power Amplifier	15	28	5.5	22	+5V @ 85 mA	Chip	EAR99	HMC442 [1]
17.5 - 25.5	Medium Power Amplifier	13	27	8	22	+5V @ 84 mA	LC3B	EAR99	HMC442LC3B [1]
21 - 32	Medium Power Amplifier	16	33	5	24	+5V @ 200 mA	Chip	3A001.b.2.d	HMC499 [1]
21 - 32	Medium Power Amplifier	17	34	5	23	+5V @ 200 mA	LC4	3A001.b.2.d	HMC499LC4 [1]
33.5 - 46.5	Medium Power Amplifier, 0.5 Watt	21	35	-	24.5	+6V @ 500 mA	Chip	3A001.b.2.d	HMC1014
34 - 42	Medium Power Amplifier	18.5	29	6.5	18	+5V @ 120 mA	Chip	3A001.b.2.d	HMC-ABH264 [1]
34 - 46.5	Medium Power Amplifier	22	34	-	24	+6V @ 250 mA	Chip	3A001.b.2.f	HMC1016
37 - 40	Medium Power Amplifier	20	35	-	26	+5V @ 640 mA	Chip	3A001.b.2.d	HMC-APH510
37 - 45	Medium Power Amplifier	21	32	-	23	+5V @ 475 mA	Chip	3A001.b.2.d	HMC-APH403
50 - 66	Medium Power Amplifier	24	25	-	17	+5V @ 220 mA	Chip	3A001.b.2.f	HMC-ABH241
55 - 65	Medium Power Amplifier	13	25	-	16	+5V @ 80 mA	Chip	3A001.b.2.f	HMC-ABH209 [1]
71 - 76	Medium Power Amplifier	24	-	-	17.5	+4V @ 130 mA	Chip	3A001.b.2.f	HMC-AUH318 [1]
71 - 76	Medium Power Amplifier	13	-	-	20	+4V @ 240 mA	Chip	3A001.b.2.f	HMC-APH633
71 - 86	Medium Power Amplifier	15	-	-	15	+4V @ 130 mA	Chip	3A001.b.2.f	HMC-AUH320 [1]
81 - 86	Medium Power Amplifier	22	-	-	17.5	+4V @ 160 mA	Chip	3A001.b.2.f	HMC-AUH317 [1]
81 - 86	Medium Power Amplifier	12	-	-	19	+4V @ 240 mA	Chip	3A001.b.2.f	HMC-APH634
0.01 - 10	GaN Power Amplifier, 10 Watt	11	47	-	38	+48V @ 1100 mA	Chip	3A001.b.2.b	HMC999
0.1 - 22	Power Amplifier, 2 Watt	12	41	5	31	+15V @ 500 mA	Chip	3A001.b.2.c	HMC998
0.1 - 22.0	Power Amplifier, 2 Watt	11	41	-	31	+15V @ 500 mA	LP5	3A001.b.2.c	HMC998LP5E
0.4 - 2.2	Power Amplifier, 1 Watt	21	49	6.5	30	+5V @ 510 mA	ST89	EAR99	HMC452ST89E
0.4 - 2.2	Power Amplifier, 1.6 Watt	20.5	49	6.5	32	+5V @ 725 mA	ST89	EAR99	HMC453ST89E
0.4 - 2.7	Power Amplifier, 2 Watt	16	48	8.5	33	+5V @ 700 mA	LP4	EAR99	HMC921LP4E
0.45 - 2.2	Power Amplifier, 1 Watt	22.5	48	7	30	+5V @ 485 mA	QS16G	EAR99	HMC452QS16GE
0.45 - 2.2	Power Amplifier, 1.6 Watt	21.5	51	6.5	33	+5V @ 725 mA	QS16G	EAR99	HMC453QS16GE
DC - 32	Power Amplifier, 1/2 Watt	14	36	4	28	+10V @ 250 mA	Chip	EAR99	HMC994
1.7 - 2.2	Power Amplifier, 1 Watt	27	46	5	30.5	+5V @ 500 mA	QS16G	EAR99	HMC457QS16GE
2.3 - 2.8	Power Amplifier, 1 Watt	31	45	5	32.5	+5V @ 430 mA	LP4	EAR99	HMC755LP4E
3 - 4	Power Amplifier, 1/2 Watt	21	40	5	27	+5V @ 250 mA	MS8G	EAR99	HMC327MS8GE

[1] Amplifiers that benefit from Hittite Active Bias Controllers

SMT & Chip (Die) Products

AMPLIFIERS

Frequency (GHz)	Function	Gain (dB)	OIP3 (dBm)	NF (dB)	P1dB (dBm)	Bias Supply	Package	ECCN Code	Part Number
3.3 - 3.8	Power Amplifier, 1 Watt	31	45.5	5.8	30.5	+5V @ 615 mA	LP4	EAR99	HMC409LP4E
5.1 - 5.9	Power Amplifier, 1 Watt	20	43	6	30	+5V @ 750 mA	LP3	EAR99	HMC408LP3E
6 - 9.5	Power Amplifier, 1 Watt	21	40	-	30.5	+7V @ 820 mA	LP5	EAR99	HMC590LP5E
6 - 9.5	Power Amplifier, 2 Watt	18	41	-	33	+7V @ 1340 mA	LP5	3A001.b.2.b	HMC591LP5E
6 - 10	Power Amplifier, 1 Watt	25	41	-	31.5	+7V @ 820 mA	Chip	3A001.b.2.b	HMC590
6 - 10	Power Amplifier, 2 Watt	23	43	-	33.5	+7V @ 1340 mA	Chip	3A001.b.2.b	HMC591
7 - 9	Power Amplifier, 2 Watt	26	40	6.5	33.5	+7V @ 1.3A	Chip	3A001.b.2.b	HMC486
7 - 9	Power Amplifier, 2 Watt	22	40	7	32	+7V @ 1.3A	LP5	3A001.b.2.b	HMC486LP5E
9 - 12	Power Amplifier, 2 Watt	20	36	8	32	+7V @ 1.3A	LP5	3A001.b.2.b	HMC487LP5E
9 - 13.3	Power Amplifier, 2 Watt	34	42	5.5	33	+6V @ 1400 mA	Chip	3A001.b.2.b	HMC952
9 - 14	Power Amplifier, 2 Watt	33	43	-	34	+6V @ 1400 mA	LP5G	3A001.b.2.b	HMC952LP5GE
9 - 14	Power Amplifier w/ Power Detector, 5 Watt	34	43	-	36.5	+7V @ 2400 mA	Chip	3A001.b.2.b	HMC1053
10 - 13	Power Amplifier, 1 Watt	19	38	-	31	+7V @ 750 mA	Chip	3A001.b.2.b	HMC592
12 - 16	Power Amplifier, 1 Watt	13	34	9	31	+7V @ 1.3A	LP5	EAR99	HMC489LP5E
12.5 - 15.5	Power Amplifier, 2 Watt	30	42	-	34.5	+7V @ 1200 mA	Chip	3A001.b.2.b	HMC949
12.5 - 15.5	Power Amplifier, 4 Watt	28	44	-	36	+7V @ 1200 mA	Chip	3A001.b.2.b	HMC950
12.5 - 15.5	Power Amplifier, 2 Watt	27	40	-	32	+6V @ 1200 mA	LP5	3A001.b.2.b	HMC965LP5E
12 - 16	PA with Power Detector, 3 Watt	27	41	-	34.5	+7V @ 1200 mA	LP5G	3A001.b.2.b	HMC995LP5GE
NEW! 15 - 20	Power Amplifier, 2 Watt	26	43.5	-	33.5	+6V @ 1100 mA	LS6	3A001.b.2.c	HMC6981LS6
15 - 27	Power Amplifier, 1 Watt	17	37	-	29	+5V @ 1.44A	Chip	EAR99	HMC-APH462
16 - 24	Power Amplifier, 1 Watt	23	41	-	31	+7V @ 790 mA	Chip	3A001.b.2.c	HMC756
16 - 24	Power Amplifier, 1/2 Watt	22	37	-	29	+7V @ 395 mA	Chip	EAR99	HMC757
16 - 24	Power Amplifier, 1/2 Watt	20.5	34.5	-	26.5	+5V @ 400 mA	LP4	EAR99	HMC757LP4E
18 - 20	Power Amplifier, 1 Watt	17.5	38.5	-	30	+5V @ 900 mA	Chip	3A001.b.2.c	HMC-APH478
21 - 24	Power Amplifier, 1 Watt	17	39	-	30.5	+5V @ 950 mA	Chip	3A001.b.2.c	HMC-APH518
22 - 26.5	Power Amplifier, 1/2 Watt	20	33	7	26.5	+5V @ 400 mA	LP4	EAR99	HMC863LP4E
22.5 - 26.5	Power Amplifier, 1 Watt	17	40	-	30	+5V @ 950 mA	Chip	3A001.b.2.c	HMC-APH608
24 - 29.5	Power Amplifier, 1/2 Watt	22	-	-	26.5	+6V @ 360 mA	Chip	EAR99	HMC863
24 - 29.5	Power Amplifier, 1 Watt	27	40	-	29	+6V @ 750 mA	Chip	3A001.b.2.c	HMC864
24 - 31.5	Power Amplifier, 1.5 Watt	22	43	-	34	+5.5V @ 1200 mA	LP5	3A001.b.2.c	HMC943LP5E
27 - 31.5	Power Amplifier, 1/2 Watt	14	37	-	28	+5V @ 900 mA	Chip	3A001.b.2.c	HMC-APH460
27 - 34	Power Amplifier, 1 Watt	17.5	37	-	29	+5V @ 800 mA	Chip	3A001.b.2.d	HMC693
27.3 - 33.5	Power Amplifier, 2 Watt	23	43	-	33	+6V @ 1200 mA	Chip	3A001.b.2.d	HMC906
27.5 - 33.5	Power Amplifier, 1 Watt	24	40	-	29	+6V @ 600 mA	Chip	3A001.b.2.d	HMC1024
29 - 37	Power Amplifier, 2 Watt	22	42	6	32	+6V @ 1200 mA	Chip	3A001.b.2.d	HMC1029
37 - 40	Power Amplifier, 1 Watt	15	37	-	28	+5V @ 1.08A	Chip	3A001.b.2.d	HMC-APH473
37 - 40	Power Amplifier, 1 Watt	21	38	-	30.5	+6V @ 900 mA	Chip	3A001.b.2.d	HMC968
NEW! 37 - 40	Power Amplifier, 1 Watt	22	38	-	30	+6V @ 960 mA	LS6	3A001.b.2.d	HMC7229LS6
40 - 43.5	Power Amplifier, 1 Watt	22	38	-	29	+6V @ 900 mA	Chip	EAR99	HMC969

Wideband (Distributed) Amplifiers

DC - 20	Wideband LNA	14	28	2.5	16	+8V @ 60 mA	Chip	EAR99	HMC460 [1]
DC - 20	Wideband LNA	14	29.5	2.5	17	+8V @ 75 mA	LC5	EAR99	HMC460LC5 [1]
0.3 - 20.0	Wideband LNA	16	27	1.7	15	+7V @ 70mA	Chip	EAR99	HMC1049
0.3 - 20.0	Wideband LNA	15	29	1.8	14.5	+7V @ 70mA	Chip	EAR99	HMC1049LP5E
2 - 20	Wideband LNA	15	26.5	2.5	15	+5V @ 63 mA	Chip	EAR99	HMC462
2 - 20	Wideband LNA	13	25	2.5	14	+5V @ 66 mA	LP5	EAR99	HMC462LP5E
2 - 20	Wideband LNA with AGC	14	28	2.5	19	+5V @ 60 mA	Chip	EAR99	HMC463 [1]
2 - 20	Wideband LNA with AGC	13	26	3	18	+5V @ 60 mA	LP5	EAR99	HMC463LP5E [1]
2 - 20	Wideband LNA with AGC	14	28	2.5	18	+5V @ 60 mA	LH250	EAR99	HMC463LH250
2 - 20	Wideband LNA	10	-	3.5	10	+2V @ 55 mA	Chip	EAR99	HMC-ALH102
2 - 22	Wideband LNA	16	-	1.7	14	+4V @ 45 mA	Chip	EAR99	HMC-ALH482
DC - 20	Wideband Driver	17	30	2.5	22	+8V @ 160 mA	Chip	EAR99	HMC465 [1]
DC - 20	Wideband Driver	15	28	3	23	+8V @ 160 mA	LP5	EAR99	HMC465LP5E [1]
DC - 35	Wideband Driver	15	-	-	21	+5V @ 200 mA	Chip	3A001.b.2.d	HMC-AUH249
DC - 43	Wideband Driver	14	-	5.4	16.5	+5V @ 180 mA	Chip	3A001.b.2.d	HMC-AUH232
0.5 - 65	Wideband Driver	10	-	-	-	+8V @ 60 mA	Chip	3A001.b.2.f	HMC-AUH312
2 - 35	Wideband Driver	12.5	27	3	18	+8V @ 80 mA	Chip	3A001.b.2.d	HMC562 [1]
5 - 17	Wideband Driver	31	30	8	23	+5V @ 180 mA	Chip	EAR99	HMC633 [1]
5 - 20	Wideband Driver	22	31	7.5	23	+5V @ 180 mA	Chip	EAR99	HMC634 [1]
5 - 20	Wideband Driver	21	29	7.5	22	+5V @ 180 mA	LC4	EAR99	HMC634LC4 [1]
5.5 - 17	Wideband Driver	30	30	8	23	+5V @ 180 mA	LC4	EAR99	HMC633LC4 [1]

[1] Amplifiers that benefit from Hittite Active Bias Controllers

AMPLIFIERS

Frequency (GHz)	Function	Gain (dB)	OIP3 (dBm)	NF (dB)	P1dB (dBm)	Bias Supply	Package	ECCN Code	Part Number
18 - 40	Wideband Driver	19.5	29	8	23	+5V @ 280 mA	Chip	3A001.b.2.d	HMC635
18 - 40	Wideband Driver	18.5	27	7	22	+5V @ 280 mA	LC4	3A001.b.2.d	HMC635LC4
DC - 6	Wideband Power Amplifier	14	45	5	29	+12V @ 400 mA	Chip	EAR99	HMC637
DC - 6	Wideband Power Amplifier	13	40	5	29	+12V @ 400 mA	LP5	EAR99	HMC637LP5E
DC - 10	Wideband Power Amplifier	12	41	6	28.5	+12V @ 300 mA	Chip	EAR99	HMC619
DC - 10	Wideband Power Amplifier	12	41	6	28	+12V @ 300 mA	LP5	EAR99	HMC619LP5E
DC - 15	Wideband Power Amplifier	19	35	2	26.5	+8V @ 300 mA	Chip	EAR99	HMC659
DC - 15	Wideband Power Amplifier	19	35	2.5	27.5	+8V @ 300 mA	LC5	EAR99	HMC659LC5
DC - 18	Wideband Power Amplifier	17	32	3	25	+8V @ 290 mA	Chip	EAR99	HMC459
DC - 20	Wideband Power Amplifier	14	36	4	28	+10V @ 400 mA	Chip	3A001.b.2.c	HMC559
DC - 22	Wideband Power Amplifier	14	40	2.5	28	+11V @ 400 mA	Chip	3A001.b.2.c	HMC797
DC - 22	Wideband Power Amplifier	13.5	39	4	28	+10V @ 400 mA	LP5	EAR99	HMC797LP5E
DC - 28	Wideband Power Amplifier	13	38	4	27	+10V @ 250 mA	LP5	EAR99	HMC994LP5E
DC - 40	Wideband Power Amplifier	13	33.5	5	22	+10V @ 175 mA	Chip	3A001.b.2.d	HMC930 [1]
DC - 48	Wideband Power Amplifier	12	32	-	22	+10V @ 150 mA	Chip	3A001.b.2.f	HMC1022
0.2 - 22	Wideband Power Amplifier	13	38	3	27	+11V @ 365 mA	Chip	EAR99	HMC907
0.2 - 22	Wideband Power Amplifier	12	36	3.5	26	+10V @ 350 mA	LP5	EAR99	HMC907LP5E
2 - 20	Wideband Power Amplifier	16	30	4	26	+8V @ 290 mA	Chip	EAR99	HMC464
2 - 20	Wideband Power Amplifier	14	30	4	26	+8V @ 290 mA	LP5	EAR99	HMC464LP5E

[1] Amplifiers that benefit from Hittite Active Bias Controllers

AMPLIFIERS - Low Phase Noise

Frequency (GHz)	Function	Gain / NF (dB)	OIP3 (dBm)	10 kHz SSB Phase Noise (dBc/Hz)	P1dB / Psat (dBm)	Bias Supply	Package	ECCN Code	Part Number
2 - 18	Wideband, Low Phase Noise	14 / 4.5	27	-160	15 / 18	+5V @ 64 mA	Chip	EAR99	HMC606
2 - 18	Wideband, Low Phase Noise	13.5 / 5	27	-160	15 / 17	+5V @ 64 mA	LC5	EAR99	HMC606LC5

ATTENUATORS

Frequency (GHz)	Function	Insertion Loss (dB)	Attenuation Range (dB)	IIP3 (dBm)	Control Input (Vdc)	Package	ECCN Code	Part Number
0.45 - 2.2	Analog VVA	1.9	0 to 48	20	0 to +3V	MS8	EAR99	HMC473MS8E
0.5 - 6.0	Analog VVA	2.5	0 to 26	35	0 to +5V	LP3	EAR99	HMC973LP3E
DC - 8	Analog VVA	1.5	0 to 32	10	0 to -3V	MS8G	EAR99	HMC346MS8GE
DC - 8	Analog VVA	2	0 to 30	10	0 to -3V	C8	EAR99	HMC346C8
DC - 8	Analog VVA	2	0 to 30	10	0 to -3V	G8 Hermetic	EAR99	HMC346G8
DC - 14	Analog VVA	2	0 to 30	10	0 to -3V	LP3	EAR99	HMC346LP3E
DC - 18	Analog VVA	1.5	0 to 30	10	0 to -3V	LC3B	EAR99	HMC346LC3B
DC - 20	Analog VVA	2.2	0 to 25	10	0 to -3V	Chip	EAR99	HMC346
5 - 26.5	Analog VVA	3.5	0 to 28	32	0 to -3V	LP3C	EAR99	HMC712LP3CE
5 - 30	Analog VVA	2.5	0 to 30	32	0 to -3V	Chip	EAR99	HMC712
5 - 30	Analog VVA	2	0 to 28	28	0 to -3V	LC4	EAR99	HMC812LC4
10 - 40	Analog VVA	3	0 to 35	33	0 to +3V	LP4K	EAR99	HMC985LP4KE
17 - 27	Analog VVA	1.5	0 to 22	17	-4 to +4V	Chip	5A991.h	HMC-VVD102
20 - 50	Analog VVA	3	0 to 35	33	0 to +3V	Chip	EAR99	HMC985
36 - 50	Analog VVA	1.5	0 to 22	17	0 to +4V	Chip	5A991.h	HMC-VVD106
70 - 86	Analog VVA	2	0 to 14	-	-5 to +5V	Chip	5A991.h	HMC-VVD104

Attenuators - Digital

DC - 5	1-Bit Digital	1	10	50	TTL/CMOS	LP3	EAR99	HMC541LP3E
DC - 10	1-Bit Digital	2	10	54	0 / +3 to +5V	LP3	EAR99	HMC800LP3E
DC - 10	1-Bit Digital	1.5	15	53	0 / +3 to +5V	LP3	EAR99	HMC801LP3E
DC - 10	1-Bit Digital	2.5	20	53	0 / +3 to +5V	LP3	EAR99	HMC802LP3E
0.7 - 4.0	2-Bit Digital	0.5	2 to 6	52	0 / +3V	SOT26	EAR99	HMC290E
0.7 - 4.0	2-Bit Digital	0.9	4 to 12	54	0 / +3V	SOT26	EAR99	HMC291E
DC - 6	2-Bit Digital	0.5	2 to 6	50	TTL/CMOS	LP3	EAR99	HMC467LP3E
0.75 - 2.0	3-Bit Digital	1.8	4 to 28	45	0 / +3V	MS8	EAR99	HMC230MS8E
0.7 - 3.7	3-Bit Digital	1.3	2 to 14	51	0 / +3V	MS8	EAR99	HMC288MS8E
DC - 6	3-Bit Digital	0.7	1 to 7	50	TTL/CMOS	LP3	EAR99	HMC468LP3E
DC - 5.5	4-Bit Digital	0.8	1 to 15	50	TTL/CMOS	LP3	EAR99	HMC540LP3E
DC - 6	4-Bit Digital, Serial & Parallel Control	2.5	3 to 45	50	0 / +5V	LP4	EAR99	HMC629LP4E
0.1 - 30	5-Bit Digital	2.5	0.5 to 15.5	45	0 / +3 to +5V	Chip	EAR99	HMC941
0.1 - 30	5-Bit Digital, Serial Control	5	1 to 31	43	0 / +3 to +5V	LP4	EAR99	HMC1018LP4E
0.1 - 30	5-Bit Digital, Serial Control	4	0.5 to 15.5	45	0 / +3 to +5V	LP4	EAR99	HMC1019LP4E

SMT & Chip (Die) Products

ATTENUATORS

Frequency (GHz)	Function	Insertion Loss (dB)	Attenuation Range (dB)	IIP3 (dBm)	Control Input (Vdc)	Package	ECCN Code	Part Number
0.1 - 33	5-Bit Digital	5	1 to 31	43	0 / +3 to +5V	LP4	EAR99	HMC939LP4E
0.1 - 33	5-Bit Digital	4	0.5 to 15.5	45	0 / +3 to +5V	LP4	EAR99	HMC941LP4E
0.1 - 40	5-Bit Digital	3.5	1 to 31	43	0 / +3 to +5V	Chip	EAR99	HMC939
0.7 - 2.7	5-Bit Digital	2.3	1 to 31	54	0 / +3V	QS16	EAR99	HMC274QS16E
0.7 - 3.7	5-Bit Digital, Serial Control	2.1	1 to 31	48	Serial/CMOS	LP4	EAR99	HMC271ALP4E
0.7 - 3.8	5-Bit Digital	2.1	1 to 31	48	0 / +3V	MS10G	EAR99	HMC273MS10GE
0.7 - 3.8	5-Bit Digital, Serial Control	1.5	0.5 to 15.5	52	Serial/CMOS	LP4	EAR99	HMC305ALP4E
0.7 - 3.8	5-Bit Digital	1.5	0.5 to 15.5	52	0 / +3V	MS10	EAR99	HMC306MS10E
0.7 - 3.8	5-Bit Digital	1.3	0.5 to 15.5	48	0 / +3V	MS10	EAR99	HMC603MS10E
0.7 - 3.8	5-Bit Digital	1.3	0.5 to 15.5	48	0 / +3V	QS16	EAR99	HMC603QS16E
DC - 3	5-Bit Digital	2.0	1 to 31	44	0 / -5V	G16 Hermetic	EAR99	HMC335G16
DC - 3	5-Bit Digital	1.3	1 to 31	45	TTL/CMOS	LP3	EAR99	HMC470LP3E
DC - 4	5-Bit Digital	1.9	1 to 31	44	0 / -5V	QS16G	EAR99	HMC307QS16GE
DC - 4	5-Bit Digital	0.7	0.25 to 7.75	50	TTL/CMOS	LP3	EAR99	HMC539LP3E
DC - 3.8	6-Bit Digital	1.5	0.5 to 31.5	45	TTL/CMOS	LP4	EAR99	HMC472LP4E
DC - 3	6-Bit Digital	3.0	0.5 to 31.5	32	0 / -5V	G16 Hermetic	EAR99	HMC424G16
DC - 4	6-Bit Digital, Serial Control	1.2	0.5 to 31.5	45	Serial/CMOS	LP4	EAR99	HMC542ALP4E
DC - 6	6-Bit Digital, Serial & Parallel Control	1.8	0.5 to 31.5	55	0 / +5V	LP4	EAR99	HMC624LP4E
DC - 6	6-Bit Digital, Serial & Parallel Control	1.8	0.25 to 15.75	55	TTL/CMOS	LP4	EAR99	HMC792LP4E
DC - 13	6-Bit Digital	4.0	0.5 to 31.5	32	0 / -5V	Chip	EAR99	HMC424
DC - 13	6-Bit Digital	3.2	0.5 to 31.5	32	0 / -5V	LH5 Hermetic	EAR99	HMC424LH5
DC - 13	6-Bit Digital	4.0	0.5 to 31.5	32	0 / -5V	LP3	EAR99	HMC424LP3E
0.06 - 0.5	6-Bit Digital, Serial & Parallel Control	1.2	0.5 to 31.5	55	0 / +3 to +5V	LP4	EAR99	HMC624LFLP4E
2.4 - 8.0	6-Bit Digital	3.5	0.5 to 31.5	40	0 / +5V	Chip	EAR99	HMC425
2.2 - 8.0	6-Bit Digital	3.2	0.5 to 31.5	40	0 / +5V	LP3	EAR99	HMC425LP3E
0.01 - 0.3	7-Bit Digital	3.3	0.25 to 31.75	40	TTL/CMOS	LP3	EAR99	HMC759LP3E

AUTOMATIC GAIN CONTROL

Frequency (MHz)	Function	Gain Control Range (dB)	NF (dB)	OIP3 (dBm)	P1dB (dBm)	Bias Supply	Package	ECCN Code	Part Number
50 - 800	IF Automatic Gain Controller	-10 to +38	6	40	19	+5V @ 215 mA	LP5	EAR99	HMC992LP5E
700 - 3000	RF Automatic Gain Controller	-11 to +32	7.6	46	25	+5V @ 260 mA	LP5	EAR99	HMC993LP5E

DC POWER CONDITIONING - Linear Voltage Regulators

Input Voltage (V)	Function	Output Voltage (V)	Max. Output Current (mA)	Power Supply Rejection Ratio (PSRR) (dB)		Output Noise Spectral Density (nV/√Hz)		Regulated Outputs	Package	ECCN Code	Part Number
				1 kHz	1 MHz	1 kHz	10 kHz				
3.35 - 5.6	Quad High PSRR	2.5 - 5.2	240	80	60	7	3	4	LP3	EAR99	HMC860LP3E
3.35 - 5.6	Low Noise, High PSRR	1.8 - 5.2	500	80	60	7	3	4	LP3	EAR99	HMC1060LP3E
4.8 to 5.6	Low Noise, High PSRR	1.8 to 5.1	400	60	30	6	3	1	LP3	EAR99	HMC976LP3E

FILTERS - Tunable

Band Pass

Frequency Range (GHz)	Function	Return Loss (dB)	3 dB Bandwidth (%)	Low Side Rejection Frequency (Rej. >20 dB)	High Side Rejection Frequency (Rej. >20 dB)	Tuning Response (ns)	Package	ECCN Code	Part Number
1 - 2	Band Pass	10	11	0.8 x Fcenter	1.2 x Fcenter	< 200	LP5	EAR99	HMC890LP5E
2 - 3.9	Band Pass	10	9	0.9 x Fcenter	1.15 x Fcenter	< 200	LP5	EAR99	HMC891LP5E
4 - 7.7	Band Pass	15	9	0.9 x Fcenter	1.13 x Fcenter	< 200	LP5	EAR99	HMC892LP5E
4.8 - 9.5	Band Pass	7	6.5	0.9 x Fcenter	1.1 x Fcenter	< 200	LP5	EAR99	HMC893LP5E
5.9 - 11.2	Band Pass	7.5	6	0.92 x Fcenter	1.08 x Fcenter	< 200	LP5	EAR99	HMC894LP5E
6.8 - 12.6	Band Pass	12	10	0.88 x Fcenter	1.1 x Fcenter	< 200	LP4	EAR99	HMC895LP4E
9 - 19	Band Pass	9.5	18	0.81 x Fcenter	1.17 x Fcenter	< 200	Chip	EAR99	HMC897
9 - 19	Band Pass	9.5	18	0.81 x Fcenter	1.17 x Fcenter	< 200	LP4	EAR99	HMC897LP4E
10 - 18	Band Pass	11	9	0.89 x Fcenter	1.1 x Fcenter	< 200	LP4	EAR99	HMC896LP4E
11.5 - 21.5	Band Pass	9	17	0.81 x Fcenter	1.16 x Fcenter	< 200	LP4	EAR99	HMC898LP4E
18.5 - 37.0	Band Pass	10	18	0.81 x Fcenter	1.20 x Fcenter	< 200	LP4	EAR99	HMC899LP4E
19 - 38	Band Pass	10	18	0.81 x Fcenter	1.20 x Fcenter	< 100	Chip	EAR99	HMC899

Low Pass

Frequency Range (GHz)	Function	Return Loss (dB)	Cutoff Frequency Range (GHz)	Stopband Frequency (Rej. >20 dB)	Tuning Response (ns)	Package	ECCN Code	Part Number
DC - 4.0	Low Pass	10	2.2 - 4.0	1.25 x Fcutoff	150	LP5	EAR99	HMC881LP5E
DC - 7.6	Low Pass	10	4.5 - 7.6	1.23 x Fcutoff	150	LP5	EAR99	HMC882LP5E

Band Reject

Frequency Range (GHz)	Function	Rejection Band Tuning Freq. (GHz)	Pass Band Insertion Loss (dB)	Stop Band Rejection (dB)	20 dB Bandwidth (%)	Tuning Response (ns)	Package	ECCN Code	Part Number
0.1 - 25	Band Reject	3.6 - 12.2	3	25	8	200	LP5	EAR99	HMC1000LP5E

Programmable Harmonic

Frequency Range (GHz)	Function	Return Loss (dB)	3 dB Bandwidth (GHz)	Stopband Frequency (Rej. >10 dB)	Tuning Response (ns)	Package	ECCN Code	Part Number
0.25 - 3.025	Programmable Harmonic Low Pass Filter	10	1 - 3	1.2 Fcutoff	10	LP3	EAR99	HMC1044LP3E

IF / BASEBAND PROCESSING - Dual Baseband Low Pass Filter & Dual Baseband Digital VGA

Dual Baseband Low Pass Filter

3 dB Bandwidth Setting (MHz)	Function	3 dB Bandwidth Accuracy (%)	Gain (dB)	NF (dB)	OIP3 (dBm)	Package	ECCN Code	Part Number
3.5 - 50	Dual Low Pass with ADC Driver	± 2.5	0 / 10	12	30	LP5	EAR99	HMC900LP5E
5 - 72	Dual Low Pass with ADC Driver	± 2.5	0 / 10	10	30	LP5	EAR99	HMC1023LP5E

Please Note: 400 Ohm Reference Impedance Are Shown

Dual Baseband Digital VGA

Frequency (MHz)	Function	NF (dB)	Variable Gain (dB)	OIP3 (dBm)	OIP2 (dBm)	Sidband Supp. (dB)	Magnitude (dB) / Phase (deg) Balance	Bias Supply	Package	ECCN Code	Part Number
DC - 100	Digital, Serial & Parallel Control	6	0 to 40	+30	+65	55	±0.1 / ±1	+5V @ 70 mA	LP4	EAR99	HMC960LP4E

Please Note: 100 Ohm Reference Impedance Are Shown

I/Q MIXERS / IRMs

RF Frequency (GHz)	Function	IF Frequency (GHz)	Conversion Gain (dB)	Image Rejection (dB)	IIP3 (dBm)	Package	ECCN Code	Part Number
3 - 7	I/Q Mixer / IRM	DC - 3.5	-7.5	33	23	Chip	EAR99	HMC620
3 - 7	I/Q Mixer / IRM	DC - 3.5	-7.5	32	22	LC4	EAR99	HMC620LC4
4 - 8.5	I/Q Mixer / IRM	DC - 3.5	-7.5	40	23	Chip	EAR99	HMC525
4 - 8.5	I/Q Mixer / IRM	DC - 3.5	-7.5	40	23	LC4	EAR99	HMC525LC4
5.9 - 12.0	I/Q Mixer / IRM	DC - 1.5	-8	30	18	Chip	EAR99	HMC256
6 - 10	I/Q Mixer / IRM	DC - 3.5	-7	40	22	Chip	EAR99	HMC520
6 - 10	I/Q Mixer / IRM	DC - 3.5	-7	40	23	LC4	EAR99	HMC520LC4
6 - 10	I/Q Mixer / IRM	DC - 3.5	-7.5	40	28	Chip	EAR99	HMC526
6 - 10	I/Q Mixer / IRM	DC - 3.5	-7.5	40	28	LC4	EAR99	HMC526LC4
8 - 12	I/Q Mixer / IRM	DC - 4	-8	25	18	LC4B	EAR99	HMC1056LP4BE
8.5 - 13.5	I/Q Mixer / IRM	DC - 3.5	-7.5	40	24	Chip	EAR99	HMC521
8.5 - 13.5	I/Q Mixer / IRM	DC - 3.5	-7.5	38	24	LC4	EAR99	HMC521LC4
8.5 - 13.5	I/Q Mixer / IRM	DC - 2	-7.5	35	28	Chip	EAR99	HMC527
8.5 - 13.5	I/Q Mixer / IRM	DC - 2	-7.5	34	28	LC4	EAR99	HMC527LC4
10 - 16	I/Q Mixer / IRM	DC - 3.5	-8	25	25	LC5	EAR99	HMC775LC5
11 - 16	I/Q Mixer / IRM	DC - 3.5	-7.5	35	24	Chip	EAR99	HMC522
11 - 16	I/Q Mixer / IRM	DC - 3.5	-7.5	35	24	LC4	EAR99	HMC522LC4
11 - 16	I/Q Mixer / IRM	DC - 3.5	-8	35	27	Chip	EAR99	HMC528
11 - 16	I/Q Mixer / IRM	DC - 3.5	-8	35	26	LC4	EAR99	HMC528LC4
15 - 23	I/Q Mixer / IRM	DC - 3.5	-8	25	25	LC4	EAR99	HMC523LC4
15 - 23.6	I/Q Mixer / IRM	DC - 3.5	-8	27	25	Chip	EAR99	HMC523
15 - 33.5	I/Q Mixer / IRM	DC - 3.5	-10	40	22	LC4	EAR99	HMC1042LC4
17 - 27	I/Q Mixer / IRM	DC - 3.5	-9	36	20	LC4	EAR99	HMC1041LC4
19 - 33	I/Q Mixer / IRM	DC - 5	-8	25	17	Chip	5A991.h	HMC-MDB172
22 - 32	I/Q Mixer / IRM	DC - 3.5	-10	23	20	Chip	EAR99	HMC524
22 - 32	I/Q Mixer / IRM	DC - 4.5	-10	20	20	LC3B	EAR99	HMC524LC3B
24 - 28	I/Q Mixer / IRM	DC - 3	-9.5	21	17	LP3	EAR99	HMC1063LP3E
31 - 38	I/Q Mixer / IRM	DC - 3.5	-10.5	17	21	Chip	EAR99	HMC555
35 - 45	I/Q Mixer / IRM	DC - 5	-8	25	17	Chip	5A991.h	HMC-MDB171
36 - 41	I/Q Mixer / IRM	DC - 3.5	-11	18	23	Chip	EAR99	HMC556
55 - 64	I/Q Mixer / IRM	DC - 3	-9	30	16	Chip	5A991.h	HMC-MDB207

SMT & Chip (Die) Products

I/Q MIXERS / IRMs

RF Frequency (GHz)	Function	IF Frequency (GHz)	Conversion Gain (dB)	Image Rejection (dB)	IIP3 (dBm)	Package	ECCN Code	Part Number
26 - 33 RF	Sub-Harmonic, I/Q Mixer / IRM	DC - 3	-11	22	16	Chip	EAR99	HMC404
54 - 64 RF	Sub-Harmonic, I/Q Mixer / IRM	DC - 3	-12.5	30	7	Chip	5A991.h	HMC-MDB218
71 - 86	Sub-Harmonic, I/Q Mixer / IRM	DC - 12	-12	-	13	Chip	EAR99	HMC1057

I/Q DOWNCONVERTER / RECEIVERS

RF Frequency (GHz)	Function	IF Frequency (GHz)	Conversion Gain (dB)	Noise Figure (dB)	Image Rejection (dB)	IIP3 (dBm)	Package	ECCN Code	Part Number
5.6 - 8.6	I/Q Downconverter / Receiver	DC - 3	12	2.2	20	2	LP4	EAR99	HMC951LP4E
7 - 9	I/Q Downconverter / Receiver	DC - 3.5	10	2.5	35	1.5	LC5	EAR99	HMC567LC5
9 - 12	I/Q Downconverter / Receiver	DC - 3.5	11	2.2	25	2	LC5	EAR99	HMC908LC5
12 - 16	I/Q Downconverter / Receiver	DC - 3.5	14	2.8	32	-1	LC5	EAR99	HMC869LC5
17 - 20	I/Q Downconverter / Receiver	DC - 3.5	14	2.5	40	0	LP4	EAR99	HMC966LP4E
17 - 21	I/Q Downconverter / Receiver	DC - 3.5	10	3	17	3	Chip	EAR99	HMC570
17 - 21	I/Q Downconverter / Receiver	DC - 3.5	10	3	18	2	LC5	EAR99	HMC570LC5
17 - 24	I/Q Downconverter / Receiver	DC - 3.3	11	2.2	21	2	LC5	EAR99	HMC904LC5
17 - 24	I/Q Downconverter / Receiver	DC - 3.5	15	2.5	25	1	LP4	EAR99	HMC967LP4E
20 - 28	I/Q Downconverter / Receiver	DC - 3.5	14	2.5	21	1	LP4	EAR99	HMC977LP4E
21 - 25	I/Q Downconverter / Receiver	DC - 3.5	11	3	24	5	Chip	EAR99	HMC571
21 - 25	I/Q Downconverter / Receiver	DC - 3.5	10	2	20	5	LC5	EAR99	HMC571LC5
24 - 28	I/Q Downconverter / Receiver	DC - 3.5	8	3.5	20	5	Chip	EAR99	HMC572
24 - 28	I/Q Downconverter / Receiver	DC - 3.5	8	3.5	18	5	LC5	EAR99	HMC572LC5
NEW! 27 - 34	I/Q Downconverter / Receiver	DC - 4	12	3.5	17	2	LP4	EAR99	HMC1065LP4E
37 - 44	I/Q Downconverter / Receiver	DC - 4	13	3.5	25	2	LC5A	EAR99	HMC6147ALC5A

I/Q UPCONVERTER / TRANSMITTERS

RF Frequency (GHz)	Function	IF Frequency (GHz)	Conversion Gain (dB)	Sideband Rejection (dBc)	OIP3 (dBm)	Package	ECCN Code	Part Number
5.5 - 8.6	I/Q Upconverter / Transmitter w/ VGA	DC - 3	16.5	-30	29	LC5	EAR99	HMC925LC5
10 - 16	I/Q Upconverter / Transmitter w/ VGA	DC - 3	17	-30	14	LC5	EAR99	HMC924LC5
11 - 17	I/Q Upconverter / Transmitter	DC - 2	13	-20	26	LC5	EAR99	HMC709LC5
16 - 21	I/Q Upconverter / Transmitter	DC - 3.5	12	-20	30	LC5	EAR99	HMC710LC5
17.7 - 23.6	I/Q Upconverter / Transmitter	DC - 3.5	15	-35	35	LC5	EAR99	HMC819LC5
21 - 27	I/Q Upconverter / Transmitter	DC - 3.75	12	-20	27	LC5	EAR99	HMC815LC5
37 - 40	I/Q Upconverter / Transmitter w/ VGA	DC - 4	10	17	27	LC5A	EAR99	HMC6787ALC5A
40 - 44	I/Q Upconverter / Transmitter w/ VGA	DC - 4	12	25	27	LC5A	EAR99	HMC6146BLC5A

MIXERS

RF Frequency (GHz)	Function	IF Frequency (GHz)	Conversion Gain (dB)	LO / RF Isolation (dB)	IIP3 (dBm)	Package	ECCN Code	Part Number
High IP3 Mixers								
0.4 - 0.65	High IP3, 0 LO	DC - 0.25	-9	7	33	MS8G	EAR99	HMC585MS8GE
0.45 - 0.5	High IP3, SGL-END	DC - 0.15	-9.5	20	32	MS8	EAR99	HMC387MS8E
0.5 - 2.7	High IP3, DBL-BAL, +2 LO	DC - 1	-8	28	28	LP4	EAR99	HMC915LP4E
0.7 - 1.0	High IP3, SGL-END	DC - 0.25	-8.5	24	35	MS8	EAR99	HMC399MS8E
0.7 - 1.0	High IP3, DBL-BAL, 0 LO	DC - 0.45	-7	23	32	LP4	EAR99	HMC684LP4E
0.7 - 1.1	High IP3, DBL-BAL, 0 LO	0.05 - 0.25	-7.5	24	40	LP4	EAR99	HMC786LP4
0.7 - 1.2	High IP3, DBL-BAL	DC - 0.3	-9	42	25	S8	EAR99	HMC351S8E
0.7 - 1.5	High IP3, 0 LO	DC - 0.35	-9	20	33	MS8G	EAR99	HMC483MS8GE
0.7 - 1.5	High IP3, DBL-BAL, 0 LO	DC - 0.5	-7.5	24	34	LP4	EAR99	HMC686LP4E
0.8 - 1.2	High IP3, DBL-BAL, 0 LO	DC - 0.3	-8	27	27	LP4	EAR99	HMC551LP4E
1.5 - 3.5	High IP3, DBL-BAL	DC - 1	-8	38	25	MS8	EAR99	HMC316MS8E
1.6 - 3.0	High IP3, DBL-BAL, 0 LO	DC - 1	-8	30	25	LP4	EAR99	HMC552LP4E
1.7 - 2.2	High IP3, SGL-END	DC - 0.3	-8.8	30	36	MS8	EAR99	HMC400MS8E
1.7 - 2.2	High IP3, DBL-BAL, 0 LO	DC - 0.5	-8	30	35	LP4	EAR99	HMC685LP4E
1.7 - 2.2	High IP3, DBL-BAL, 0 LO	DC - 0.5	-8	31	34	LP4	EAR99	HMC687LP4E
1.7 - 2.2	High IP3, DBL-BAL, 0 LO	0.05 - 0.30	-8	30	38	LP4	EAR99	HMC785LP4E
1.7 - 2.4	High IP3, SGL-END	0.05 - 0.3	-9.2	10	34	MS8G	EAR99	HMC485MS8GE
1.7 - 3.0	High IP3, SGL-BAL	DC - 0.8	-9	30	30	MS8	EAR99	HMC304MS8E
1.7 - 4.0	High IP3, DBL-BAL, +4 LO	DC - 1.0	-8	32	25	LP4	EAR99	HMC215LP4E
1.8 - 2.2	High IP3, SGL-END	DC - 0.5	-8.5	25	31	MS8	EAR99	HMC402MS8E
2.0 - 2.7	High IP3, DBL-BAL, 0 LO	DC - 0.45	-7.5	25	31	LP4	EAR99	HMC688LP4E
2.0 - 2.7	High IP3, DBL-BAL, 0 LO	DC - 0.45	-7.5	26	31	LP4	EAR99	HMC689LP4E
2.3 - 4.0	High IP3, +4 LO	DC - 1	-10	15	35	LP4	EAR99	HMC615LP4E
2.4 - 4.0	High IP3, SGL-END	DC - 1	-10	30	34	MS8	EAR99	HMC214MS8E
3.1 - 3.9	High IP3, DBL-BAL, 0 LO	DC - 0.6	-8.5	28	30	LP4	EAR99	HMC666LP4E

MIXERS

RF Frequency (GHz)	Function	IF Frequency (GHz)	Conversion Gain (dB)	LO / RF Isolation (dB)	IIP3 (dBm)	Package	ECCN Code	Part Number
6 - 12	High IP3, DBL-BAL	DC - 4	-8	40	30	LC3	EAR99	HMC663LC3
9 - 15	High IP3, DBL-BAL	DC - 2.5	-7.5	40	24	MS8G	EAR99	HMC410AMS8GE

Downconverter RFICs

0.7 - 3.5	High IP3 Dual Downconverter	0.05 - 0.35	7	55	+25	LP4	EAR99	HMC990LP4E
0.7 - 3.5	High IP3 Downconverter	0.05-0.35	7	58	25	LP3	EAR99	HMC1090LP3E
0.7 - 1.0	Downconverter	0.05 - 0.25	12.5	25	15	QS16	EAR99	HMC420QS16E
0.7 - 1.0	High IP3, Dual Downconverter	0.06 - 0.5	7.5	16	23	LP6C	EAR99	HMC683LP6CE
0.8 - 0.96	High IP3 Dual Downconverter	0.05 - 0.3	9	4	26	LP6	EAR99	HMC581LP6E
0.8 - 1.0	High IP3 Downconverter	0.05 - 0.25	13.8	28	15	QS16G	EAR99	HMC377QS16GE
0.8 - 2.7	Hi-IP3 Wideband Downconverter	0.001 - 0.6	-1	48	26	LP4	EAR99	HMC334LP4E
0.9 - 1.6	Hi-IP3 Downconverter with RF Amplifier	0.05 - 0.5	30	45	6	LP4	EAR99	HMC621LP4E
1.4 - 2.3	High IP3 Downconverter	0.05 - 0.3	9	33	19	QS16G	EAR99	HMC421QS16E
1.7 - 2.2	High IP3 Downconverter	0.05 - 0.3	11	25	19	QS16G	EAR99	HMC380QS16GE
1.7 - 2.2	High IP3, Dual Downconverter	50 - 300	9	10	27	LP6	EAR99	HMC381LP6E
1.7 - 2.2	High IP3, Dual Downconverter	0.06 - 0.4	6	25	25	LP6C	EAR99	HMC682LP6CE
1.8 - 2.7	High IP3 Downconverter with RF Amplifier	0.05 - 0.65	33	45	11	LP4	EAR99	HMC623LP4E

0 to +7 dBm LO Double & Single Balanced Mixers

0.6 - 1.3	Low LO, DBL-BAL	DC - 0.4	-8	35	15	MS8	EAR99	HMC423MS8E
0.7 - 1.2	0 LO, DBL-BAL	0.25 - 0.45	10	36	23	LP4	EAR99	HMC665LP4E
1.2 - 2.6	Low LO, DBL-BAL	DC - 1	-8	30	15	MS8	EAR99	HMC422MS8E
1.8 - 3.9	+3 LO, DBL-BAL	0.2 - 0.55	9	33	23	LP4	EAR99	HMC622LP4E
3 - 3.8	Low LO, SGL-BAL	DC - 1	-8.5	15	10	SOT26	EAR99	HMC333E
4 - 7	0 LO, DBL-BAL	DC - 2.5	-7	32	15	MS8G	EAR99	HMC488MS8GE

+10 to +12 dBm LO Double & Single Balanced Mixers

0.7 - 2.0	+10 LO, DBL-BAL	DC - 0.3	-9	45	17	S8	EAR99	HMC207AS8E
0.7 - 2.0	+10 LO, DBL-BAL	DC - 0.5	-9	24	17	MS8	EAR99	HMC208AMS8E
1.5 - 4.5	+10 LO, DBL-BAL	DC - 1.5	-8.5	40	19	MS8	EAR99	HMC213AMS8E
1.7 - 3.0	+10 LO, SGL-BAL	DC - 0.8	-9	30	21	MS8	EAR99	HMC272AMS8E
4.5 - 8.0	+10 LO, DBL-BAL	DC - 2	-8.2	35	16	C8	EAR99	HMC168C8
5 - 12	+10 LO, DBL-BAL	DC - 4	-7.5	25	17	MS8	EAR99	HMC220AMS8E
7 - 10	+10 LO, DBL-BAL	DC - 2	-9	32	16	C8	EAR99	HMC171C8
NEW! 50 - 75	+10 LO, DBL-BAL	DC - 26	-7.5	30	16	Chip	EAR99	HMC1081

+13 to +14 dBm LO Double & Triple Balanced Mixers

0.7 - 1.2	+13 LO, SGL-BAL	DC - 0.3	-9	26	21	MS8	EAR99	HMC277MS8E
1.7 - 4.5	+13 LO, DBL-BAL	DC - 1	-8	30	20	MS8	EAR99	HMC175MS8E
1.7 - 4.5	+13 LO, Dual Channel	DC - 1.5	-8	-	23	LP5	EAR99	HMC340ALP5E
2 - 18	Double Balance Mixer	DC - 4	-10	35	19	LC3B	EAR99	HMC1048LC3B
2.5 - 4.0	+13 LO, DBL-BAL	DC - 2	-9	45	18	C8	EAR99	HMC170C8
4.5 - 9.0	+13 LO, DBL-BAL	DC - 2.5	-8.5	25	21	MS8	EAR99	HMC219AMS8E
6 - 26	+13 LO, DBL-BAL	DC - 10	-9	32	20	Chip	EAR99	HMC773
6 - 26	+13 LO, DBL-BAL	DC - 8	-9	38	22	LC3B	EAR99	HMC773LC3B
7 - 14	+13 LO, DBL-BAL	DC - 5	-7	48	22	Chip	EAR99	HMC553
7 - 14	+13 LO, DBL-BAL	DC - 5	-7	50	22	LC3B	EAR99	HMC553LC3B
7 - 34	+13 LO, DBL-BAL	DC - 8	-11	35	22	LC3B	EAR99	HMC774LC3B
7 - 43	+13 LO, DBL-BAL	DC - 10	-9	35	22	Chip	EAR99	HMC774
9 - 15	+13 LO, DBL-BAL	DC - 2.5	-7.5	40 - 50	17	MS8G	EAR99	HMC412AMS8GE
10 - 15	+13 LO, SGL-BAL	DC - 3	-9	27	16	MS8G	EAR99	HMC411MS8GE
11 - 20	+13 LO, DBL-BAL	DC - 6	-7	46	18	Chip	EAR99	HMC554
11 - 20	+13 LO, DBL-BAL	DC - 6	-7	46	18	LC3B	EAR99	HMC554LC3B
14 - 26	+13 LO, DBL-BAL	DC - 8	-7.5	39	20	Chip	EAR99	HMC260
14 - 26	+13 LO, DBL-BAL	DC - 8	-7.5	38	20	LC3B	EAR99	HMC260LC3B
16 - 30	+13 LO, DBL-BAL	DC - 8	-8	40	21	LC3B	EAR99	HMC292LC3B
17 - 31	+13 LO, DBL-BAL	DC - 6	-8	32	19	LM3C	EAR99	HMC292LM3C
18 - 32	+13 LO, DBL-BAL	DC - 8	-7.5	38	19	Chip	EAR99	HMC292
24 - 32	+13 LO, DBL-BAL	DC - 8	-10	38	19	LC3B	EAR99	HMC329LC3B
24 - 40	+13 LO, DBL-BAL	DC - 18	-8	35	21	Chip	EAR99	HMC560
24 - 40	+13 LO, DBL-BAL	DC - 17	-10	35	21	LM3	EAR99	HMC560LM3
25 - 40	+13 LO, DBL-BAL	DC - 8	-9.5	42	19	Chip	EAR99	HMC329
26 - 32	+13 LO, TPL-BAL	16 - 22	-10	45	22	Chip	EAR99	HMC1015
26 - 32	+13 LO, TPL-BAL	16 - 22	-10	45	23	LC3	EAR99	HMC1043LC3
26 - 40	+13 LO, DBL-BAL	DC - 8	-8	37	19	LM3	EAR99	HMC329LM3
54 - 64	+13 LO, DBL-BAL	DC - 5	-8	30	13	Chip	5A991.h	HMC-MDB169
70 - 90	+14 LO, DBL-BAL	DC - 18	-12	-	-	Chip	5A991.h	HMC-MDB277

SMT & Chip (Die) Products

MIXERS

RF Frequency (GHz)	Function	IF Frequency (GHz)	Conversion Gain (dB)	LO / RF Isolation (dB)	IIP3 (dBm)	Package	ECCN Code	Part Number
+15 to +20 dBm LO Single, & Double Balanced Mixers								
1.8 - 5.0	+15 LO, DBL-BAL	DC - 3	-7	42	18	Chip	EAR99	HMC128
1.8 - 5.0	+15 LO, DBL-BAL	DC - 2	-10	40	18	G8 Hermetic	EAR99	HMC128G8
2.5 - 7	+15 LO, DBL-BAL	DC - 3	-7	48	22	Chip	EAR99	HMC557
2.5 - 7	+15 LO, DBL-BAL	DC - 3	-7	48	22	LC4	EAR99	HMC557LC4
4 - 8	+15 LO, DBL-BAL	DC - 3	-7	40	17	Chip	EAR99	HMC129
4 - 8	+15 LO, DBL-BAL	DC - 3	-8	30	18	G8 Hermetic	EAR99	HMC129G8
4 - 8	+15 LO, DBL-BAL	DC - 3	-7	40	17	LC4	EAR99	HMC129LC4
5.5 - 14	+15 LO, DBL-BAL	DC - 6	-7	45	24	Chip	EAR99	HMC558
5.5 - 14	+15 LO, DBL-BAL	DC - 6	-7	45	24	LC3B	EAR99	HMC558LC3B
6 - 11	+15 LO, DBL-BAL	DC - 2	-7	40	17	Chip	EAR99	HMC130
6 - 15	+15 LO, DBL-BAL	DC - 2	-8.5	35	20	C8	EAR99	HMC141C8 / 142C8
6 - 18	+15 LO, DBL-BAL	DC - 6	-10	25	21	Chip	EAR99	HMC141 / 142
7 - 14	+15 LO, DBL-BAL	DC - 2	-10	35	20	LH5 Hermetic	EAR99	HMC141LH5
14 - 23	+15 LO, DBL-BAL	DC - 2	-10.5	38	18	Chip	EAR99	HMC203
3 - 10	+17 LO, DBL-BAL	DC - 4	-9	55	23	LC3B	EAR99	HMC787LC3B
5 - 20	+20 LO, DBL-BAL	DC - 3	-10	30	25	Chip	EAR99	HMC143 / 144
6 - 20	+20 LO, DBL-BAL	DC - 3	-10	35	23	LC4	EAR99	HMC144LC4
6 - 20	+20 LO, DBL-BAL	DC - 3	-10	35	24	LH5 Hermetic	EAR99	HMC144LH5
Sub-Harmonic Mixers								
14 - 20	Sub-Harmonic	DC - 3	-10	40	7	LM3	EAR99	HMC258LM3
14 - 21	Sub-Harmonic	DC - 3	-10	40	7	Chip	EAR99	HMC258
14.5 - 19.5	Sub-Harmonic	DC - 3.5	-10	45	5	LC3B	EAR99	HMC258LC3B
17 - 25	Sub-Harmonic	DC - 3	-9	27	10	Chip	EAR99	HMC337
17.7 - 23.6	Sub-Harmonic, Upconverter	DC - 3.5	15	40	13	LC5	EAR99	HMC711LC5
20 - 30	Sub-Harmonic	DC - 4	-9	30	10	LM3	EAR99	HMC264LM3
20 - 31	Sub-Harmonic, Downconverter	0.7 - 3.0	3	28	8	LM3	EAR99	HMC265LM3
20 - 32	Sub-Harmonic	DC - 6	-10	40	13	Chip	EAR99	HMC264
20 - 32	Sub-Harmonic, Downconverter	0.7 - 3.0	3	30	10	Chip	EAR99	HMC265
20 - 40	Sub-Harmonic	1 - 3	-12	24	13	Chip	EAR99	HMC266
21 - 31	Sub-Harmonic	DC - 6	-9	40	13	LC3B	EAR99	HMC264LC3B
24 - 34	Sub-Harmonic	DC - 3	-11	33	13	LC3B	5A991.b	HMC338LC3B
24 - 34	Sub-Harmonic	DC - 4	-10	30	22	LC4	EAR99	HMC798LC4
26 - 33	Sub-Harmonic	DC - 2.5	-9	33	11	Chip	5A991.b	HMC338
33 - 42	Sub-Harmonic	DC - 3	-10	37	10	Chip	EAR99	HMC339
NEW! 71 - 86	Sub-Harmonic	DC - 12	-11	28	6	Chip	EAR99	HMC1058

DEMODULATORS - IQ Demodulator

Input Frequency (GHz)	Function	IF Frequency (GHz)	Conversion Gain (dB)	Noise Figure (dB)	IIP3 / IIP2 (dBm)	Package	ECCN Code	Part Number
0.1 - 4.0	I/Q Demodulator	DC - 0.6	-3.5	15	+25 / +60	LP4	EAR99	HMC597LP4E

MODULATORS - Bi-Phase Modulator

Input Frequency (GHz)	Function	Loss (dB)	Amp / Phase Balance (dB/Deg)	Carrier Suppression (dBc)	Bias Control (mA)	Package	ECCN Code	Part Number
1.8 - 5.2	Bi-Phase	8	0.2 / 2.5	30	+ / - 5	Chip	EAR99	HMC135
4 - 8	Bi-Phase	8	0.1 / 4.0	30	+ / - 5	Chip	EAR99	HMC136
6 - 11	Bi-Phase	9	0.25 / 10.0	20	+ / - 5	Chip	EAR99	HMC137

MODULATORS - Direct Quadrature Modulator

Input Freq. (GHz)	Function	OIP3 (dBm) / Carrier Suppression (dBc)	Modulation Bandwidth (MHz)	Output Noise Floor (dBc/Hz)	Bias Supply	Package	ECCN Code	Part Number
0.02 - 2.7	Direct Quadrature	23 / 42	DC - 700	-162	+5V @ 160 mA	LP4	EAR99	HMC696LP4E
0.05 - 2.8	Direct Quadrature with VGA	25 / 50	DC - 440	-159	+5V @ 120 mA	LP5	3A001.a.11.b	HMC795LP5E
0.1 - 4.0	Direct Quadrature	23 / 42	DC - 700	-159	+5V @ 170 mA	LP4	EAR99	HMC497LP4E
0.1 - 6.0	Direct Quadrature	30 / 40	DC - 700	-160	+5V @ 170 mA	LP4	EAR99	HMC1097LP4E
0.25 - 3.8	Direct Quadrature	14 / 38	DC - 250	-158	+3.3V @ 108 mA	LP3	EAR99	HMC495LP3E
0.45 - 4.0	Direct Quadrature	22 / 43	DC - 700	-165	+5V @ 168 mA	LP4	EAR99	HMC697LP4E
4 - 7	Direct Quadrature	17 / 34	DC - 250	-157	+3V @ 93 mA	LP3	EAR99	HMC496LP3E

MODULATORS - Vector Modulators

Frequency (GHz)	Function	Gain Range (dB)	Continuous Phase Control (deg)	IP3 / Noise Floor (Ratio)	IIP3 @ Max. Gain (dBm)	Package	ECCN Code	Part Number
0.7 - 1.0	Vector	-50 to -10	360	186.5	34	LP3	EAR99	HMC630LP3E

MODULATORS - Vector Modulators

Frequency (GHz)	Function	Gain Range (dB)	Continuous Phase Control (deg)	IP3 / Noise Floor (Ratio)	IIP3 @ Max. Gain (dBm)	Package	ECCN Code	Part Number
1.8 - 2.7	Vector	-50 to -10	360	186	35	LP3	EAR99	HMC631LP3E
1.8 - 2.2	Vector	-50 to -10	360	185	33	LP3	EAR99	HMC500LP3E

PASSIVES - Fixed Attenuators

Frequency (GHz)	Function	Attenuation Accuracy (dB)	Nominal Attenuation (dB)	Maximum Input Power (dBm)	Chip Size (Mils)	Package	ECCN Code	Part Number
DC - 50	Thru Line	±0.2	0.15	-	17 x 18	Chip	EAR99	HMC650
DC - 50	Thru Line	±0.3	0.15	-	23 x 18	Chip	EAR99	HMC651
DC - 50	Passive	±0.2	2	27	17 x 18	Chip	EAR99	HMC652
DC - 25	Passive	±0.5	2	27	-	LP2	EAR99	HMC652LP2E
DC - 50	Passive	±0.2	3	26	17 x 18	Chip	EAR99	HMC653
DC - 25	Passive	±0.5	3	26	-	LP2	EAR99	HMC653LP2E
DC - 50	Passive	±0.2	4	25	17 x 18	Chip	EAR99	HMC654
DC - 25	Passive	±0.5	4	25	-	LP2	EAR99	HMC654LP2E
DC - 50	Passive	±0.2	6	26	17 x 18	Chip	EAR99	HMC655
DC - 25	Passive	±0.5	6	26	-	LP2	EAR99	HMC655LP2E
DC - 50	Passive	±0.1	10	25	17 x 18	Chip	EAR99	HMC656
DC - 25	Passive	±1.5	10	25	N/A	LP2	EAR99	HMC656LP2E
DC - 50	Passive	±0.4	15	25	17 x 18	Chip	EAR99	HMC657
DC - 25	Passive	±2	15	25	N/A	LP2	EAR99	HMC657LP2E
DC - 50	Passive	±0.5	20	25	23 x 18	Chip	EAR99	HMC658
DC - 25	Passive	±2	20	25	N/A	LP2	EAR99	HMC658LP2E

PHASE SHIFTERS - Analog

Frequency (GHz)	Function	Insertion Loss (dB)	Phase Range (deg)	2nd Harmonic Pin = -10 dBm (dBc)	Control Voltage Range (Vdc)	Package	ECCN Code	Part Number
1 - 2	Analog	3.5	400°	-40	0 to +13V	LP5	EAR99	HMC934LP5E
2 - 4	Analog	3.5	480° @ 2 GHz 450° @ 4 GHz	-40	0V to +13V	LP5	EAR99	HMC928LP5E
2 - 20	Analog	4	270° @ 2 GHz 180° @ 20 GHz	-45	0.5 to +11V	LP5	EAR99	HMC935LP5E
4 - 8	Analog	4	450° @ 4 GHz 430° @ 8 GHz	-40	0V to +13V	LP4	EAR99	HMC929LP4E
5 - 18	Analog	4	500° @ 5 GHz 100° @ 18 GHz	-80	0V to +10V	Chip	EAR99	HMC247
6 - 15	Analog	7	750° @ 6 GHz 500° @ 15 GHz	-40	0V to +5V	LP4	EAR99	HMC538LP4E
8 - 12	Analog	3.5	425° @ 8 GHz 405° @ 12 GHz	-35	0 to +13V	LP4	EAR99	HMC931LP4E
8 - 23	Analog	-	500°	-35	2.7 to 3.9V	LC3	3A001.a.11.b	HMC877LC3
12 - 18	Analog	4	405° @ 12 GHz 385° @ 18 GHz	-40	0 to +13V	LP4	EAR99	HMC932LP4E
18 - 24	Analog	4.5	495° @ 18 GHz 460° @ 24 GHz	-37	0 to +13V	LP4	EAR99	HMC933LP4E

PHASE SHIFTERS - Digital

Frequency (GHz)	Function	Insertion Loss (dB)	Phase Range (deg)	IIP3 (dBm)	Control Input (Vdc)	Package	ECCN Code	Part Number
8 - 12	4-Bit Digital	5	22.5 to 360	40	0 / -3V	Chip	EAR99	HMC543
8 - 12	4-Bit Digital	6.5	22.5 to 360	37	0 / -3V	LC4B	EAR99	HMC543LC4B
15 - 18.5	5-Bit Digital	7	11.25 to 360	40	0 / -3	Chip	EAR99	HMC644
15 - 18.5	5-Bit Digital	7	11.25 to 360	40	0 / -3	LC5	EAR99	HMC644LC5
1.2 - 1.4	6-Bit Digital	4	5.625 to 360	45	0 / +5V	LP6	EAR99	HMC936LP6E
2.5 - 3.1	6-Bit Digital	4	5.625 to 360	54	0 / +5	Chip	EAR99	HMC647
2.5 - 3.1	6-Bit Digital	4	5.625 to 360	54	0 / +5	LP6	EAR99	HMC647LP6E
2.9 - 3.9	6-Bit Digital	4	5.625 to 360	45	0 / +5	Chip	EAR99	HMC648
2.9 - 3.9	6-Bit Digital	5	5.625 to 360	45	0 / +5	LP6	EAR99	HMC648LP6E
3 - 6	6-Bit Digital	6.5	5.625 to 360	44	0 / +5	Chip	EAR99	HMC649
3 - 6	6-Bit Digital	8	5.625 to 360	44	0 / +5	LP6	EAR99	HMC649LP6E
9 - 12	6-Bit Digital	6.5	5.625 to 360	38	0 / -3	Chip	EAR99	HMC643
9 - 12	6-Bit Digital	7	5.625 to 360	38	0 / -3	LC5	EAR99	HMC643LC5
9 - 12.5	6-Bit Digital	6.5	5.625 to 360	41	0 / +5	Chip	EAR99	HMC642
9 - 12.5	6-Bit Digital	7	5.625 to 360	41	0 / +5	LC5	EAR99	HMC642LC5

SMT & Chip (Die) Products

POWER DETECTORS - Log Detector/Controllers & RMS Detectors

Frequency (GHz)	Function	Dynamic Range (dB)	RSSI Slope (mV/dB)	RF Threshold Level (dBm)	Bias Supply	Package	ECCN Code	Part Number
50 Hz - 3.0	Log Detector / Controller	74 ±3	19	-66	+3.3V @ 29 mA	LP4	EAR99	HMC612LP4E
0.001 - 8.0	Log Detector / Controller	70 ±3	-25	-61	+5V @ 113 mA	LP4	EAR99	HMC602LP4E
0.001 - 10.0	Log Detector / Controller	73 ±3	-25	-65	+5V @ 103 mA	Chip	EAR99	HMC611
0.001 - 10.0	Log Detector / Controller	70 ±3	-25	-65	+5V @ 106 mA	LP4	EAR99	HMC611LP4E
0.01 - 4.0	Log Detector / Controller	70 ±3	19	-68	+3.3V @ 30 mA	LP4	EAR99	HMC601LP4E
0.05 - 4.0	Log Detector / Controller	70 ±3	19	-69	+3.3V @ 29 mA	LP4	EAR99	HMC600LP4E
0.05 - 8.0	Log Detector / Controller	54 ±1	17.5	-55	+5V @ 17 mA	LP3	EAR99	HMC713LP3E
0.1 - 2.7	Log Detector / Controller	54 ±1	17.5	-52	+5V @ 17 mA	MS8	EAR99	HMC713MS8E
8 - 30	Log Detector	54 ±3	13.3	-55	+3.3V @ 88 mA	LP3	EAR99	HMC662LP3E
1 - 23	mmW Power Detector	56 ±3	14.2	-52	+3.3V @ 91 mA	LP3	EAR99	HMC948LP3E
DC - 3.9	RMS Power Detector	60 ±1	37	-69	+5V @ 50 mA	LP4	EAR99	HMC1010LP4E
DC - 3.9	RMS, Single-Ended	72 ±1	35	-68	+5V @ 55 mA	LP4	EAR99	HMC1020LP4E
DC - 3.9	RMS, Single-Ended with Envelope Tracker	70 ±1	35	-68	+5V @ 75 mA	LP4	EAR99	HMC1021LP4E
DC - 3.9	Dual RMS, Single-Ended	70 ±1	38.5	-66	+5V @ 143 mA	LP5	EAR99	HMC1030LP5E
DC - 5.8	RMS Power Detector	40 ±1	37	-69	+5V @ 42 mA	LP4	EAR99	HMC909LP4E

SDLVAs - Successive Detection Log Video Amplifiers

Frequency (GHz)	Function	Dynamic Range (dB)	RSSI Slope (mV/dB)	RF Threshold Level (dBm)	Bias Supply	Package	ECCN Code	Part Number
0.1 - 20	SDLVA	59	14	-54	+3.3V @ 83 mA	LC4B	EAR99	HMC613LC4B
0.5 - 18.5	SDLVA, Extended Range	67	15	-62	+3.3V @ 183 mA	LP4	EAR99	HMC1013LP4E
0.6 - 20	SDLVA	59	14	-54	+3.3V @ 80 mA	Chip	EAR99	HMC913
0.6 - 20	SDLVA	59	14	-54	+3.3V @ 80 mA	LC4B	EAR99	HMC913LC4B
1 - 20	SDLVA with Limited RF Output	55	15	-53	+3.3V @ 153 mA	LC4B	EAR99	HMC813LC4B
1 - 26	SDLVA with Limited RF Output	55	14.5	-53	+3.3V @ 150 mA	Chip	EAR99	HMC813

SWITCHES

Frequency (GHz)	Function	Insertion Loss (dB)	Isolation (dB)	Input P1dB (dBm)	Control Input (Vdc)	Package	ECCN Code	Part Number
SPST & SPDT Switches								
DC - 3.5	SPST, Non-Reflective	0.6	40	32	0 / +3V	LP2C	EAR99	HMC1055LP2CE
DC - 6	SPST, Failsafe	0.7	25	27	0 / +2.2 to +5V	SOT26	EAR99	HMC550E
DC - 6	SPST, High Isolation	1.4	52	27	0 / -5V	G7 Hermetic	EAR99	HMC231G7
DC - 2.5	SPDT, Reflective	0.4	36	29	0 / -5V	S8	EAR99	HMC239AS8E
DC - 3	SPDT, Reflective	0.4	27	30	0 / +3V	MS8	EAR99	HMC190AMS8E
DC - 3	SPDT, High Isolation	0.7	50	23	0 / +5V	MS8	EAR99	HMC194MS8E
DC - 3	SPDT, Reflective	0.4	28	30	0 / +3V	SOT26	EAR99	HMC197AE
DC - 3	SPDT, Reflective	0.4	28	30	0 / +3V	SOT26	EAR99	HMC221AE
DC - 3	SPDT, Reflective	0.3	31	34	0 / +3 to +8V	SOT26	EAR99	HMC545E
DC - 3.5	SPST, Non-Reflective	0.5	45	25	0 / +5V	AMS8G	EAR99	HMC284AMS8GE
DC - 3.5	SPST, Non-Reflective	0.6	40	32	0 / +3V	LP2C	EAR99	HMC1055LP2CE
DC - 4	SPDT, Reflective	0.5	28	29	0 / -5V or +5V / 0	Chip	EAR99	HMC240A
DC - 4	SPDT, High Isolation	0.9	65	31	0 / +5V	LP4C	EAR99	HMC349LP4CE
DC - 4	SPDT, High Isolation	0.9	57	31	0 / +5V	MS8G	EAR99	HMC349MS8GE
DC - 4	SPDT, High Isolation	1.1	47	31	0 / +5V	MS8G	EAR99	HMC435MS8GE
DC - 4	SPDT, Differential	0.8	45	35	0 / +3V to	LP4	EAR99	HMC922LP4E
DC - 6	SPDT, High Isolation	1.4	50	26	0 / -5V	G7 Hermetic	EAR99	HMC232G7
DC - 6	SPDT, High Isolation	1.4	43	26	0 / -5V	G8 Hermetic	EAR99	HMC232G8
DC - 6	SPDT, High Isolation	1.4	43	26	0 / -5V	G8 Hermetic	EAR99	HMC233G8
DC - 6	SPDT, High Isolation	1.6	42	25	0 / +5V	MS8G	EAR99	HMC336MS8GE
DC - 6	SPDT, High Isolation	1.4	46	27	0 / -5V	G7 Hermetic	EAR99	HMC607G7
DC - 6	SPDT, High Isolation	0.8	60	35	0 / +3 to +5V	LP4C	EAR99	HMC849LP4CE
DC - 8	SPDT, High Isolation	1.4	50	26	0 / -5V	C8	EAR99	HMC232C8
DC - 8	SPDT, High Isolation	1.5	45	26	0 / -5V	C8	EAR99	HMC234C8
DC - 8	SPDT, High Isolation	1.2	48	23	0 / -5V	MS8G	EAR99	HMC270MS8GE
DC - 8	SPDT, High Isolation	2.0	44	23	0 / -5V	C8	EAR99	HMC347C8
DC - 8	SPDT, High Isolation	2.2	35	23	0 / -5V	G8 Hermetic	EAR99	HMC347G8
DC - 12	SPDT, High Isolation	1.5	55	27	0 / -5V	LP4	EAR99	HMC232LP4E
DC - 14	SPDT, High Isolation	1.7	44	23	0 / -5V	LP3	EAR99	HMC347LP3E
DC - 15	SPDT, High Isolation	1.4	50	26	0 / -5V	Chip	EAR99	HMC232
DC - 15	SPDT, High Isolation	1.7	60	26	0 / -5V	Chip	EAR99	HMC607
DC - 20	SPDT, High Isolation	1.7	45	23	0 / -5V	Chip	EAR99	HMC347
DC - 20	SPDT, High Isolation	1.8	47	23	0 / -5V	LP3	EAR99	HMC547LP3E

SWITCHES

Frequency (GHz)	Function	Insertion Loss (dB)	Isolation (dB)	Input P1dB (dBm)	Control Input (Vdc)	Package	ECCN Code	Part Number
DC - 28	SPDT, High Isolation	1.8	47	23	0 / -5V	LC3	EAR99	HMC547LC3
0.1 - 50	SPDT, Reflective	1.9	31	25	0 / -3V	Chip	EAR99	HMC986
55 - 86	SPDT, PIN MMIC	2	30	-	-5 / +5	Chip	5A991.h	HMC-SDD112
0.1 - 2.1	SPDT, 40W, Failsafe	0.4	22	46	0 / +3V to +8V	LP2	EAR99	HMC646LP2E
0.2 - 2.2	SPDT, 10W, Failsafe	0.4	40	> 40	0 / +3 to +8V	MS8G	EAR99	HMC546MS8GE
0.2 - 2.7	SPDT, 10W, Failsafe	0.4	35	43	0 / +3 to +8V	LP2	EAR99	HMC546LP2E
0.824 - 0.894	SPDT, 10W, T/R	0.6	22	> 40	0 / +5V	SOT26	EAR99	HMC446E
DC - 2.5	SPDT, CATV	0.6	58	28	0 / +5V	LP3	EAR99	HMC348LP3E
DC - 3	SPDT T/R	0.5	25	39	0 / +3V to +8V	MS8	EAR99	HMC174MS8E
DC - 3	SPDT, 5W, T/R	0.3	30	39	0 / +3 to +10V	MS8	EAR99	HMC574MS8E
DC - 3	SPDT, 3W, T/R	0.3	30	37	0 / +3 to +10V	SOT26	EAR99	HMC595E
DC - 4	SPDT T/R	0.25	23	39	0 / +3 to +5V	SOT26	EAR99	HMC544E
DC - 4	SPDT, 10W, T/R	0.4	30	40	0 / +3 to +8V	MS8G	EAR99	HMC784MS8GE
DC - 6	SPDT T/R	0.5	27	37	0 / +3 to +5V	MS8G	EAR99	HMC536MS8GE
DC - 6	SPDT T/R	0.6	27	37	0 / +3 to +5V	LP2	EAR99	HMC536LP2E

Multi-Throw Switches

DC - 3.5	SP3T	0.5	44	26	TTL/CMOS	QS16	EAR99	HMC245QS16E
DC - 2	SP4T	0.8	32	24	0 / -5V	S14	EAR99	HMC182S14E
DC - 3.5	SP4T	0.5	45	25	TTL/CMOS	QS16	EAR99	HMC241QS16E
DC - 4	SP4T	0.6	47	26	TTL/CMOS	LP3	EAR99	HMC241LP3E
DC - 4	SP4T	0.7	40	25	TTL/CMOS	G16 Hermetic	EAR99	HMC244G16
DC - 8	SP4T	1.8	42	21	0 / -5V	Chip	EAR99	HMC344
DC - 8	SP4T	2.0	45	26	0 / -5V	LC3	EAR99	HMC344LC3
DC - 8	SP4T	1.8	40	21	0 / -5V	LP3	EAR99	HMC344LP3E
DC - 8	SP4T	2.2	32	21	0 / 5V	LP3	EAR99	HMC345LP3E
DC - 12	SP4T	1.8	42	27	0 / -5V	LH5 Hermetic	EAR99	HMC344LH5
DC - 18	SP4T	2.1	42	24	0 / -5V	Chip	EAR99	HMC641
DC - 20	SP4T	2.1	42	23	0 / -5V	LC4	EAR99	HMC641LC4
DC - 20	SP4T	2.3	45	22	0 / -5V	LP4	EAR99	HMC641LP4E
23 - 30	SP4T	2.8	35	25	0 / -3V	LC4	EAR99	HMC944LC4
NEW! 23 - 30	SP4T	2.8	26	-	0 / -3V	LC4	EAR99	HMC1084LC4
DC - 3	SP6T	0.8	41	24	TTL/CMOS	QS24	EAR99	HMC252QS24E
DC - 2	SP8T	1.3	30	20	0 / -5V	QS24	EAR99	HMC183QS24E
DC - 2.5	SP8T	1.1	36	23	TTL/CMOS	QS24	EAR99	HMC253QS24E
DC - 3.5	SP8T	1.2	36	24	TTL/CMOS	LC4	EAR99	HMC253LC4
DC - 8	SP8T	2.3	40	23	0 / 5V	LP4	EAR99	HMC321LP4E
DC - 8	SP8T	2.5	25	23	0 / -5V	LP4	EAR99	HMC322LP4E
DC - 10	SP8T	2	38	23	0 / -5V	Chip	EAR99	HMC322

Bypass, Diversity, Matrix & Transfer Switches

DC - 2.5	Bypass DPDT	0.3	25	23	0 / +5V	MS8	EAR99	HMC199MS8E
5 - 6	DPDT, Diversity	1.2	20	30	0 / +5V	MS8G	EAR99	HMC393MS8GE
0.2 - 3.0	4x2 Matrix	6	44	26	0 / +5V	LP4	EAR99	HMC276LP4E
0.2 - 3.0	4x2 Matrix	6.5	43	22	0 / +3 to +5V	LP4	EAR99	HMC596LP4E
0.7 - 3.0	4x2 Matrix	5.8	33	26	0 / +5V	QS24	EAR99	HMC276QS24E
DC - 8	Transfer	1.2	42	26	0 / +5V	LP3	EAR99	HMC427LP3E

TRANSCEIVERS

Tx / Rx mmWave ICs

Frequency (GHz)	Function	P1dB (dBm) NF (dB)	Max Gain (dB)	Gain Adjust (dB)	Phase Noise @ 1 MHz Offset (dBc/Hz)	Power Dissipation (W)	Package	ECCN Code	Part Number
57 - 64	60 GHz Integrated Transmitter	12 dBm	38	17	-86	0.8	Chip	5A991.b	HMC6000
57 - 64	60 GHz Integrated Receiver	6 dB	67	65	-86	0.61	Chip	5A991.b	HMC6001

Tx / Rx mmWave ICs (w/ Antenna-in-Package)

Frequency (GHz)	Function	Antenna Gain (dBi)	P1dB (dBm)	NF (dB)	Max Gain (dB)	Gain Adjust (dB)	Phase Noise @ 1 MHz (dBc/Hz)	Package	ECCN Code	Part Number
57 - 64	60 GHz Tx w/ Integrated Antenna	7.5	11	-	38	17	-86	LP711	5A991.b	HMC6000LP711E
57 - 64	60 GHz Rx w/ Integrated Antenna	7.5	-	7	67	65	-86	LP711	5A991.b	HMC6001LP711E

Rx RFICs

Frequency (GHz)	Function	Input IP3 (dBm)	NF (dB)	Conv. Gain (dB)	PLL FOM (dBc/Hz) (Int./Frac.)	Package	ECCN Code	Part Number
0.7 - 3.5	Wideband Dual-Downconverter w/ Frac-N PLL/VCO	+24	9	8	-230 / -227	LP6G	5A991.b	HMC1190LP6GE

Tx RFICs

Frequency (GHz)	Function	Output IP3 (dBm)	Output P1dB (dBm)	Output Noise Floor (dBc/Hz)	PLL FOM (dBc/Hz) (Int./Frac.)	Package	ECCN Code	Part Number
0.4 - 4	Wideband Direct Modulator w/ Frac-N PLL/VCO	+30	+11	-160	-230 / -227	LP7F	5A991.b	HMC1197LP7FE

VARIABLE GAIN AMPLIFIERS

Frequency (GHz)	Function	Gain Control Range (dB)	NF * (dB)	OIP3 * (dBm)	P1dB (dBm)	Bias Supply	Package	ECCN Code	Part Number
0.5 - 6.0	Analog	-35 to 15	7.5	28	21	+5V @ 90 mA	LP5	EAR99	HMC972LP5E
2.3 - 2.5	Analog	-8 to 22	2.5	7	3	+3V @ 9 mA	MS8	EAR99	HMC287MS8E
5 - 12	Analog	22	2	34	23	+5V @ 120 mA	LP4	EAR99	HMC996LP4E
6 - 17	Analog	0 to 23	5	30	22	+5V @ 170 mA	Chip	EAR99	HMC694
6 - 17	Analog	0 to 23	6	30	22	+5V @ 175 mA	LP4	EAR99	HMC694LP4E
17 - 27	Analog	15	3.5	30	24	+5V @ 170 mA	LC4	EAR99	HMC997LC4
0.03 - 0.4	5-Bit digital, Differential Outputs	-4 to 19	5	40	25	+5V @ 240 mA	LP4	EAR99	HMC680LP4E
0.05 - 0.8	5-Bit Digital	-8 to 15	5	35	18	+5V @ 65 mA	LP4	EAR99	HMC628LP4E
0.07 - 4.0	6-Bit Digital, Serial & Parallel Control	-19.5 to 12	4	39	23	+5V @ 150 mA	LP5	EAR99	HMC742LP5E
0.5 - 4.0	6-Bit Digital, Serial & Parallel Control or Latched Parallel Control	-19 to 12.5	4	39	21.5	+5V @ 150 mA	LP5	EAR99	HMC742HFLP5E
0.7 - 1.2	6-Bit Digital, Serial & Parallel Control	-2.5 to 29	0.8	38.5	21	+5V @ 236 mA	LP5	EAR99	HMC707LP5E
0.7 - 2.7	6-Bit Digital	6.5 to 38	4.4	45	25	+5V @ 218 mA	LP5	EAR99	HMC926LP5E
DC - 1	6-Bit Digital, Serial & Parallel Control	-11.5 to 20	4.3	36	20	+5V @ 90 mA	LP5	EAR99	HMC627LP5E
DC - 1	6-Bit Digital, Parallel Control	8.5 to 40	2.8	36	20	+5V @ 176 mA	LP5	EAR99	HMC626LP5E
DC - 1	6-Bit Digital, Serial Control	13.5 to 45	2.7	36	20	+5V @ 176 mA	LP5	EAR99	HMC681LP5E
DC - 6	6-Bit Digital, Serial & Parallel Control	-13.5 to 18	6	33	19	+5V @ 88 mA	LP5	EAR99	HMC625LP5E
0.5 - 6.0	6-Bit Digital, Serial & Parallel Control	-13.5 to 18	6	33	19	+5V @ 88 mA	LP5	EAR99	HMC625HFLP5E
1.7 - 2.2	6-Bit Digital, Serial & Parallel Control	-2.5 to 29	1.0	37.5	21.5	+5V @ 252 mA	LP5	EAR99	HMC708LP5E
DC - 4	Dual 6-Bit Digital, Serial Control	-45 to 18	6	33	18	+5V @ 82 mA	LP6C	EAR99	HMC743LP6CE

* Maximum Gain State

MARKET & APPLICATION GUIDE

Automotive: Telematics & Sensors, 2 - 110 GHz and Broadband, DC - 11 GHz

24 GHz FMCW AUTOMOTIVE SENSOR

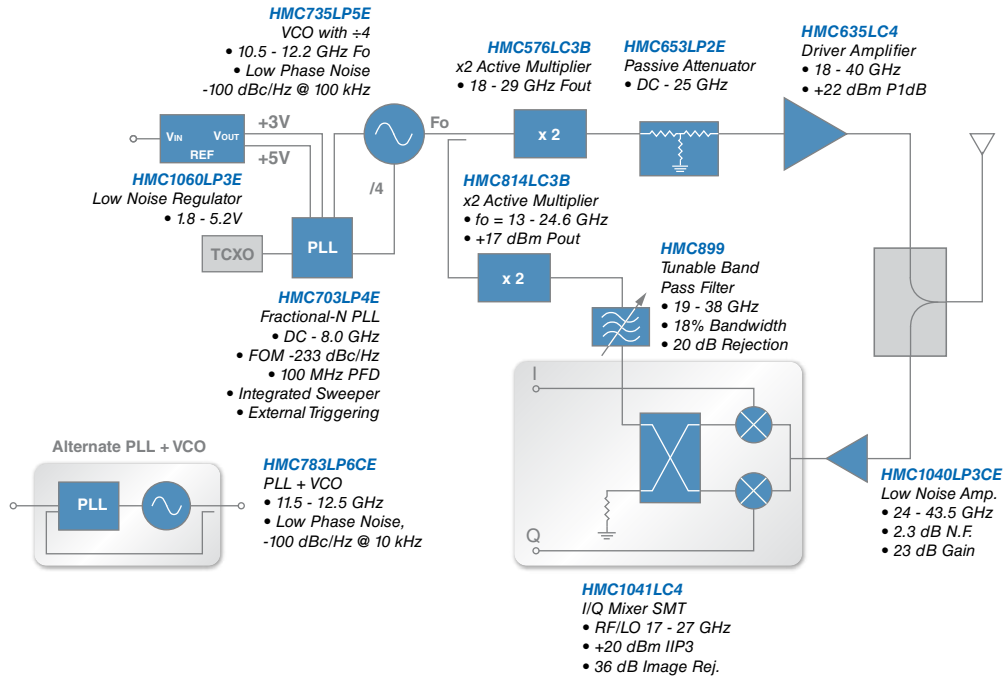

Typical Automotive application is illustrated. See the full product listing for alternatives to the HMC products shown in each functional block.

CABLE MODEM, CATV, DBS & VoIP SOLUTIONS, 5 - 2150 MHz

Cable Modem Termination System (CMTS)

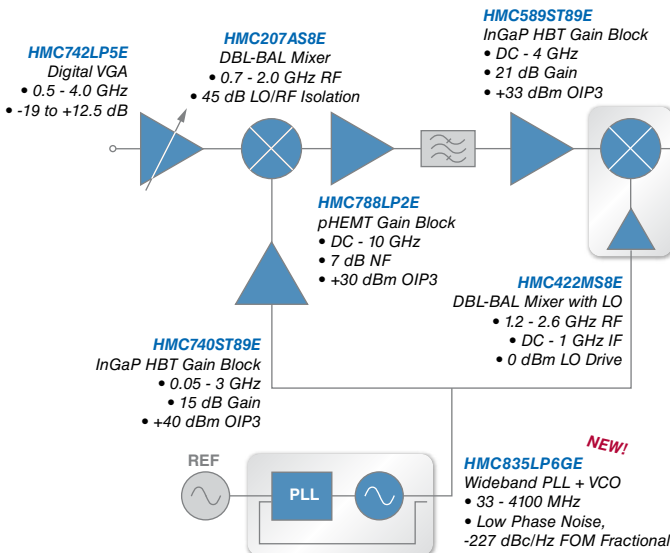

A Selection of SPNT Switches for CATV Filter & Signal Routing

Part Number	Frequency (GHz)	Function	1 GHz Loss / Isolation (dB)
HMC348LP3E	DC - 2.5	SPDT, 75 Ω	0.6 / 58
HMC349LP4CE	DC - 4	SPDT	0.9 / 65
HMC347LP3E	DC - 14	SPDT	1.7 / 44
HMC245QS16E	DC - 3.5	SP3T	0.5 / 44
HMC345LP3E	DC - 8	SP4T	2.2 / 32
HMC252QS24E	DC - 3	SP6T	2.0 / >45
HMC321LP4E	DC - 8	SP8T	2.0 / >45

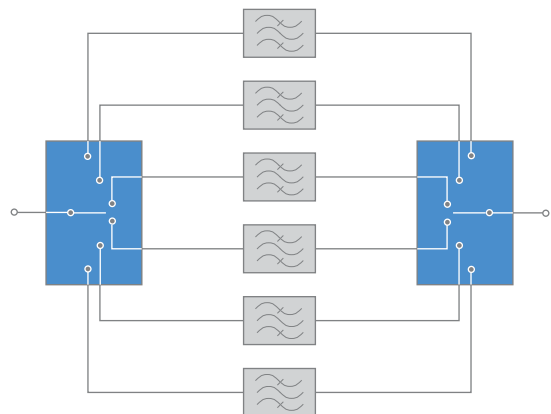

Typical Broadband applications are illustrated. See the full product listing for alternatives to the select HMC products shown in each functional block.

Broadband, DC - 11 GHz and Cellular Infrastructure, 380 - 2690 MHz

WiMAX & FIXED WIRELESS, 2 - 6 GHz

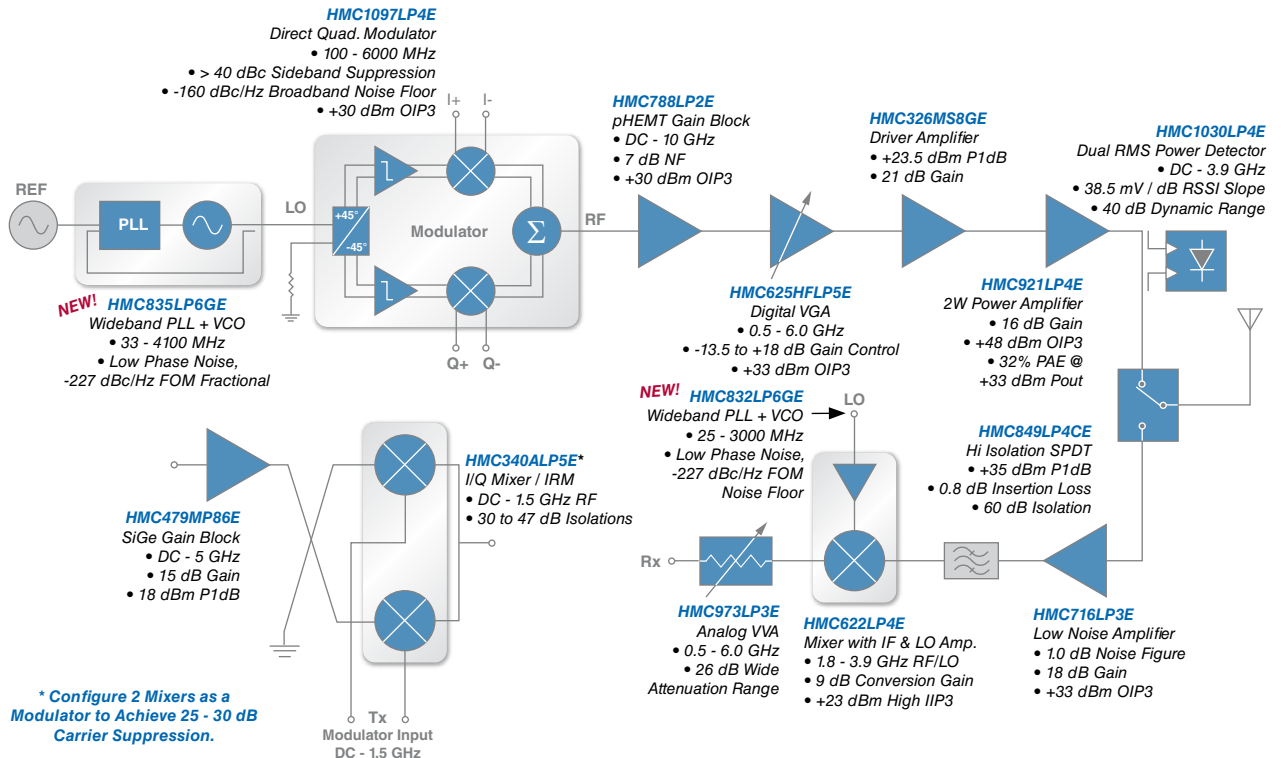

Typical WiMAX / FWA Transceiver is illustrated. See the full product listing for alternatives to the select HMC products shown in each functional block.

CDMA/GSM/TD-SCDMA REPEATER SOLUTIONS

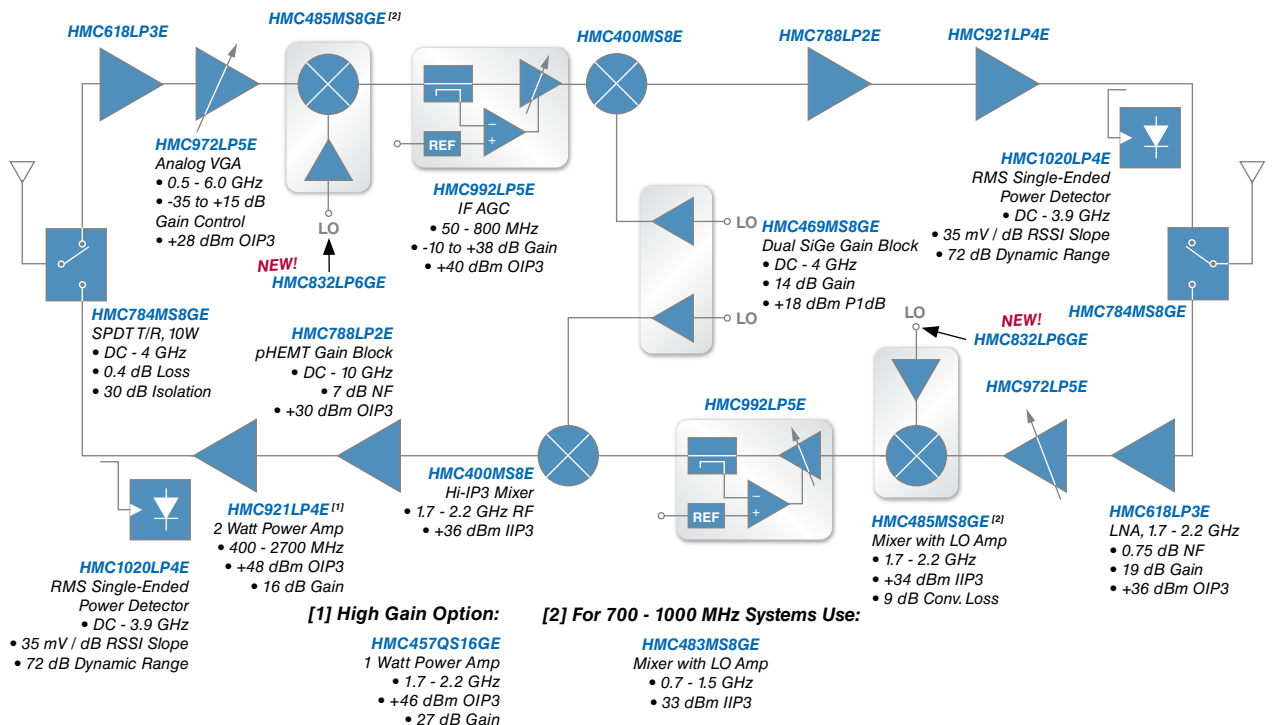

Typical Cellular/PCS/3G applications are illustrated.

See the full product listing for alternatives to the select HMC products shown in each functional block.

MARKET & APPLICATION GUIDE

Cellular Infrastructure, 380 - 2690 MHz

WiMAX / LTE / 4G TRANSMITTER SOLUTIONS

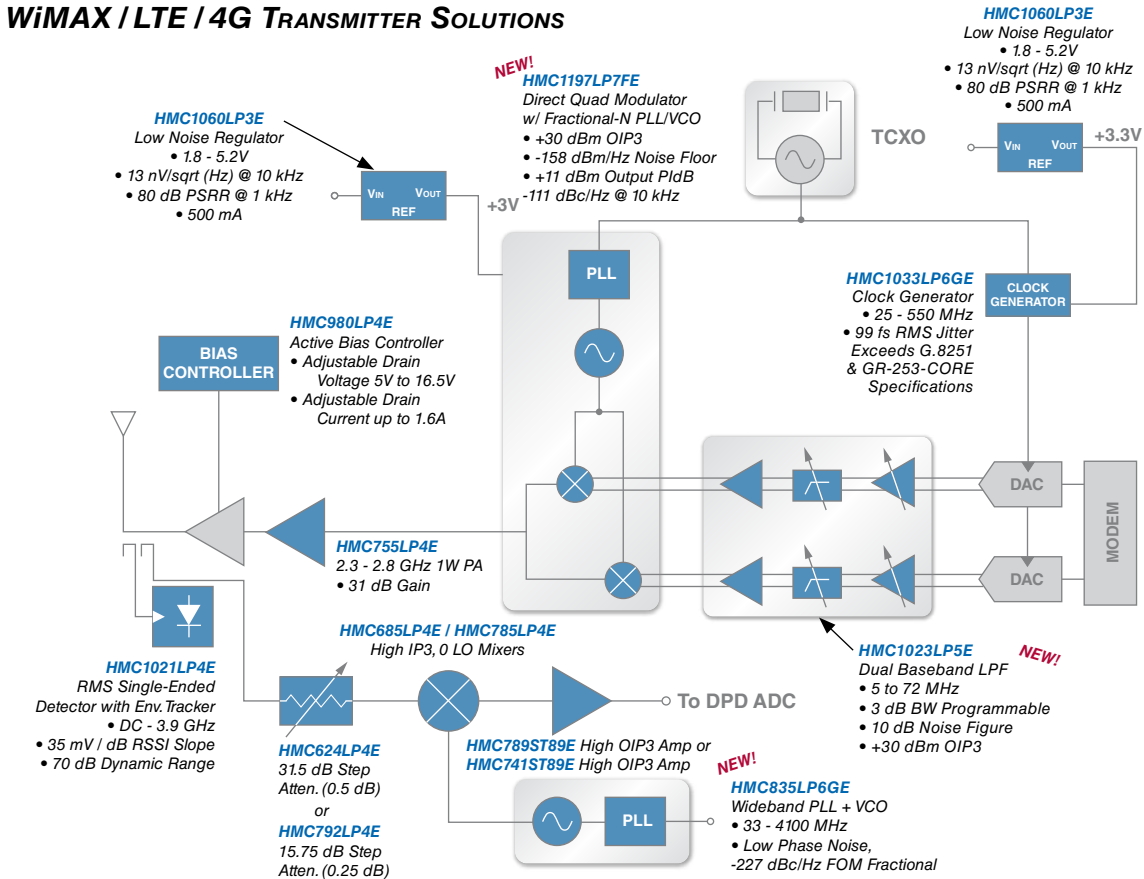

WiMAX / LTE / 4G RECEIVER SOLUTIONS FEATURING HETERODYNE DOWNCONVERSION

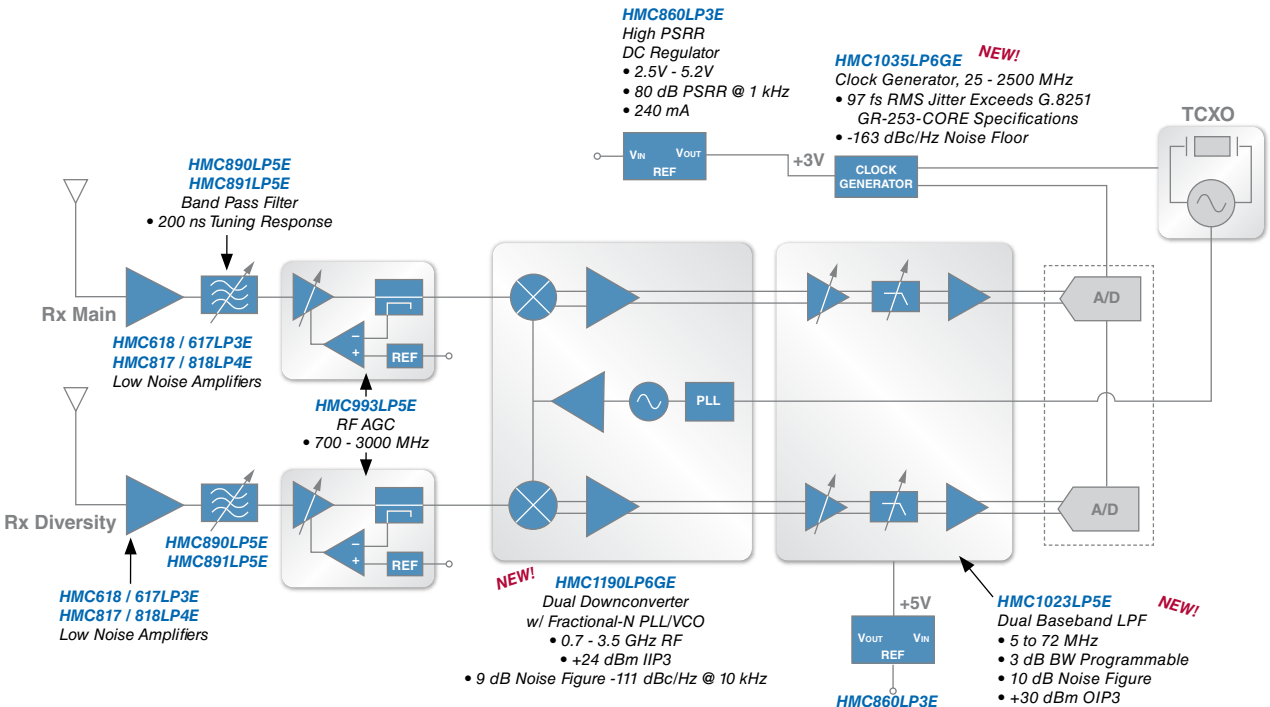

Typical WiMAX/LTE/4G applications are illustrated. See the full product listing for alternatives to the select HMC products shown in each functional block.

Microwave & mmWave Communications, Test & Measurement & Sensors, 2 - 86 GHz

DOUBLE UPCONVERSION & DIRECT DOWNCONVERSION

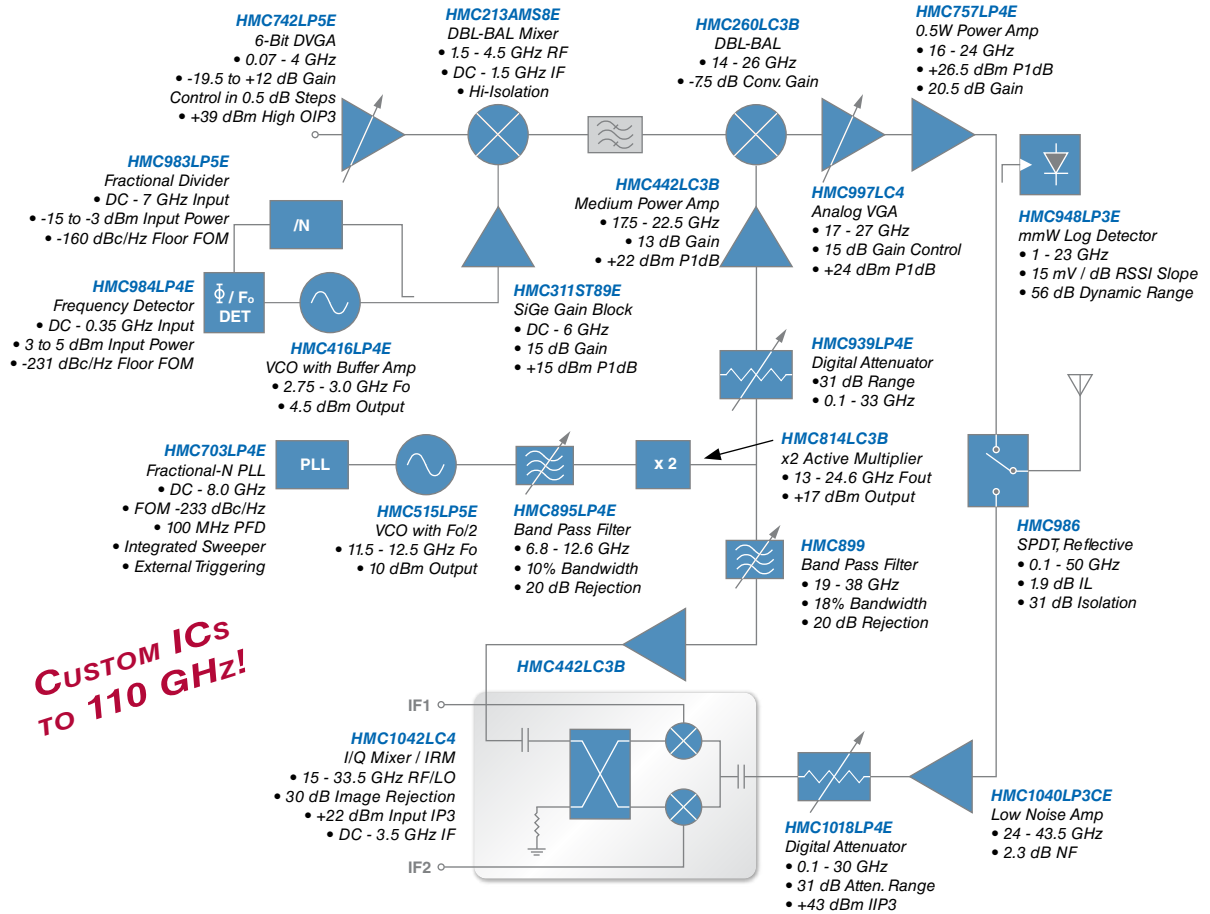

HITTITE'S HIGH FREQUENCY LO SOURCE ALTERNATIVES

PLL & VCO CHIPSET

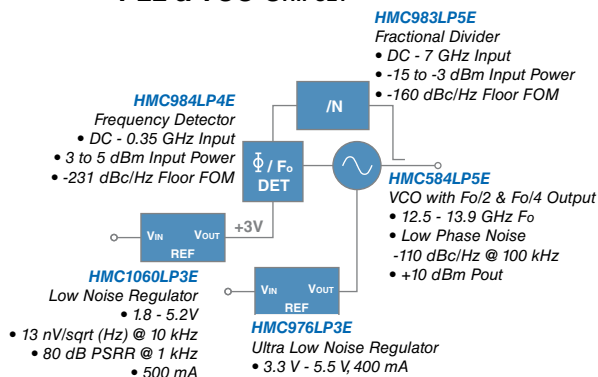

PLL WITH INTEGRATED VCO IC

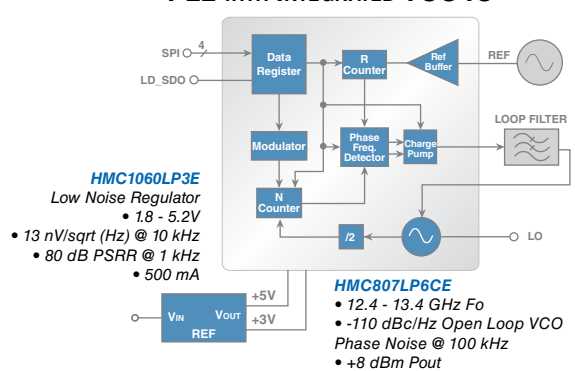

Typical Microwave / Millimeterwave application is illustrated.
See the full product listing for alternatives to the select HMC products shown in each functional block.

MARKET & APPLICATION GUIDE

Microwave & mmWave Communications, Test & Measurement & Sensors, 2 - 86 GHz

CHIPSETS FOR 6 TO 42 GHz MICROWAVE RADIO BACKHAUL

Features

- ◆ Integrated IQ Tx Upconverter IC with a X2 LO Buffer & a High Linearity Driver Amplifier
- ◆ High Linearity 17 - 24 GHz Power Amplifier with 40 dBm OIP3 & 32 dBm Saturated Power
- ◆ Low Noise Image Rejection Downconverter IC with a X2 Integrated LO Buffer
- ◆ Very Low Phase Noise PLL IC with an Integrated VCO

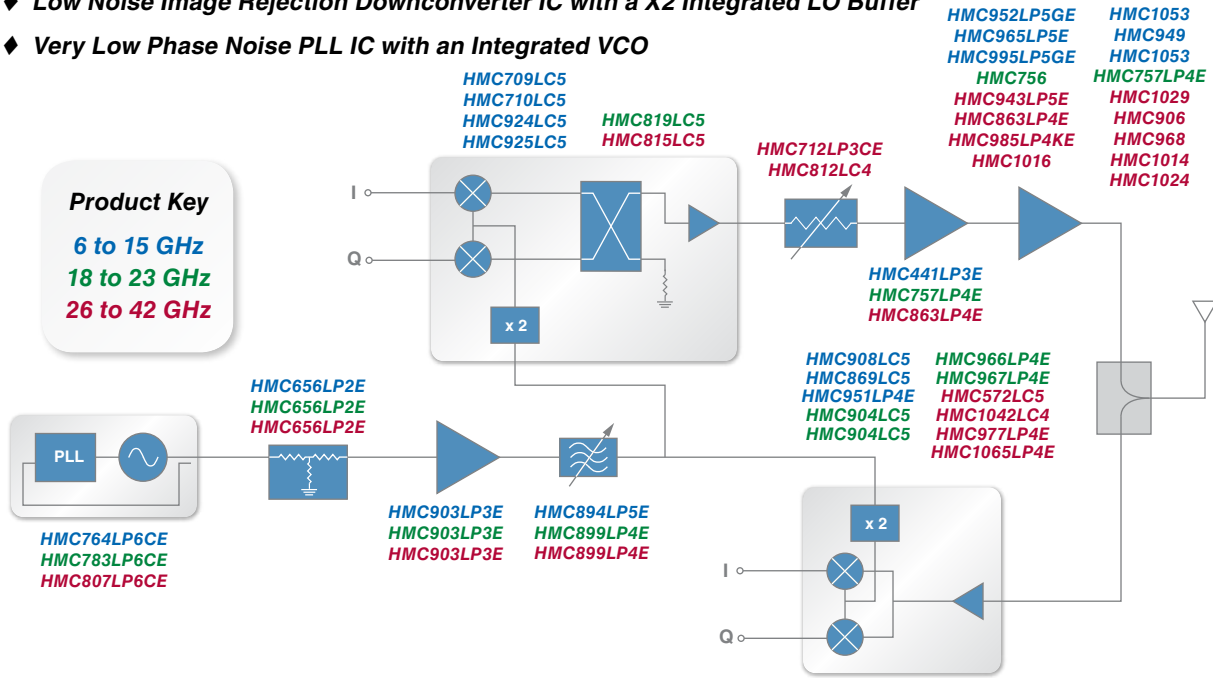

70 / 80 GHz CHIPSET FOR E-BAND BACKHAUL RADIO

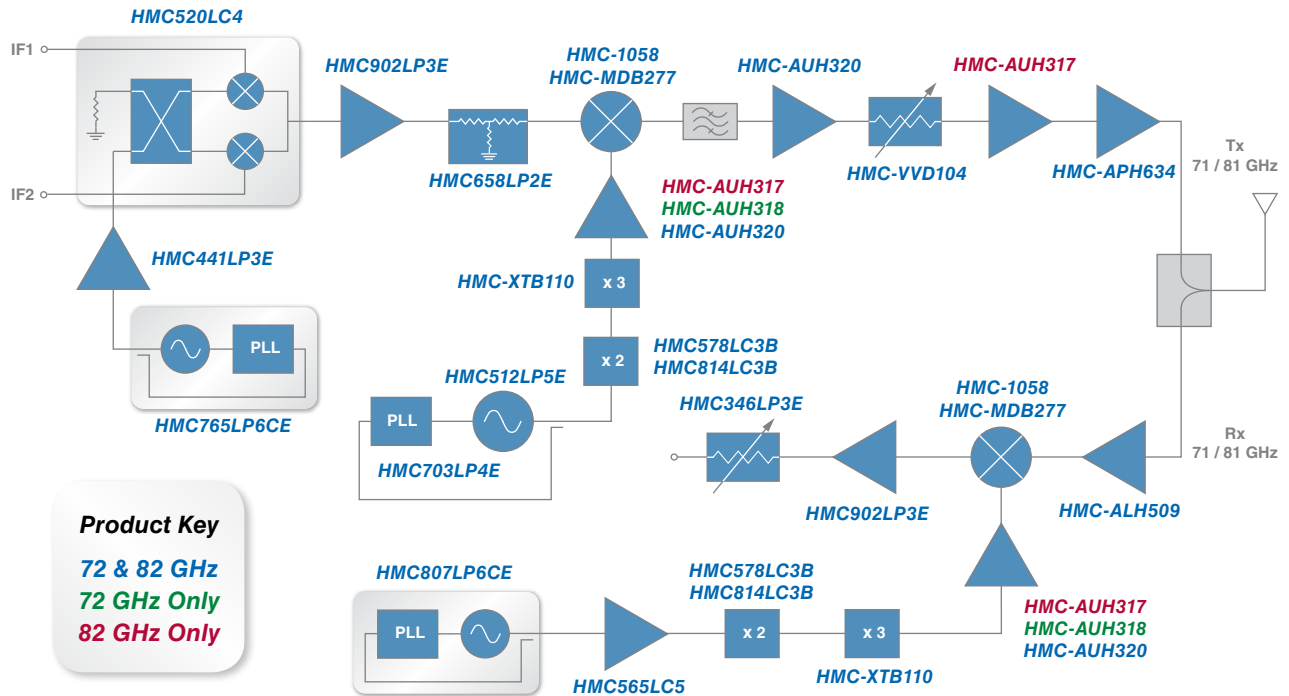

Typical Microwave / Millimeterwave application is illustrated. See the full product listing for alternatives to the select HMC products shown in each functional block.